

TAR

TENNESSEE ADMINISTRATIVE REGISTER



June 15, 2005
Volume 31, Number 6

RILEY C. DARNELL
Secretary of State

Division of Publications
8th Floor, Tennessee Tower
312 8th Avenue North
Nashville TN 37243 - 0310

DEPARTMENT OF STATE NONDISCRIMINATION POLICY STATEMENT

Pursuant to its policy of nondiscrimination, the Department of State does not discriminate on the basis of race, sex, religion, color, national or ethnic origin, age, disability, or military service in its policies, or in the admission or access to, or treatment or employment in, its programs, services, or activities.

Equal Employment Opportunity/Affirmative Action inquiries or complaints should be directed to the Department of State, Bard G. Fisher, EEO/AA Coordinator, 7th Floor, Snodgrass-Tennessee Tower, 312 Eighth Avenue North, Nashville, TN, 37243-0311 or call (615) 741-7411, Tennessee Relay Center TDD 1-800-848-0298, Voice 1-800-848-0299. ADA inquiries or complaints should be directed to Mr. Fisher at the above mentioned location.

PUBLIC INSPECTION OF DOCUMENTS

A certified copy of each document filed with the Department of State, Division of Publications is available for public inspection from 8 A.M. to 4:30 P.M., Monday through Friday. Copies of documents may be made at a cost of 25 cents per page and \$2 for the certification page, payable in advance if requested. The Division of Publications is located on the Eighth Floor, Snodgrass-Tennessee Tower, 312 Eighth Avenue North, Nashville, TN 37243 - 0310. Telephone inquiries may be made by calling (615) 741-0522, Tennessee Relay Center TDD 1-800-848-0298, Voice 1-800-848-0299. Individuals with disabilities who wish to inspect these filings should contact the Division of Publications to discuss any auxiliary aids or services needed to facilitate such inspection. Such contact may be made in person, by writing, telephonically or otherwise and should be made at least ten (10) days in advance of the date such party intends to make such inspection to allow time for the Division of Publications to provide such aid or service.

PREFACE

The Tennessee Administrative Register (T.A.R) is an official publication of the Tennessee Department of State. The *T.A.R.* is compiled and published monthly by the Department of State pursuant to *Tennessee Code Annotated, Title 4, Chapter 5*. The *T.A.R.* contains in their entirety or in summary form the following: (1) various announcements (e.g. the maximum effective rate of interest on home loans as set by the Department of Commerce and Insurance, formula rate of interest and notices of review cycles); (2) emergency rules; (3) proposed rules; (4) public necessity rules; (5) notices of rulemaking hearings and (6) proclamations of the Wildlife Resources Commission.

Emergency Rules are rules promulgated due to an immediate danger to the public health, safety or welfare. These rules are effective immediately on the date of filing and remain in effect thereafter for up to 165 days. Unless the rule is promulgated in some permanent form, it will expire after the 165-day period. The text or a summary of the emergency rule will be published in the next issue of the *T.A.R.* after the rule is filed. Thereafter, a list of emergency rules currently in effect will be published.

Proposed Rules are those rules the agency is promulgating in permanent form in the absence of a rulemaking hearing. Unless a rulemaking hearing is requested within 30 days of the date the proposed rule is published in the *T.A.R.*, the rule will become effective 105 days after said publication date. All rules filed in one month will be published in the *T.A.R.* of the following month.

Public Necessity Rules are promulgated to delay the effective date of another rule that is not yet effective, to satisfy constitutional requirements or court orders, or to avoid loss of federal programs or funds. Upon filing, these rules are effective for a period of 165 days. The text or summary of the public necessity rule will be published in the next issue of the *T.A.R.* Thereafter, a list of public necessity rules currently in effect will be published.

Once a rule becomes effective, it is published in its entirety in the *official compilation-Rules and Regulations of the State of Tennessee*. Replacement pages for the compilation are published on a monthly basis as new rules or changes in existing rules become effective.

Wildlife Proclamations contain seasons, creel, size and bag limits, and areas open to hunting and/or fishing. They also establish wildlife and/or public hunting areas and declare the manner and means of taking. Since Wildlife Proclamations are published in their entirety in the *T.A.R.*, they are not published in the *official compilation-Rules and Regulations of the State of Tennessee*.

Reproduction - There are no restrictions on the reproduction of official documents appearing in the Tennessee Administrative Register.

TABLE OF CONTENTS

ANNOUNCEMENTS

Financial Institutions, Department of Announcement of Formula Rate of Interest	5
Maximum Effective Rate of Interest.....	5
Government Operations Committee Announcement of Public Hearing	6-10
Health Services and Development Agency Notice of Beginning of Review Cycle	11

EMERGENCY RULES

Emergency Rules Now in Effect	12
-------------------------------------	----

PROPOSED RULES

Education, Board of	13-27
Financial Institutions, Department of	28-29
Health, Department of.....	30-32
Labor and Workforce Development, Department of	33-82

PUBLIC NECESSITY RULES

Public Necessity Rules Now in Effect	83
Finance and Administration, Department of.....	84-89
Human Services, Department of.....	90-109

RULEMAKING HEARINGS

Counselors, Marital and Family Therapists, and Clinical Pastoral Therapists, Board for Professional	110
Chiropractic Examiners, Board of	111-112
Dentistry, Board of	113-114
Electrolysis Examiners, Board of	115-117
Environment and Conservation, Department of.....	118-196
Finance and Administration, Department of.....	197-201
Health, Department of.....	202
Human Services, Department of.....	203-208
Medical Examiners, Board of.....	209-212
Nursing, Board of.....	213

WILDLIFE PROCLAMATIONS

05-02	214
05-03	215
05-04	216
05-05	217
05-06	218
05-07	219
05-08	220
05-09	221-226
05-10	227
05-11	228-232
05-12	233-235
05-13	236-243
05-14	244-291
05-15	292-296

CERTIFICATE OF APPROVAL	297
--------------------------------------	------------

ANNOUNCEMENTS

DEPARTMENT OF FINANCIAL INSTITUTIONS – 0180

ANNOUNCEMENT OF FORMULA RATE OF INTEREST

Pursuant to the provisions of Chapter 464, Public Acts of 1983, the Commissioner of Financial Institutions hereby announces that the formula rate of interest is 10.00%.

This announcement is placed in the Tennessee Administrative Register for the purpose of information only and does not constitute a rule within the meaning of the Uniform Administrative Procedures Act.

Kevin P. Lavender

DEPARTMENT OF FINANCIAL INSTITUTIONS - 0180

ANNOUNCEMENT OF MAXIMUM EFFECTIVE RATE OF INTEREST

The Federal National Mortgage Association has discontinued its free market auction system for commitments to purchase conventional home mortgages. Therefore, the Commissioner of Financial Institutions hereby announces that the maximum effective rate of interest per annum for home loans as set by the General Assembly in 1987, Public Chapter 291, for the month of July 2005 is 8.40 percent per annum.

The rate as set by the said law is an amount equal to four percentage points above the index of market yields of long-term government bonds adjusted to a thirty (30) year maturity by the U. S. Department of the Treasury. For the most recent weekly average statistical data available preceding the date of this announcement, the calculated rate is 4.40 percent.

Persons affected by the maximum effective rate of interest for home loans as set forth in this notice should consult legal counsel as to the effect of the Depository Institutions Deregulation and Monetary Control Act of 1980 (P.L. 96-221 as amended by P.L. 96-399) and regulations pursuant to that Act promulgated by the Federal Home Loan Bank Board. State usury laws as they relate to certain loans made after March 31, 1980, may be preempted by this Act.

Kevin P. Lavender

GOVERNMENT OPERATIONS COMMITTEES

ANNOUNCEMENT OF PUBLIC HEARINGS

For the date, time, and, location of this hearing of the Joint Operations committees, call 615-741-3642. The following rules were filed in the Secretary of State's office during the previous month. All persons who wish to testify at the hearings or who wish to submit written statements on information for inclusion in the staff report on the rules should promptly notify Fred Standbrook, Suite G-3, War Memorial Building, Nashville, TN 37243-0059, (615) 741-3074.

ANNOUNCEMENTS

SEQ. NO.	DATE FILED	DEPARTMENT AND DIVISION	TYPE OF FILING	DESCRIPTION	RULE NUMBER AND RULE TITLE	LEGAL CONTACT	EFFECTIVE DATE
05-01	May 2, 2005	0470 Board of Dietitian / Nutritionist Examiners	Rulemaking Hearing Rules	Amendment	<i>Chapter 0470 1</i> <i>General Rules and Regulations</i> 0470-1-.06 Fees	Nicole Armstrong Health OGC 26th Fl, TN Twr 312 8th Ave N Nashville, TN 37247-0120 615-741-161	July 16, 2005
05-05	May 5, 2005	0620 Department of Finance and Administration Bureau of TennCare	Public Necessity Rules	Amendments	<i>Chapter 1200-13-13</i> <i>TennCare Medicaid</i> 1200-13-13-.01 Definitions (TennCare Medicaid) 1200-13-13-.11 Appeal of Adverse Actions Affecting TennCare Services or Benefits (TennCare Medicaid)	J.D. Hickey Deputy Commissioner Finance and Administration	May 5, 2005 through Oct 17, 2005
05-06	May 5, 2005	1200 Health Bureau of TennCare	Public Necessity Rules	Amendments	<i>Chapter 1200-13-14</i> <i>TennCare Standard</i> 1200-13-14-.01 Definitions (TennCare Standard) 1200-13-14-.11 Appeal of Adverse Actions Affecting TennCare Services or Benefits (TennCare Standard)	J.D. Hickey Deputy Commissioner Finance and Administration	May 5, 2005 through Oct 17, 2005
05-07	May 9, 2005	0800 Labor and Workforce Development Division of Workers' Compensation	Proposed Rules	New Rules	<i>Chapter 0800-2-17</i> <i>Medical Cost Containment Program</i> 0800-2-17-.01 Purpose and Scope 0880-2-17-.02 Severability and Preemption 0800-2-17-.03 Definitions 0800-2-17-.04 Information Program Involving Rules 0800-2-17-.05 Procedure Codes/Adoption of CMS' Medicare Procedures, Guidelines and Amounts 0800-2-17-.06 Procedures for Which Codes Are Not Listed 0800-2-17-.07 Modifier Codes 0800-2-17-.08 Total Procedures Billed Separately 0800-2-17-.09 Independent Medical Examination to Evaluate Medical Aspects of Case 0800-2-17-.10 Payment 0800-2-17-.11 Reimbursement for Employee-Paid Services 0800-2-17-.12 Recovery of Payment 0800-2-17-.13 Penalties for Violations of Fee Schedule Rules 0800-2-17-.14 Missed Appointment 0800-2-17-.15 Medical Report of Initial Visit & Progress Reports for Other than Inpatient Hospital Care	E. Blaine Sprouse Workers' Compensation A Johnson Twr 2nd Fl Nashville TN 37243-0661 (615) 253-0064	Sept 28, 2005

ANNOUNCEMENTS

SEQ. NO.	DATE FILED	DEPARTMENT AND DIVISION	TYPE OF FILING	DESCRIPTION	RULE NUMBER AND RULE TITLE	LEGAL CONTACT	EFFECTIVE DATE
05-07, cont.					0800-2-17-.16 Additional Reports 0800-2-17-.17 Deposition/Witness Fee Limitation 0800-2-17-.18 Out-of-State Providers 0800-2-17-.19 Preauthorization 0800-2-17-.20 Process for Resolving Differences Between Carriers and Providers Regarding Bills 0800-2-17-.21 Administrative Review of Fee Schedule Disputes/Hearings 0800-2-17-.22 Utilization Review 0800-2-17-.23 Rule Review 0800-2-17-.24 Provider and Facility Fees for Copies of Medical Records 0800-2-17-.25 Penalties for Violations of Fee Schedule Rules and Medical Cost Containment Program Rules		
05-08	May 9, 2005	0800 Labor and Workforce Development Workers' Compensation	Proposed Rules	New Rules	<i>Chapter 0800-2-18</i> <i>Medical Fee Schedule</i> 0800-2-18-.01 Medicare-basis for System, Applicability, Effective Date and Coding References 0800-2-18-.02 General Information and Instructions for Use 0800-2-18-.03 General Guidelines 0800-2-18-.04 Surgery Guidelines 0800-2-18.05 Anesthesia Guidelines 0800-2-18-.06 Injections Guidelines 0800-2-18-.07 Ambulatory Surgical Centers and Outpatient Hospital Care (Including Emergency Room Facility Charges) 0800-2-18-.08 Chiropractic Services Guidelines 0800-2-18-.09 Physical and Occupational Therapy Guidelines 0800-2-18-.10 Durable Medical Equipment (DME) Guidelines 0800-2-18-.11 Orthotics, Prosthetics and Implants Guidelines 0800-2-18-.12 Pharmacy Schedule Guidelines 0800-2-18-.13 Ambulance Services Guidelines 0800-2-18-.14 Clinical Psychological Service Guidelines 0800-2-18-.15 Penalties for Violations of Fee Schedules	E. Blaine Sprouse Workers' Compensation A Johnson Twr 2nd Fl Nashville TN 37243-0661 (615) 253-0064	Sept 28, 2005

ANNOUNCEMENTS

SEQ. NO.	DATE FILED	DEPARTMENT AND DIVISION	TYPE OF FILING	DESCRIPTION	RULE NUMBER AND RULE TITLE	LEGAL CONTACT	EFFECTIVE DATE
05-09	May 9, 2005	0800 Labor and Workforce Development Division of Workers' Compensation	Proposed Rules	New Rules	Chapter 0800-2-19 In-Patient Hospital Fee Schedule 0800-2-19-.01 General Rules 0800-2-19-.02 Definitions 0800-2-19-.03 Special Ground Rules – Inpatient Hospital Services 0800-2-19-.04 Preauthorization 0800-2-19- 05 Other Services 0800-2-19-.06 Penalties for Violations of Fee Schedules	E. Blaine Sprouse Workers' Compensation A Johnson Twr 2nd Fl Nashville TN 37243-0661 (615) 253-0064	Sept 28, 2005
05-11	May 12, 2005	1660 Tennessee Wildlife Resources Agency	Rulemaking Hearing Rules	Amendment	<i>Chapter 1660-1-5 Rules and Regulations for Fishing</i> 1660-1-5-.03 TWRA Lakes	Sheryl Holtam, TWRA P.O. Box 40747 Nashville, TN 37204 (615) 781-6606	July 26, 2005
05-14	May 16, 2005	1200 Health Tennessee Medical Laboratory Board Division of Health Related Boards	Rulemaking Hearing Rules	Amendments	<i>Chapter 1200-6-00000000000003 General Rules Governing Medical Laboratories</i> 1200-6-3-.05 Licensure Discipline, Assessment of Costs, and Subpoenas 1200-6-3-.15 Special Regulations for ASTC, Blood Donor Centers and Plasma pheresis Centers	Robert J. Kraemer Health OGC 26th Fl TN Twr 312 8th Ave N Nashville TN 37247-0120 615-741-1611	July 30, 2005
05-16	May 19, 2005	0520 Board of Education	Proposed Rules	Amendments	<i>Chapter 0520-1-2 Administrative Rules and Regulations</i> 0520-1-2-.02 Salary Schedules 0520-1-2-.03 Employment Standards 0520-1-2-.03 Employment Standards <i>Chapter 0520-2-3 Teacher Education and Licensure</i> 0520-2-3-.01 Licensure, General Requirements <i>Chapter 0520-2-4 Licensure</i> 0520-2-4-.03 Alternative Licenses, Interim Licenses, and Permits 0520-2-4-.12 Requirements for the Professional School Service Personnel License	Mary Jo Howland State Board of Education 9th Fl A Johnson Twr 710 J Robertson Pkwy Nashville TN 37243-1050 (615) 741-2966	Sept 28, 2005
05-17	May 19, 2005	0520 Board of Education	Proposed Rules	Amendments	<i>Chapter 0520-1-3 Minimum Requirements for the Approval of Public Schools</i> 0520-1-3-.06 Graduation, Requirement E	Debra Owens State Board of Education 9th Fl A Johnson Twr 710 J Robertson Pkwy Nashville TN 37243-1050 (615) 741-2966	Sept 28, 2005

ANNOUNCEMENTS

SEQ. NO.	DATE FILED	DEPARTMENT AND DIVISION	TYPE OF FILING	DESCRIPTION	RULE NUMBER AND RULE TITLE	LEGAL CONTACT	EFFECTIVE DATE
05-18	May 19, 2005	0520 Board of Education	Proposed Rules	Amendments	<i>Chapter 0520-1-5 Pupil Transportation</i> 0520-1-5-.01 Operation of School Buses	Art Fuller State Board of Education 9th Fl A Johnson Twr 710 J Robertson Pkwy Nashville TN 37243-1050 (615) 741-2966	Sept 28, 2005
05-20	May 20, 2005	1240 Human Services Child Support Services Division	Public Necessity Rules	Amendments	<i>1240-2-2 Forms for Income Assignments</i> 1240-2-2-.04 Order/Notice to Withhold Income for Child Support (Order for Income Assignment) 1240-2-2-.12 Modified Order/Notice to Withhold Income for Child Support (Order for Income Assignment),	Kim Beals Human Services 400 Deaderick St Nashville TN 37248-0006 (615) 313-4731	May 20, 2005 through Nov 1, 2005
05-21	May 20, 2005	1240 Human Services Child Support Services Division	Public Necessity Rules	Amendments	<i>Chapter 1240-2-5 Liens for Child Support</i> 1240-2-5-.16 Child Support Lien Notice and Instructions	Kim Beals Human Services 400 Deaderick St Nashville TN 37248-0006 (615) 313-4731	May 20, 2005 through Nov 1, 2005
05-23	May 23, 2005	0320 Commission on Aging and Disability	Rulemaking Hearing Rules	Amendment	<i>Chapter 0030-2-1 State Funded Home and Community Based Services for Elderly and Disabled Adults</i> 0030-2-1-.02 Cost Sharing and Participant Contribution Requirements	Richard F. Russell OGC 26th Fl TN Twr 312 8th Ave N Nashville, TN 37247-0120 615-741-1611	Aug 6, 2005
05-24	May 24, 2005	0030 Commission on Aging and Disability	Rulemaking Hearing Rules	New Rules	<i>Chapter 0030-1-7 Cost Sharing for Services for the Elderly Provided Through Title III of the Older Americans Act</i> 0030-1-7-.01 Purpose 0030-1-7-.02 Services Exempt from Cost Sharing 0030-1-7-.03 Cost Sharing and Participant Contribution Requirement 0030-1-7-.04 Waiver	Nancy C. Peace 500 Deaderick St Suite 825 Nashville TN 37243-0860 615-741-2056	Aug 7, 2005
05-25	May 25, 2005	1660 Wildlife Resources Agency	Rulemaking Hearing Rules	Amendments	<i>Chapter 1660-1-2 Rules and Regulations for Birds</i> 1660-1-2-.02 Migratory Bird Hunting	Sheryl Holtam TWRA P.O. Box 40747 Nashville, TN 37204 (615) 781-6606	Aug 8, 2005

ANNOUNCEMENTS

SEQ. NO.	DATE FILED	DEPARTMENT AND DIVISION	TYPE OF FILING	DESCRIPTION	RULE NUMBER AND RULE TITLE	LEGAL CONTACT	EFFECTIVE DATE
05-26	May 25, 2005	0520 Board of Education	Rulemaking Hearing Rules	New Rules	<i>Chapter 0520-1-6</i> <i>Child Nutrition Programs</i> 0520-1-6-.04 Minimum Nutritional Standards for Individual Food Items Sold or Offered for Sale to Pupils in Grades Pre-Kindergarten through eight (Pre-K-8)	Rich Haglund General Counsel State Board of Education 710 J Robertson Pkwy 9th Fl Nashville TN 37243 (615) 741-2966	Aug 8, 2005
05-27	May 27, 2005	1200 Department of Health Bureau of Health Services Division of Maternal and Child Health	Proposed Rules	Amendments	<i>Chapter 1200-11-3</i> <i>Children's Special Services</i> 1200-11-3-.02 Definitions 1200-11-3-.03 Eligibility Requirements 1200-11-3-.04 Covered Services	Kassie Wiley Health OGC 26th Fl TN Twr 312 8th Ave N Nashville TN 37247 (615) 741-1611	Sept 28, 2005
05-45	May 31, 2005	0180 Department of Financial Institutions Bank Division	Proposed Rules	Amendments	<i>Chapter 0180-7</i> <i>Rules of Practice: Applications, Instructions, Forms, Reports of State Banks and Schedule of Application Fees for State Banks, BIDCOs, Savings Banks and Trust Companies</i> 0180-7-.08 Fees	Tina Miller 4th Fl Nashville City Center 511 Union St Nashville TN 615-532-1030	Sept 28, 2005

ANNOUNCEMENTS

TENNESSEE HEALTH SERVICES AND DEVELOPMENT AGENCY - 0720

NOTICE OF BEGINNING OF REVIEW CYCLE

Visit the Tennessee Health Services and Development Agency web site at: <http://www.state.tn.us/hsda/> for the latest Notice of Beginning of Review Cycle.

EMERGENCY RULES

EMERGENCY RULES NOW IN EFFECT

FOR TEXT OF EMERGENCY RULE SEE T.A.R. CITED

- 1240 - Department of Human Services - Child Support Services Division - Emergency rules pertaining to the calculation of additional expenses in split parenting cases and cases where parenting time is divided on a 50/50 basis, chapter 1240-2-4 Child Support Guidelines, 4 T.A.R., (April 2005) - Filed March 3, 2005; effective through August 15, 2005.
- 1360 - Department of State - Division of Charitable Solicitation - Charitable gaming Division - Emergency rules covering procedures for filing applications, amendments and financial accounting reports for organizations exempt from federal income taxation pursuant to Section 501(c)(3) of the Internal Revenue Code (IRC) who have been authorized by the Tennessee General Assembly to operate charitable gaming events, chapter 1360-3-2 Procedures for Operating Gaming Events, 4 T.A.R., (April 2005) - Filed March 4, 2005; effective through August 16, 2005.

PROPOSED RULES

STATE BOARD OF EDUCATION - 0520

CHAPTER 0520-1-2 ADMINISTRATIVE RULES AND REGULATIONS

CHAPTER 0520-2-3 TEACHER EDUCATION AND LICENSURE

CHAPTER 0520-2-4 LICENSURE

Presented herein are the proposed amendments of the State Board of Education submitted pursuant to T. C. A. § 4-5-202 in lieu of a rulemaking hearing. It is the intent of the State Board of Education to promulgate the amendments without a rulemaking hearing unless a petition requesting such hearing is filed within thirty (30) days of the publication date of the issue of the Tennessee Administrative Register in which the proposed amendments are published. Such petition to be effective must be filed with the State Board of Education, 9th Floor, Andrew Johnson Tower, 710 James Robertson Parkway, Nashville, Tennessee 37243-1050, and in the Department of State, 8th Floor – William Snodgrass Building, 312 8th Avenue North, Nashville, Tennessee 37243, and must be signed by twenty-five (25) persons who will be affected by the amendments, or submitted by a municipality which will be affected by the amendments, or an association of twenty-five (25) or more members, or any standing committee of the General Assembly.

For a copy of the proposed amendments, contact Mary Jo Howland, State Board of Education, 9th Floor, Andrew Johnson Tower, 710 James Robertson Parkway, Nashville, TN, 37243-1050, (615) 741-2966.

The text of the proposed amendments is as follows:

AMENDMENTS

Subparagraph (a) of paragraph (3) of Rule 0520-1-2-.02 Salary Schedules is amended by adding part 8 so that as amended the new part shall read as follows:

8. Verified experience as a licensed/certificated speech-language pathologist or audiologist in settings other than public or private schools may be counted for salary purposes on the system-wide salary schedule if approved by the local director of schools.

Paragraph (10) of Rule 0520-1-2-.03 Employment Standards is amended by adding subparagraphs (m) and (n) so that as amended the subparagraphs shall read as follows:

- (m) A school speech-language pathologist shall hold a license with the speech language pathologist endorsement.

PROPOSED RULES

- (n) An audiologist shall hold a license with audiologist endorsement.

Subparagraph (b) of paragraph (11) of Rule 0520-1-2-.03 Employment Standards is amended by deleting the subparagraph in its entirety and substituting instead the following language so that as amended the subparagraph shall read as follows:

- (b) A bachelor's level teacher of speech-language with a valid Tennessee teacher license with the appropriate endorsement employed prior to June 30, 2000 must make satisfactory progress toward achieving a master's degree or the equivalent to the master's degree in speech-language pathology by July 1, 2010. Satisfactory progress means completion of at least 5 graduate semester hours in speech language pathology or the equivalent education units offered in speech language pathology each year.

Paragraph (12) of Rule 0520-1-2-.03 Employment Standards is amended by deleting the paragraph in its entirety and substituting instead the following language so that as amended the paragraph shall read as follows:

- (12) Speech-Language. Individuals providing services to students with speech-language disabilities shall hold a valid license with a speech-language endorsement, be in a speech-language pathologist clinical fellowship, or be licensed as a speech-language pathologist by the Board of Communication Disorders and Sciences.

Authority: T.C.A. § 49-1-302.

AMENDMENTS

Rule 0520-2-3-.01 Licensure, General Requirements is amended by adding new paragraphs (19) and (20) so that as amended the paragraphs shall read as follows:

- (19) Candidates seeking licensure and endorsement as a school speech-language pathologist shall complete a program of studies in speech-language pathology at the graduate level. Candidates shall meet the licensure standards, employment standards and examination requirements of the State Board of Education.
- (20) Candidates seeking licensure and endorsement as a school audiologist shall complete a program of studies in audiology at the graduate level. Candidates shall meet the licensure standards, employment standards and examination requirements of the State Board of Education.

Authority: T.C.A. § 49-1-302.

AMENDMENTS

Subparagraph (a) of paragraph (1) of Rule 0520-2-4-.03 Alternative Licenses, Interim Licenses, and Permits is amended by adding a new part 6 so that as amended the part shall read as follows:

- 6. Alternative A license holders with endorsement as a speech-language teacher who have been admitted to master's degree program in speech-language pathology ac-

PROPOSED RULES

credited by the American Speech-Language Hearing Association may renew the license not more than four times provided that a director of schools states intent to employ. Before each renewal, the individual must complete at least six (6) graduate semester hours required by the program to which they have been admitted, unless all course requirements have been met.

Rule 0520-2-4-.12 Requirements for the Professional School Service Personnel License is amended by deleting the wording under the rule in its entirety and substituting instead the following language so that as amended the wording shall read as follows:

0520-2-4-.12 REQUIREMENTS FOR THE PROFESSIONAL SCHOOL SERVICE PERSONNEL LICENSE.

The professional school service personnel license requires at least a bachelor's degree and is issued to an applicant who has met the requirements for an endorsement as a school counselor, school psychologist, school social worker, school food service supervisor, school speech-language pathologist, and school audiologist. The license is valid for ten years and may be renewed in accordance with the same regulations that are specified for renewal of a Tennessee teacher professional license.

Paragraph (2) of Rule 0520-2-4-.12 Requirements for the Professional School Service Personnel License is amended by deleting the paragraph in its entirety and substituting instead the following language so that as amended the paragraph shall read as follows:

(2) School Speech-Language Pathologist

Candidates applying for a professional school service personnel license as a school speech-language pathologist shall satisfy one of the following criteria:

- (a) Applicants new to the field seeking initial professional school service personnel licensure shall complete a graduate degree in speech-language pathology from a state or regionally accredited institution of higher education with a speech-language graduate level program approved by the American Speech-Language-Hearing Association. They must also achieve a passing score on the examination required by the State Board of Education in Rule 0520-2-4-.05. Fully licensed teachers who are serving on employment standard waivers as speech-language teachers shall meet these requirements to be licensed as a school speech-language pathologist.
- (b) Speech-language pathologists who hold a valid license issued by Tennessee or an out-of-state licensing Board of Communication Disorders and Sciences or who hold the Certificate of Clinical Competence from the American Speech-Language-Hearing Association may be issued the professional school service personnel license upon application. There are no additional requirements.
- (c) Speech-language teachers who have a graduate degree or master's equivalence in speech-language pathology and hold a valid Tennessee teacher license with a speech-language endorsement may be issued the professional school service personnel license upon application.

PROPOSED RULES

- (d) Fully licensed bachelor's level speech-language teachers employed prior to July 1, 2000 may apply for the professional school services personnel license upon completion of the requirements for the master's equivalency. Candidates must earn at least five (5) graduate level semester hours each year and they must complete all program requirements prior to July 1, 2010.
- (e) Speech-language pathologists who have a graduate degree in speech-language pathology and hold a valid out-of-state educational credential issued before September 1, 2000, may be issued the professional school services personnel license upon application. Applicants with valid credentials issued on or after that date shall pass the examination required by the State Board of Education.

Rule 0520-2-4-.12 Requirements for the Professional School Service Personnel License is amended by adding paragraph (3) so that as amended the paragraph shall read as follows:

- (3) Candidates applying for a professional school service personnel license as a school audiologist shall satisfy one of the following criteria:
 - (a) Applicants new to the field seeking initial professional school services personnel licensure shall complete a graduate degree in audiology from a state or regionally accredited institution of higher education with a graduate level program approved by the American Speech-Language-Hearing Association.
 - (b) Audiologists who hold a valid license issued by Tennessee or an out-of-state licensing Board of Communication Disorders and Sciences or who hold the Certificate of Clinical Competence from the American Speech-Language-Hearing Association may be issued the professional school services personnel license upon application. There are no additional requirements.
 - (c) Audiologists who have a graduate degree in audiology and hold a valid out-of-state educational credential issued before September 1, 2000, may be issued the professional school service personnel license upon application. Applicants with valid credentials issued on or after that date shall pass the examination required by the State Board of Education.

Authority: T.C.A. § 49-1-302.

The proposed amendments set out herein were properly filed in the Department of State on the 19th day of May, 2005, pursuant to the instructions set out above, and in the absence of the filing of an appropriate petition calling for a rulemaking hearing, will become effective on the 28th day of September, 2005. (05-016)

PROPOSED RULES

STATE BOARD OF EDUCATION - 0520

**CHAPTER 0520-1-3
MINIMUM REQUIREMENTS FOR THE APPROVAL OF PUBLIC SCHOOLS**

Presented herein are the proposed amendments of the State Board of Education submitted pursuant to T. C. A. § 4-5-202 in lieu of a rulemaking hearing. It is the intent of the State Board of Education to promulgate the amendments without a rulemaking hearing unless a petition requesting such hearing is filed within thirty (30) days of the publication date of the issue of the Tennessee Administrative Register in which the proposed amendments are published. Such petition to be effective must be filed with the State Board of Education, 9th Floor, Andrew Johnson Tower, 710 James Robertson Parkway, Nashville, Tennessee 37243-1050, and in the Department of State, 8th Floor – William Snodgrass Building, 312 8th Avenue North, Nashville, Tennessee 37243, and must be signed by twenty-five (25) persons who will be affected by the amendments, or submitted by a municipality which will be affected by the amendments, or an association of twenty-five (25) or more members, or any standing committee of the General Assembly.

For a copy of the proposed amendments, contact Debra E. Owens, State Board of Education, 9th Floor, Andrew Johnson Tower, 710 James Robertson Parkway, Nashville, TN, 37243-1050, (615) 741-2966.

The text of the proposed amendments is as follows:

AMENDMENTS

Part 3 of subparagraph (e) of paragraph (1) of Rule 0520-1-3-.06 Graduation, Requirement E is amended by deleting the part in its entirety and substituting instead the following so that as amended the part shall read:

3. Computer Technology
 - (i) Computer Literacy
 - (ii) BASIC
 - (iii) Pascal
 - (iv) FORTRAN
 - (v) C
 - (vi) C++
 - (vii) JAVA
 - (viii) Advanced Placement Computer Science
 - (ix) Computer Applications
 - (x) Interactive Multimedia Design

PROPOSED RULES

- (xi) Adventures in Computing

Part 7 of subparagraph (e) of paragraph (1) of Rule 0520-1-3-.06 Graduation, Requirement E is amended by deleting the part in its entirety and substituting instead the following language so that as amended the part shall read:

7. Language Arts

- (i) English Language Arts I, II, III, IV
- (ii) English IV, Communication for Life*
- (iii) Advanced Placement English**
- (iv) Speech
- (v) Journalism
- (vi) Competency English
- (vii) Creative Writing
- (viii) Latin I, II, III, IV
- (ix) French I, II, III, IV
- (x) German I, II, III, IV
- (xi) Spanish I, II, III, IV
- (xii) Russian I, II, III, IV
- (xiii) Japanese I, II, III, IV
- (xiv) Other Languages I, II, III, IV
- (xv) English as a Second Language***

* This course satisfies the English IV credit required for graduation. At local discretion, this course may be offered in place of English III instead of English IV. The teacher shall hold an endorsement in English 7-12.

** Advanced Placement English programs of the College Board may substitute for English III or English IV.

*** Course work in English as a Second Language may be used to satisfy the English language requirement for graduation, not to exceed two units. Additional English as a Second Language course work may be awarded elective credits.

PROPOSED RULES

Part 2 of subparagraph (f) of paragraph (1) of Rule 0520-1-3-.06 Graduation, Requirement E is amended by deleting the part in its entirety and substituting instead the following language so that as amended the part shall read:

2. Health Science Education

- (i) Health Science Education
- (ii) Health Science Anatomy and Physiology*
- (iii) Medical Therapeutics
- (iv) Nursing Education
- (v) Rehabilitative Therapy
- (vi) Emergency Medical Services
- (vii) Health Informatics
- (viii) Support Services
- (ix) Diagnostic Medicine
- (x) Forensic Science
- (xi) Biomedical Applications
- (xii) Clinical Internship

* Health Science Anatomy & Physiology satisfies one of the science credits required for graduation or it may be offered for one vocational credit.

Part 4 through part 8 of subparagraph (f) of paragraph (1) of Rule 0520-1-3-.06 Graduation, Requirement E are amended by deleting the parts in their entirety and substituting instead the following language so that as amended the parts shall read:

4. Marketing Education

- (i) Marketing & Management I – Principles*
- (ii) Marketing & Management II – Advanced Strategies
- (iii) Financial Services Marketing*
- (iv) Entrepreneurship*
- (v) Services Marketing*
- (vi) Marketing Research & Analysis

PROPOSED RULES

- (vii) Retail Operations*
- (viii) Technical Marketing
- (ix) Advertising & Public Relations
- (x) Organizational Leadership
- (xi) Sales Management
- (xii) Sports and Entertainment Marketing
- (xiii) Wholesale-Logistics Operations*
- (xiv) International Business & Marketing*
- (xv) Exploration of Marketing & Management
- (xvi) Travel & Tourism
- (xvii) Hospitality Management
- (xviii) Foundations of Hospitality

* Completion of one of the core marketing education courses as signified by * satisfies the economics requirement for graduation.

5. Business Technology

- (i) Computer Applications
- (ii) Accounting I
- (iii) Accounting II
- (iv) American Business Legal Systems*
- (v) Business Principles
- (vi) Financial Planning
- (vii) Business Economics**
- (viii) BASIC Programming
- (ix) C++ Programming
- (x) JAVA Programming
- (ix) Keyboarding

PROPOSED RULES

- (x) International Business/Marketing**
- (xi) eBusiness Communications
- (xii) Business Management
- (xiii) Keyboarding/Document Formatting
- (xiv) Keyboarding/Document Layout & Design
- (xv) Spreadsheet Applications
- (xvi) Integrated Input Technologies
- (xvii) Database Design/Management
- (xviii) Administrative Management
- (xix) Desktop Publishing
- (xx) Computer Operating Systems
- (xxi) Career Connections
- (xxii) Computer Literacy
- (xxiii) Banking & Finance
- (xxiv) Interactive Multimedia Presentations
- (xxv) Virtual Enterprise International**
- (xxvi) Web Site - Foundations
- (xxvii) Web Page Design - Site Designer
- (xxviii) Web Page Design - eCommerce
- (xxix) Networking Essentials
- (xxx) Networking
- (xxxi) Information Technology Foundations

* American Business Legal Systems satisfies one-half credit in U.S. Government.

** Business Economics or International Business/Marketing or Virtual Enterprise International satisfy one-half credit in economics.

6. Technology Engineering Education

PROPOSED RULES

- (i) Foundations of Technology*
- (ii) Innovations and Inventions
- (iii) Technological Systems
- (iv) Engineering Processes
- (v) Problems and Solutions in Technology

* Foundations of Technology is applicable to grades 6 through 8.

7. Technology Preparation

- (i) Principles of Technology I*
- (ii) Principles of Technology II**
- (iii) Biology for Technology***
- (iv) Technical Mathematics****
- (v) Technical Algebra*****
- (vi) Technical Geometry*****
- (vii) English IV, Communication for Life*****

* Principles of Technology I satisfies one of the physical science credits required for graduation or it may be offered for one vocational credit.

** Principles of Technology II satisfies one science credit required for graduation. The completion of Principles of Technology I and II is equivalent to Physics I.

*** Biology for Technology satisfies one of the life science credits required for graduation.

**** Technical Mathematics may satisfy one of the mathematics credits allowed prior to entry in Algebra I or Technical Algebra, for students entering high school beginning in fall 2005.

***** Technical Algebra satisfies the Algebra I credit required for graduation.

***** Technical Geometry satisfies one of the math credits required for graduation.

***** English IV, Communication for Life, satisfies the English IV credit required for graduation. The teacher shall have an endorsement in English 7-12. At local discretion, this course may be offered in place of English III instead of English IV.

8. Trade and Industrial Education

PROPOSED RULES

- (i) Career Management Success
- (ii) Transportation Service Technology
 - (I) Transportation Core
 - (II) Aviation Maintenance I and II
 - (III) Introduction to Aerospace
 - (IV) Theory of Flight
 - (V) Automotive: Brake Systems
 - (VI) Automotive: Electrical/Electronic Systems
 - (VII) Automotive: Suspension and Steering
 - (VIII) Automotive: Engine Performance
 - (IX) Collision Repair: Non-Structural
 - (X) Collision Repair: Structural
 - (XI) Collision Repair: Painting and Refinishing
 - (XII) Diesel: Brake Systems
 - (XIII) Diesel: Preventive Maintenance
 - (XIV) Diesel: Suspension and Steering
 - (XV) Diesel: Electrical/Electronics
 - (XVI) Diesel: Engine
 - (XVII) Leisure Craft/Small Engine Technology: Engine Performance
 - (XVIII) Leisure Craft/Small Engine Technology: Systems
- (iii) Construction Technology
 - (I) Construction Core
 - (II) Computer-Aided Drafting
 - (III) Advanced Computer-Aided Drafting
 - (IV) Carpentry I and II

PROPOSED RULES

- (V) Concrete I and II
- (VI) Masonry I and II
- (VII) Electrical I and II
- (VIII) Heating, Ventilation, Air Conditioning and Refrigeration (HVAC/R)
I and II
- (IX) Plumbing I and II
- (X) Basic Principles of Welding
- (XI) Advanced Welding Applications
- (iv) Arts and Communication Technology
 - (I) Visual Communications
 - (II) Graphic Communications I
 - (III) Graphic Communications II
 - (IV) Digital Design and Imaging
 - (V) Media Concepts
 - (VI) Electronic Media Production
 - (VII) Electronic Media Management and Operations
 - (VIII) Information Technology Foundations
 - (IX) Computer Operating Systems & Hardware
 - (X) Networking
 - (XI) Cabling Technology
 - (XII) Web Site I – Foundations
 - (XIII) Web Page Design II – Site Designer
 - (XIV) Web Page Design III – eCommerce
- (v) Manufacturing Technology
 - (I) Programming and Logic
 - (II) Principles of Manufacturing
 - (III) Principles of Machining and Manufacturing

PROPOSED RULES

- (IV) Manufacturing Applications
- (V) Digital Electronics
- (VI) Computer-Aided Drafting
- (VII) Advanced Computer-Aided Drafting
- (VIII) Principles of Engineering
- (IX) Basic Principles of Welding
- (X) Advanced Welding Applications
- (vi) Human Services
 - (I) Principles of Cosmetology
 - (II) Design Principles of Cosmetology
 - (III) Chemistry of Cosmetology
 - (IV) Criminal Justice I, II, and III
- (vii) Hospitality and Tourism
 - (I) Foundations of the Hospitality Industry
 - (II) Culinary Arts I, II, and III

Authority: T.C.A. § 49-1-302.

The proposed amendments set out herein were properly filed in the Department of State on the 19th day of May, 2005, pursuant to the instructions set out above, and in the absence of the filing of an appropriate petition calling for a rulemaking hearing, will become effective on the 28th day of September, 2005. (05-17)

PROPOSED RULES

STATE BOARD OF EDUCATION - 0520

**CHAPTER 0520-1-5
PUPIL TRANSPORTATION**

Presented herein are the proposed amendments of the State Board of Education submitted pursuant to T. C. A. § 4-5-202 in lieu of a rulemaking hearing. It is the intent of the State Board of Education to promulgate the amendments without a rulemaking hearing unless a petition requesting such hearing is filed within thirty (30) days of the publication date of the issue of the Tennessee Administrative Register in which the proposed amendments are published. Such petition to be effective must be filed with the State Board of Education, 9th Floor, Andrew Johnson Tower, 710 James Robertson Parkway, Nashville, Tennessee 37243-1050, and in the Department of State, 8th Floor – William Snodgrass Building, 312 8th Avenue North, Nashville, Tennessee 37243, and must be signed by twenty-five (25) persons who will be affected by the amendments, or submitted by a municipality which will be affected by the amendments, or an association of twenty-five (25) or more members, or any standing committee of the General Assembly.

For a copy of the proposed amendments, contact Art Fuller, State Board of Education, 9th Floor, Andrew Johnson Tower, 710 James Robertson Parkway, Nashville, TN, 37243-1050, (615) 741-2966.

The text of the proposed amendments is as follows:

AMENDMENTS

Paragraph (4) of Rule 0520-1-5-.01 Operation of School Buses is amended by deleting the paragraph in its entirety and substituting instead the following language so that as amended the paragraph shall read:

- (4) Approved buses are identified as:
 - (a) Type C conventional buses with 15 years or less of service. After 12 years of service, year to year approval is required from the Commissioner of Education.
 - (b) Type D transit buses with 15 or less years of service.
 - (c) Type D transit buses with 150,000 miles or less of recorded travel and a maximum of 17 years in service.
 - (d) Type A buses with single rear wheels and 10 years or less of service.
 - (e) Type A buses with dual rear wheels and 12 years or less of service.
 - (f) Type C conventional buses remanufactured not later than the 10th nor earlier than the 7th year with 15 or less years of service.
 - (g) Type D transit buses remanufactured not later than the 15th nor earlier than the 12th year with 20 or less years of service.

Authority: T.C.A. § 49-1-302, 49-6-2102, 49-6-2109.

PROPOSED RULES

The proposed amendments set out herein were properly filed in the Department of State on the 19th day of May, 2005, pursuant to the instructions set out above, and in the absence of the filing of an appropriate petition calling for a rulemaking hearing, will become effective on the 28th day of September, 2005. (05-18)

RULEMAKING HEARINGS

**TENNESSEE DEPARTMENT OF FINANCIAL INSTITUTIONS - 0180
BANK DIVISION**

**CHAPTER 0180-7
RULES OF PRACTICE: APPLICATIONS, INSTRUCTIONS, FORMS, REPORTS OF STATE BANKS
AND
SCHEDULE OF APPLICATION FEES FOR STATE BANKS, BIDCOS,
SAVINGS BANKS AND TRUST COMPANIES**

Presented herein is a proposed amendment of the Department of Financial Institutions submitted pursuant to T.C.A. §4-5-202 in lieu of a rulemaking hearing. It is the intent of the Department of Financial Institutions to promulgate these amendments without a rulemaking hearing unless a petition requesting such hearing is filed within thirty (30) days of the publication date of the issue of the Tennessee Administrative Register in which the proposed amendment is published. Such petition to be effective must be filed in the Department of Financial Institutions, 4th Floor, Nashville City Center, 511 Union Street, Nashville, Tennessee, 37219 and in the Department of State, Eighth Floor, William R. Snodgrass Tower, 312 8th Avenue North, Nashville, Tennessee, 37243-0293 and must be signed by twenty-five (25) persons who will be affected by the rule, or submitted by a municipality which will be affected by the rule, or an association of twenty-five (25) or more members, or any standing committee of the General Assembly.

For a copy of the proposed amendments contact: Tina G. Miller, Staff Attorney, Tennessee Department of Financial Institutions, 4th Floor, Nashville City Center, 511 Union Street, Nashville, Tennessee, 37219, 615/532-1030.

The text of the proposed amendment is as follows:

SUBSTANCE OF PROPOSED RULES

AMENDMENTS

Rule 0180-7-.08 Fees, is amended by deleting the rule in its entirety and substituting the following language so that, as amended, it shall read as follows:

- (1) Following are the fees charged for each particular type of transaction:
 - (a) Application to organize a state bank, state BIDCO, state savings bank, state trust company or state credit card bank.....\$20,000.00
 - (b) Application/Notification to establish a branch office for a state bank, state BIDCO, state savings bank.....\$300.00
 - (c) Application/Notification to relocate a main office or branch by a state bank, state BIDCO, state savings bank.....\$300.00
 - (d) Application to relocate an office of a state trust institution\$300.00
 - (e) Application to form an interim bank.....\$1,000.00

RULEMAKING HEARINGS

- (f) Application for a merger where the resulting institution will be a state-chartered bank, state-chartered savings bank, state trust company or state BIDCO and any change of control application.....\$5,000.00
 - (g) Application for an acquisition where the resulting institution will be a state-chartered bank, state-chartered savings bank, state BIDCO or state trust company.....\$5,000.00
 - (h) Application to convert to a state bank, state savings bank or state trust company.\$3,000.00
 - (i) Application for a purchase and assumption transaction of less than substantially all of the assets of a bank by a state-chartered bank, savings bank, or a state BIDCO.....\$500.00
 - (j) Licensing fee per location for a state BIDCO.....\$500.00
 - (k) Application to engage directly or indirectly through a subsidiary in securities activities by a state bank, savings bank or state trust company.....\$1,000.00
 - (l) Filing fee for a state trust institution to establish or acquire a trust office.....\$500.00
 - (m) Application for private trust company status.....\$1,000.00
 - (n) Annual certification to maintain status as an exempt private trust company.....\$250.00
 - (o) Filing fee for conversion from private trust company to public trust company....\$10,000.00
 - (p) Application by a state-chartered bank or state trust company for a charter amendment that requires the approval of the shareholders.....\$100.00
 - (q) Application by a state-chartered bank or a state-chartered savings bank to begin exercising fiduciary powers.....\$100.00
 - (r) Application by a state-chartered bank or a state-chartered savings bank to establish an automated teller machine at a location other than a main office or branch location\$100.00
 - (s) Application by a state-chartered bank to engage in any expanded activity requiring approval under Rule 0180-19-.05.....\$1,000.00
- (2) If a process involves more than one transaction, the institution will be charged a separate fee for each application/notification.

Authority: T.C.A. §§ 45-1-107, 45-1-118, 45-2-103, 45-2-215, 45-2-218, 45-2-614, 45-2-1303, 45-2-1304, 45-2-1307, 45-2-1402, 45-2-1403, 45-2-1802, 45-2-1803, 45-2-1902, 45-3-1002, 45-3-1003, 45-8-204, 45-8-207, 45-8-208, 45-8-211, 45-8-214, 45-11-105, 45-14-103, 45-14-104, 45-14-110, 45-14-111, and 45-14-113.

The proposed rules set out herein were properly filed in the Department of State on the 31st day of May 2005, and pursuant to the instructions set out above, and in the absence of the filing of an appropriate petition calling for a rulemaking hearing, will become effective on the 28th day of September, 2005. (05-45)

PROPOSED RULES

**THE TENNESSEE DEPARTMENT OF HEALTH - 1200
BUREAU OF HEALTH SERVICES
DIVISION OF MATERNAL AND CHILD HEALTH**

**CHAPTER 1200-11-3
CHILDREN'S SPECIAL SERVICES**

Presented herein are proposed amendments of the Department of Health, Bureau of Health Services Administration, Children's Special Services, submitted pursuant to Tennessee Code Annotated 4-5-202 in lieu of a rulemaking hearing. It is the intent of the Department of Health, Bureau of Health Services Administration, Children's Special Services, to promulgate these rules without a rulemaking hearing unless a petition requesting such hearing is filed within thirty (30) days of the publication date of the issue of the Tennessee Administrative Register in which the proposed amendments are published. Such petition to be effective must be filed with the Office of Children's Special Services on the Fifth Floor of the Cordell Hull Building located at 425 Fifth Avenue North, Nashville, Tennessee, 37247, and in the Administrative Procedures Division of the Department of State, Eighth Floor, William R. Snodgrass Tennessee Tower, 312 Eighth Avenue North, Nashville, Tennessee, 37243, and must be signed by twenty-five (25) persons who will be affected by the amendments, or submitted by a municipality which will be affected by the amendments, or an association of twenty-five (25) or more members, or any standing committee of the General Assembly.

For copies of the entire text of the proposed amendments, contact: Greg Yopp, Director of Children's Special Services, Fifth Floor, Cordell Hull Building, 425 Fifth Avenue North, Nashville, Tennessee, 37247-4750, (615) 741-0361.

The text of the proposed amendments is as follows:

AMENDMENTS

Paragraph (9) of Rule 1200-11-3-.02, Definitions, is amended by creating a subparagraph (e) that shall read as follows:

- (e) If a child under the age of eighteen (18) is living with someone other than the parent or legal guardian, the parent or legal guardian's income will be considered when determining eligibility.

Authority: T.C.A. §§4-5-202, 68-1-103, and 68-12-101 et seq.

Paragraph (5), subparagraph (a) of Rule 1200-11-3-.03, Eligibility Requirements, is amended by deleting the language in subparagraph (a) in its entirety and adding instead the following language, so that, as amended, subparagraph (a) shall read:

- (a) Children without insurance coverage who meet financial and diagnostic guidelines will be enrolled in the program and assisted with applying to TennCare. Proof of applying to TennCare must be provided within ninety (90) days in order for clients to remain in the program.

Authority: T.C.A. §§4-5-202, 68-1-103, 68-12-103, and 68-12-112.

PROPOSED RULES

Paragraph (5), subparagraph (b) of Rule 1200-11-3-.03, Eligibility Requirements, is amended by deleting the language in subparagraph (b) in its entirety and adding instead the following language, so that, as amended, subparagraph (b) shall read:

- (b) Children who have access to other health insurance must apply for coverage under TennCare. Proof of applying for TennCare must be provided within ninety (90) days in order for clients to remain in the program. When a child enrolled in the program becomes covered by TennCare, resources from all other insurance payors will be exhausted before CSS considers payment for services. The program will coordinate services paid by other payors.

Authority: T.C.A. §§4-5-202, 68-1-103, 68-12-103, and 68-12-112.

Paragraph (5) of Rule 1200-11-3-.03, Eligibility Requirements, is amended by deleting subparagraph (c).

Authority: T.C.A. §§4-5-202, 68-1-103, 68-12-103, and 68-12-112.

Rule 1200-11-3-.04, Covered Services, is amended by deleting all language after “eligible for the program.” in paragraph (1), and adding instead the language “Covered services may include:”. Rule 1200-11-3-.04 is further amended by creating new paragraphs and subparagraphs, adding the following language, and renumbering the remaining paragraphs accordingly, so that, as amended, paragraphs (1) through (4) shall read:

- (1) Covered services are those described in Rule 1200-11-3-.02 that are not covered by other payors and are limited to those that directly relate to the diagnostic condition which made the child eligible for the program. Covered services may include:
 - (a) inpatient hospitalization; outpatient hospitalization or clinic services; care coordination services; orthodontic/dental intervention; pharmaceuticals and supplies such as medication, nutritional supplements, other supplies; durable medical equipment; standard rehabilitative therapies, assistive technology/augmentative communication devices, co-pay and deductibles; or other support services as determined by the Commissioner and the program;
 - (b) subsequent hospitalizations, clinic visits, routine care, medications (excluding immunosuppressive therapy), and supplies after transplant surgery, but not services for the surgery itself;
 - (c) subsequent hospitalizations, clinic visits, routine care, medications, and supplies after cochlear implant surgery, but not services for the surgery itself;
 - (d) rental or purchase of durable medical equipment; maintenance, repair, or replacement of durable medical equipment; and, where appropriate, training of the enrollee or the enrollee’s family in the use of the equipment.
- (2) For children with other insurance payors, those resources will be exhausted before the program considers payment.
- (3) If requested service is determined urgent, and is medically necessary, authorization may be granted by CSS, and reimbursements by insurers coordinated.

PROPOSED RULES

- (4) Any payment for services will conform to policies and procedures of the CSS program.

Authority: *T.C.A. §§4-5-202, 68-1-103, and 68-12-101 et seq.*

Newly-numbered paragraph (5), subparagraph (a) of Rule 1200-11-3-.04, Covered Services, is amended by deleting the language of subparagraph (a) in its entirety and adding instead the following language, so that, as amended, subparagraph (a) shall read:

- (a) Transplant surgeries and cochlear implants surgeries will not be covered. Medications and supplies used in transplant surgeries and cochlear implant surgeries also will not be covered.

Authority: *T.C.A. §§4-5-202, 68-1-103, and 68-12-101 et seq.*

Newly-numbered paragraph (5), subparagraph (f) of Rule 1200-11-3-.04, Covered Services, is amended by adding the words “as related to the child’s eligible CSS diagnosis.” after the word “another”, so that, as amended, subparagraph (f) shall read:

- (f) Ambulance fees and transportation will not be covered except for emergency transportation from one hospital to another, as related to the child’s eligible CSS diagnosis.

Authority: *T.C.A. §§4-5-202, 68-1-103, and 68-12-101 et seq.*

Newly-numbered paragraph (5), subparagraph (g) of Rule 1200-11-3-.04, Covered Services, is amended by adding the word “medical” after the word “CSS” and before “services”, so that, as amended, subparagraph (g) shall read:

- (g) Children admitted to a nursing home for continuous or episodic care will not be covered for CSS medical services until discharged.

Authority: *T.C.A. §§4-5-202, 68-1-103, and 68-12-101 et seq.*

The proposed rules set out herein were properly filed in the Department of State on the 27th day of May, 2005, and pursuant to the instructions set out above, and in the absence of the filing of an appropriate petition calling for a rulemaking hearing, will become effective on the 28th day of September, 2005. (05-27)

PROPOSED RULES

**THE TENNESSEE DEPARTMENT OF LABOR AND WORKFORCE DEVELOPMENT - 0800
DIVISION OF WORKERS' COMPENSATION**

**CHAPTER 0800-2-17
MEDICAL COST CONTAINMENT PROGRAM**

Presented herein are proposed rules of the Tennessee Department of Labor and Workforce Development submitted pursuant to T.C.A. Section 4-5-202 in lieu of a rulemaking hearing. It is the intent of the Tennessee Department of Labor and Workforce Development to promulgate these rules without a rulemaking hearing unless a petition requesting such hearing is filed within thirty (30) days of the publication date of the issue of the Tennessee Administrative Register in which the proposed rules are published. Such petition, to be effective, must be filed with the Workers' Compensation Division, Second Floor of the Andrew Johnson Tower located at 710 James Robertson Parkway, Nashville, TN 37243-0661 and in the Department of State, Eighth Floor, Tennessee Tower, William Snodgrass Building, 312 8th Avenue North, Nashville, TN 37243, and must be signed by twenty-five (25) persons who will be affected by the rule, or submitted by a municipality which will be affected by the rules, or an association of twenty-five (25) or more members, or any standing committee of the General Assembly.

For a copy of this proposed rule, contact: Vickie Gregory, Administrative Secretary, Tennessee Department of Labor and Workforce Development, Division of Workers' Compensation, Andrew Johnson Tower, Second Floor, 710 James Robertson Parkway, Nashville, TN 37243-0661, (615) 253-1613.

NEW RULES

TABLE OF CONTENTS

0800-2-17-.01	Purpose and Scope	0800-2-17-.14	Missed Appointment
0880-2-17-.02	Severability and Preemption	0800-2-17-.15	Medical Report of Initial Visit & Progress Reports for Other than Inpatient Hospital Care
0800-2-17-.03	Definitions	0800-2-17-.16	Additional Reports
0800-2-17-.04	Information Program Involving Rules	0800-2-17-.17	Deposition/Witness Fee Limitation
0800-2-17-.05	Procedure Codes/Adoption of CMS' Medicare Procedures, Guidelines and Amounts	0800-2-17-.18	Out-of-State Providers
0800-2-17-.06	Procedures for Which Codes Are Not Listed	0800-2-17-.19	Preauthorization
0800-2-17-.07	Modifier Codes	0800-2-17-.20	Process for Resolving Differences Between Carriers and Providers Regarding Bills
0800-2-17-.08	Total Procedures Billed Separately	0800-2-17-.21	Administrative Review of Fee Schedule Disputes/Hearings
0800-2-17-.09	Independent Medical Examination to Evaluate Medical Aspects of Case	0800-2-17-.22	Utilization Review
0800-2-17-.10	Payment	0800-2-17-.23	Rule Review
0800-2-17-.11	Reimbursement for Employee-Paid Services	0800-2-17-.24	Provider and Facility Fees for Copies of Medical Records
0800-2-17-.12	Recovery of Payment	0800-2-17-.25	Penalties for Violations of Fee Schedule Rules and Medical Cost Containment Program Rules
0800-2-17-.13	Penalties for Violations of Fee Schedule Rules		

0800-2-17-.01 PURPOSE AND SCOPE

- (1) Purpose. Pursuant to Tenn. Code Ann. §§ 50-6-204 (Supp. 2004), the following Medical Cost Containment Program Rules, together with the Medical Fee Schedule Rules, Chapter 0800-2-18-.01 et seq., and the In-patient Hospital Fee Schedule Rules, Chapter 0800-2-19.01 et seq., are hereby adopted by the Commissioner in order to establish a comprehensive medical fee schedule and a related system which includes, but is not limited to, procedures for review of charges, enforcement procedures and appeal hearings, to implement a medical fee schedule. The Commissioner promulgates these Medical Cost Containment Program Rules together with the Medical

PROPOSED RULES

Fee Schedule and In-patient Hospital Fee Schedule rules to establish the maximum allowable fees for health care services falling within the purview of the Tennessee Workers' Compensation Act ("Act"). These Medical Cost Containment Program Rules must be used in conjunction with the Medical Fee Schedule Rules and In-patient Hospital Fee Schedule Rules. The Medical Cost Containment Program Rules, Medical Fee Schedule Rules and In-patient Hospital Fee Schedule Rules (collectively herein "Rules") establish maximum allowable fees. Employers, carriers and providers may negotiate and contract lesser fees as are agreeable between them, but in no event shall reimbursement be in excess of the Rules, subject to the civil penalties prescribed in the Rules, as assessed by, and in the discretion of, the Commissioner, the Commissioner's designee, or an agency member appointed by the Commissioner.

- (2) Scope. These rules do all of the following:
- (a) Establish procedures by which the employer shall furnish, or cause to be furnished to an employee who receives a personal injury, or suffers an occupational disease, arising out of and in the course of employment, reasonable and necessary medical, surgical, and hospital services and medicines, or other attendance or treatment recognized by the laws of the state as legal, when needed. The employer shall also supply to the injured employee dental services, crutches, artificial limbs, eyes, teeth, eyeglasses, hearing apparatus, and other appliances necessary to cure, so far as reasonably and necessarily possible, and relieve from the effects of the injury or occupational disease.
 - (b) Establish schedules of maximum fees by a health facility or health care provider for such treatment or attendance, service, device, apparatus, or medicine.
 - (c) Establish procedures by which a health care provider shall be paid the lesser of: (1) the provider's usual charge, (2) the maximum fee established under these Rules, (3) or the MCO/PPO or any other negotiated and contracted price, where applicable. In no event shall reimbursement be in excess of these Rules. Reimbursement in excess of these Rules shall, at the Commissioner's discretion, result in civil penalties of ten thousand dollars (\$10,000.00) per violation each assessed severally against the provider accepting such fee and the carrier or employer paying the excessive fee, if a pattern or practice of such activity is found. At the Commissioner's discretion, such provider may also be reported to the appropriate certifying board, and may be subject to exclusion from participating in providing care under the Act.
 - (d) Identify utilization of health care and health services which is above the usual range of utilization for such services, based on medically accepted standards. Also to provide the ability by a carrier and the Division to obtain necessary records, medical bills, and other information concerning any health care or health service under review.
 - (e) Establish a system for the evaluation by a carrier of the appropriateness in terms of both the level of and the quality of health care and health services provided to injured employees, based upon medically accepted standards.
 - (f) Authorize carriers to withhold payment from, or recover payment from, health facilities or health care providers which have made excessive charges or which have required unjustified and/or unnecessary treatment, hospitalization, or visits.

PROPOSED RULES

- (g) Permit review by the Division of the records and medical bills of any health facility or health care provider which has been determined not to be in compliance with these Rules, or to be requiring unjustified and/or unnecessary treatment, hospitalization or office visits.
- (h) Establish that when a health care facility or health care provider provides health care or health care service that is not usually associated with, is longer in duration than, is more frequent than, or extends over a greater number of days than the health care or service usually does with a diagnosis or condition for which the patient is being treated, the health care provider may be required by the carrier to explain the necessity in writing.
- (i) Implement the Division's review and decision responsibility. These Rules and definitions are not intended to modify the workers' compensation laws, other administrative rules of the Division, or court decisions interpreting the laws or the Division's administrative rules.
- (j) Establish maximum fees for depositions/witnesses.
- (k) Establish maximum fees for medical reports.
- (l) Provide for uniformity of billing for provider services.
- (m) Establish the effective date for implementation of these Rules: These Rules shall be effective July 1, 2005 and are applicable to all medical services provided thereafter, regardless of the date of injury.
- (n) Adopt by reference as part of this rule the American Medical Association's CPT, Medical Fee Schedule, the In-patient Hospital Fee Schedule and any amendments to the fee schedule.
- (o) Establish procedures for reporting of medical claims.
- (p) Establish procedures for preauthorization of non-emergency hospitalizations, transfers between facilities, and outpatient services.
- (q) Establish procedures for imposing and collecting civil penalties for violations of these Rules.

Authority: T.C.A. §§50-6-118, 50-6-125, 50-6-128, 50-6-204, 50-6-205 (Supp. 2004), 50-6-233 (Repl. 1999).

0800-2-17-.02 SEVERABILITY AND PREEMPTION

If any provision of these Medical Cost Containment Program Rules, the Medical Fee Schedule Rules or the In-patient Hospital Fee Schedule Rules (collectively hereinafter "Rules") or the application thereof to any person or circumstance is for any reason held to be invalid, the remainder of the Rules and the application of the provisions to other persons or circumstances shall not be affected in any respect whatsoever. Whenever a conflict arises between these Rules and any other rule or regulation, these Rules shall prevail.

Authority: T.C.A. §§50-6-204, 50-6-205 (Supp. 2004), 50-6-233 (Repl. 1999).

PROPOSED RULES

0800-2-17-.03 DEFINITIONS

- (1) "Act" means Tennessee's Workers' Compensation Act, Tenn. Code Ann. §§50-6-101et seq., as amended.
- (2) "Adjust" means that a carrier or a carrier's agent reduces a health care provider's request for payment such as:
 - (a) Applies the Division's maximum fee;
 - (b) Applies an agreed upon discount to the provider's usual charge;
 - (c) Adjusts to a reasonable amount when the maximum fee is by report;
 - (d) Recodes a procedure;
 - (e) Reduces payment as a result of utilization review.
- (3) "Administrator" means the chief administrative officer of the Workers' Compensation Division of the Tennessee Department of Labor and Workforce Development.
- (4) "Appropriate care" means health care that is suitable for a particular person, condition, occasion, or place as determined by the Commissioner or the Commissioner's designee after consultation with the Medical Director.
- (5) "Bill" means a request by a provider submitted to a carrier for payment for health care services provided in connection with a compensable injury, illness or occupational disease.
- (6) "Bill adjustment" means a reduction of a fee on a provider's bill.
- (7) "BR" (By Report) means that the procedure is not assigned a maximum fee and requires a written description. The description shall be included on the bill or attached to the bill and shall include the following information, as appropriate:
 - (a) Copies of operative reports.
 - (b) Consultation reports.
 - (c) Progress notes.
 - (d) Office notes or other applicable documentation.
 - (e) Description of equipment or supply (when that is the charge).
- (8) "Carrier" means any stock company, mutual company, or reciprocal or inter-insurance exchange or self-insured employer authorized to write or carry on the business of workers' compensation insurance in this state; whenever required by the context, the term 'carrier' shall be deemed to include duly qualified self-insureds or self-insured groups.
- (9) "Case" means a compensable injury, illness or occupational disease identified by the worker's name and date of injury, illness or occupational disease.

PROPOSED RULES

- (10) "Case record" means the complete health care record maintained by the carrier pertaining to a compensable injury, illness or occupational disease and includes the circumstances or reasons for seeking health care; the supporting facts and justification for initial and continual receipt of health care; all bills filed by a health care service provider; and actions of the carrier which relate to the payment of bills filed in connection with a compensable injury, illness or occupational disease.
- (11) "CMS" means the U.S. Centers for Medicare & Medicaid Services (formerly HCFA).
- (12) "Commissioner" means the Commissioner of the Tennessee Department of Labor and Workforce Development, the Commissioner's designee, or an agency member appointed by the Commissioner.
- (13) "Complete procedure" means a procedure containing a series of steps which are not to be billed separately.
- (14) "Consultant service" means; in regard to the health care of a covered injury and illness; an examination, evaluation, and opinion rendered by a health care specialist when requested by the authorized treating practitioner or by the employee; and which includes a history, examination, evaluation of treatment, and a written report. If the consulting practitioner assumes responsibility for the continuing care of the patient, subsequent service(s) cease(s) to be a consultant service.
- (15) "Compensable injury, illness or occupational disease" means an injury, illness or occupational disease for which health care treatment is mandated under Tennessee Workers' Compensation Act.
- (16) "CPT" means the most current edition of the American Medical Association's Current Procedural Terminology.
- (17) "Critical care" has the same meaning as that in the most current version of the *CPT*.
- (18) "Day" means a calendar day, unless otherwise designated in these Rules.
- (19) "Department" means the Tennessee Department of Labor and Workforce Development.
- (20) "Diagnostic procedure" means a service which aids in determining the nature and cause of an occupational disease or injury.
- (21) "Division" means the Workers' Compensation Division of the Tennessee Department of Labor and Workforce Development.
- (22) "Dispute" means a disagreement between a carrier or a carrier's agent and a health care provider on the application of these Rules.
- (23) "DRG" (Diagnosis Related Group) means one of the classifications of diagnoses in which patients demonstrate similar resource consumption and length of stay patterns as for Medicare purposes by CMS (see "HCFA").
- (24) "Durable medical equipment" or "DME" is equipment which (1) can withstand repeated use, (2) is primarily and customarily used to serve a medical purpose, (3) generally is not useful to a person in the absence of illness, injury or occupational disease, and (4) is appropriate for use in the home.

PROPOSED RULES

- (25) "Established patient" has the same meaning as in the most current version of the *CPT*.
- (26) "Expendable medical supply" means a disposable article which is needed in quantity on a daily or monthly basis.
- (27) "Focused review" means the evaluation of a specific health care service or provider to establish patterns of use and dollar expenditures.
- (28) "Follow-up care" means the care which is related to the recovery from a specific procedure and which is considered part of the procedure's maximum allowable payment, but does not include care for complications.
- (29) "Follow-up days" means the days of care following a surgical procedure which are included in the procedure's maximum allowable payment, but does not include care for complications.
- (30) "Follow-up visits" means the number of office visits following a surgical procedure which is included in the procedure's maximum allowable payment, but does not include care for complications.
- (31) "HCFA" (now the "CMS") means the U.S. Centers for Medicare & Medicaid Services, formerly known as the Health Care Financing Administration of the U.S. Department of Health and Human Services.
- (32) "Health care organization" means a group of practitioners or individuals joined together to provide health care services and includes, but is not limited to, a freestanding surgical outpatient facility, health maintenance organization, an industrial or other clinic, an occupational health care center, a home health agency, a visiting nurse association, a laboratory, a medical supply company, or a community mental health center.
- (33) "Health care review" means the review of a health care case or bill, or both, by a carrier, or the carrier's agent.
- (34) "Health Care Specialist" means a board-certified practitioner, board-eligible practitioner, or a practitioner otherwise considered an expert in a particular field of health care service by virtue of education, training, and experience generally accepted by practitioners in that particular field of health care service.
- (35) "Health Care Specialist service" means, in regard to the health care of a compensable injury, illness or occupational disease, the treatment by a health care specialist, when requested by the treating practitioner, carrier, or by the employee, and includes a history, an examination, evaluation of medical data, treatment, and a written report.
- (36) "Inappropriate health care" means health care that is not suitable for a particular person, condition, occasion, or place as determined by the Commissioner or the Commissioner's designee after consultation with the Division's Medical Director.
- (37) "Incidental surgery" means a surgery performed through the same incision, on the same day, by the same doctor, and not related to the diagnosis.
- (38) "Independent medical examination" means an examination and evaluation conducted by a practitioner different from the practitioner providing care, other than one conducted under the Division's Medical Impairment Rating Registry (MIRR) Program.

PROPOSED RULES

- (39) "Independent procedure" means a procedure which may be carried out by itself, separate and apart from the total service that usually accompanies it.
- (40) "Inpatient services" mean services rendered to a person who is formally admitted to a hospital and whose length of stay exceeds 23 hours.
- (41) "Institutional services" mean all non-physician services rendered within the institution by an agent of the institution.
- (42) "Maximum allowable payment" means the maximum fee for a procedure established by these Rules or the provider's usual and customary charge, whichever is less, except as otherwise might be specified. In no event shall reimbursement be in excess of the Division's Medical Fee Schedule Rules. Reimbursement in excess of the Division's Fee Schedule Rules may, at the Commissioner's discretion, result in civil penalties of ten thousand dollars (\$10,000.00) per violation for each violation, assessed severally against both the provider accepting such fee and the carrier or employer paying the excessive fee, whenever a pattern or practice of such activity is found. At the Commissioner's discretion, such provider may also be reported to the appropriate certifying board, and may be subject to exclusion from participating in providing care under the Act.
- (43) "Maximum fee" means the maximum allowable fee for a procedure established by this rule, the Medical Fee Schedule and the In-patient Hospital Fee Schedule.
- (44) "Medical admission" means any hospital admission where the primary services rendered are not surgical, psychiatric, or rehabilitative in nature.
- (45) "Medically accepted standard" means a measure which is set by a competent authority as the rule for evaluating quantity or quality of health care or health care services and which may be defined in relation to any of the following:
- (a) Professional performance.
 - (b) Professional credentials.
 - (c) The actual or predicted effects of care.
 - (d) The range of variation from the norm.
- (46) "Medically appropriate care" means health care that is suitable for a particular person, condition, occasion, or place.
- (47) "Medical Director" means the Division's Medical Director appointed by the Commissioner pursuant to T.C.A. §§ 50-6-126 (Repl. 1999)
- (48) "Medical only case" means a case which does not involve lost work time.
- (49) "Medical supply" means either a piece of durable medical equipment or an expendable medical supply.
- (50) "Modifier code" means a 2-digit number used in conjunction with the procedure code to describe unusual circumstances which arise in the treatment of an injured or ill employee.

PROPOSED RULES

- (51) "New patient" means a patient who is new to the provider for a particular compensable injury, illness or occupational disease and who needs to have medical and administrative records established.
- (52) "Operative report" means the practitioner's written description of the surgery and includes all of the following:
- (a) A preoperative diagnosis.
 - (b) A postoperative diagnosis.
 - (c) A step-by-step description of the surgery.
 - (d) An identification of problems which occurred during surgery.
 - (e) The condition of the patient, when leaving the operating room, the practitioner's office, or the health care organization.
- (53) "Ophthalmologist" shall be defined according to T.C.A. §§71-4-102(3).
- (54) "Optician" shall mean a licensed dispensing optician as set forth in T.C.A. §§63-14-103.
- (55) "Optometrist" means an individual licensed to practice optometry.
- (56) "Optometry" shall be defined according to T.C.A. §§63-8-102.
- (57) "Orthotic equipment" means an orthopedic apparatus designed to support, align, prevent, correct deformities, or improve the function of a movable body part.
- (58) "Orthotist" means a person skilled in the construction and application of orthotic equipment.
- (59) "Outpatient service" means a service provided by the following, but not limited to, types of facilities: physicians' offices and clinics, hospital emergency rooms, hospital outpatient facilities, community mental health centers, outpatient psychiatric hospitals, outpatient psychiatric units, and freestanding surgical outpatient facilities also known as ambulatory surgical centers.
- (60) "Package" means a surgical procedure that includes but is not limited to all of the following components:
- (a) The operation itself.
 - (b) Local infiltration.
 - (c) Topical anesthesia when used.
 - (d) The normal, uncomplicated follow-up care/visits. This includes a standard postoperative period of 30 days.
- (61) "Pharmacy" means the place where the science, art, and practice of preparing, preserving, compounding, dispensing, and giving appropriate instruction in the use of drugs is practiced.

PROPOSED RULES

- (62) "Practitioner" means a person licensed, registered, or certified as an audiologist, doctor of chiropractic, doctor of dental surgery, doctor of medicine, doctor of osteopathy, doctor of podiatry, doctor of optometry, nurse, nurse anesthetist, nurse practitioner, occupational therapist, orthotist, pharmacist, physical therapist, physician's assistant, prosthetist, psychologist, or other person licensed, registered, or certified as a health care professional.
- (63) Prevailing Charge: The charge at the 50th percentile in any array of weighted customary charges made for the same geographical location. This is the upper limit of charges allowed for reimbursement of services which have no Medicare amount available and are not assigned a fee in the Tennessee Workers' Compensation Medical and In-patient Fee Schedules.
- (64) "Primary procedure" means the therapeutic procedure most closely related to the principle diagnosis.
- (65) "Procedure" means a unit of health service.
- (66) "Procedure code" means a 5-digit numerical sequence or a sequence containing an alpha or alphas and followed by three or four digits, which identifies the service performed and billed.
- (67) "Properly submitted bill" means a request by a provider for payment of health care services submitted to a carrier on the appropriate forms which are completed pursuant to this rule. Properly submitted bills shall include appropriate documentation as required by this rule.
- (68) "Prosthesis" means an artificial substitute for a missing body part.
- (69) "Prosthetist" means a person skilled in the construction and application of prosthesis.
- (70) "Provider" means a facility, health care organization, or a practitioner.
- (71) "Reasonable amount" means a payment based upon the amount generally paid in the state for a particular procedure code using data available from but not limited to the provider, the carrier, or the Tennessee Workers' Compensation Division.
- (72) "Reject" means that a carrier or a carrier's agent denies payment to a provider or denies a provider's request for reconsideration.
- (73) "Secondary procedure" means a surgical procedure which is performed to ameliorate conditions that are found to exist during the performance of a primary surgery and which is considered an independent procedure that may not be performed as a part of the primary surgery or for the existing condition.
- (74) "Stop-Loss Payment" or "SLP" means an independent method of payment for an unusually costly or lengthy stay.
- (75) "Stop-Loss Reimbursement Factor" or "SLRF" means a factor established by the Commissioner to be used as a multiplier to establish a reimbursement amount when total hospital charges have exceeded specific stop-loss thresholds.
- (76) "Stop-Loss Threshold" or "SLT" means a threshold of charges established by the Commissioner, beyond which reimbursement is calculated by multiplying the applicable SLRF times the total charges identifying that particular threshold.

PROPOSED RULES

- (77) "Surgical admission" means any hospital admission where there is an operating room charge, the patient with has a surgical procedure code, or the patient has a surgical DRG as defined by the CMS.
- (78) "Transfer between facilities" means to move or remove a patient from one facility to another for a purpose related to obtaining or continuing medical care. The transfer may or may not involve a change in the admittance status of the patient, i.e., patient transported from one facility to another to obtain specific care, diagnostic testing, or other medical services not available in the facility in which the patient has been admitted. The transfer between facilities shall include costs related to transportation of patient to obtain medical care.
- (79) "Usual and customary charge" means a particular provider's average charge for a procedure to all payment sources, and includes itemized charges previously billed separately which are included in the package for that procedure as defined by these Rules.
- (80) "UB-92, HCFA-1450, 1500 or CMS-1450" means the health insurance claim form maintained by HCFA/CMS for use by institutional care providers. Currently this form is known as the UB-92.
- (82) "Workers' Compensation Standard Per Diem Amount" or "SPDA" means a standardized per diem amount established for the reimbursement of hospitals for services rendered.

Authority: T.C.A. §§50-6-102, 50-6-204 (Supp. 2004).

0800-2-17-.04 INFORMATION PROGRAM INVOLVING RULES

The Division may institute an ongoing information program regarding these Rules for providers, carriers, employees and employers. The program may include, at a minimum, informational sessions throughout the state, as well as the distribution of appropriate information materials.

Authority: T.C.A. §§50-6-102, 50-6-204 (Supp. 2004).

0800-2-17-.05 PROCEDURE CODES/ADOPTION OF THE CMS' MEDICARE PROCEDURES, GUIDELINES AND AMOUNTS

- (1) Services and medical supplies must be coded with valid procedure or supply codes of the *Health Care Financing Administration Common Procedure Coding System* ("HCPCS"). Procedure codes used in these rules were developed and copyrighted by the American Medical Association.
- (2) The most current edition of the American Medical Association's *Current Procedural Terminology* ("CPT") should be used with these Rules.
- (3) Unless otherwise specifically stated in these Rules, the most current Medicare procedures and guidelines are hereby adopted and incorporated as part of these Rules as if fully set out herein and are effective upon adoption and implementation by the CMS. Whenever there is no specific fee or methodology for reimbursement set forth in these Rules for a service, diagnostic procedure, equipment, etc., then the amount of reimbursement shall be at 100% of the 2005 CMS' Medicare amount and the most current effective Medicare guidelines and procedures shall be followed in arriving at the correct amount. The Medicare amount may, upon review by and at the Commissioner's discretion, be adjusted upward annually based upon the annual Medicare Economic Index adjustment, but this amount shall never fall below the effective 2005 Medicare

PROPOSED RULES

amount. Whenever there is no applicable Medicare code or methodology, the service, equipment, diagnostic procedure, etc. shall be reimbursed at the lesser of the usual and customary or the prevailing charge amount and be billed By Report ("BR").

Authority: T.C.A. §§50-6-204, 50-6-205 (Supp. 2004), 50-6-233 (Repl. 1999).

0800-2-17-.06 PROCEDURES FOR WHICH CODES ARE NOT LISTED

- (1) If a procedure is performed which is not listed in the Medicare *Resource Based Relative Value Scale* ("RBRVS"), the health care provider must use an appropriate CPT procedure code. The provider must submit an explanation, such as copies of operative reports, consultation reports, progress notes, office notes or other applicable documentation, or description of equipment or supply (when that is the charge).
- (2) The CPT contains procedure codes for unlisted procedures. These codes should only be used when there is no procedure code which accurately describes the service rendered. A special report is required as these services are reimbursed By Report ("BR").
- (3) Reimbursement by the carrier for BR procedures should be based upon the carrier's review of the submitted documentation, the recommendations from the carrier's medical consultant, and the carrier's review of the prevailing charges for similar services as identified by the carrier based on data which is representative of Tennessee charges.

Authority: T.C.A. §§50-6-204, 50-6-205 (Supp. 2004), 50-6-233 (Repl. 1999).

0800-2-17-.07 MODIFIER CODES

- (1) Modifiers listed in the most current CPT shall be added to the procedure code when the service or procedure has been altered from the basic procedure described by the descriptor.
- (2) The use of modifiers does not imply or guarantee that a provider will receive reimbursement as billed. Reimbursement for modified services or procedures must be based on documentation of reasonableness and necessity and must be determined on a case-by-case basis.
- (3) When Modifier 21, 22, or 25 is used, a report explaining the medical necessity of the situation must be submitted to the carrier. It is not appropriate to use Modifier 21, 22, or 25 for routine billing.

Authority: T.C.A. §§50-6-204, 50-6-205 (Supp. 2004), 50-6-233 (Repl. 1999).

0800-2-17-.08 TOTAL PROCEDURES BILLED SEPARATELY

- (1) Certain diagnostic procedures (neurological testing, radiology and pathology procedures, etc.) may be performed by two separate entities that also bill separately for the professional and technical components. When this occurs, the total reimbursement must not exceed the maximum medical fee schedule allowable for the 5-digit procedure code listed.
 - (a) When billing for the professional component only, Modifier 26 must be added to the appropriate 5-digit procedure code.

PROPOSED RULES

- (b) When billing for the technical component only, Modifier TC (Technical Component) must be added to the appropriate 5-digit code.

Authority: T.C.A. §§50-6-128, 50-6-204, 50-6-205 (Supp. 2004).

0800-2-17-.09 INDEPENDENT MEDICAL EXAMINATION TO EVALUATE MEDICAL ASPECTS OF CASE

- (1) An independent medical examination, other than one conducted under the Division's Medical Impairment Rating Registry ("MIRR") Program, shall include a study of previous history and medical care information, diagnostic studies, diagnostic x-rays, and laboratory studies, as well as an examination and evaluation. This service may be necessary in order to make a judgment regarding the current status of the injured or ill worker, or to determine the need for further health care.
- (2) An independent medical examination, performed to evaluate the medical aspects of a case (other than one conducted under the Division's MIRR Program), shall be billed using the independent medical examination procedure code 99455 or 99456 (BR), and shall include the practitioner's time only. Time spent shall include face-to-face time with the patient, time spent reviewing records, reports and studies, and time spent preparing reports. The office visit charge is included with the code 99455 or 99456 and shall not be billed separately.
- (3) Any laboratory procedure, x-ray procedure, and any other test which is needed to establish the worker's ability to return to work shall be identified by the appropriate procedure code established by this rule and reimbursed accordingly.

Authority: T.C.A. §§50-6-204, 50-6-205 (Supp. 2004), 50-6-233 (Repl. 1999).

0800-2-17-.10 PAYMENT

- (1) Reimbursement for all health care services and supplies shall be the lesser of (a) the provider's usual charge, or (b) the maximum fee calculated according to these Rules (and/or any amendments to these Rules), or (c) the MCO/PPO or any other contracted price, wherever applicable. A licensed provider shall receive no more than the maximum allowable payment, in accordance with these Rules, for appropriate health care services rendered to a person who is entitled to health care services under the Act.
- (2) The most current Medicare RBRVS is adopted by reference as part of these Rules. The Medicare RBRVS is distributed by the Office of the Federal Register and is also available on the Internet at www.cms.hhs.gov/medicare. Whenever a different guideline or procedure is not set forth in these Rules, the most current effective Medicare guidelines and procedures shall be followed.
- (3) When extraordinary services resulting from severe head injuries, major burns, and severe neurological injuries or any injury requiring an extended period of intensive care are required, a greater fee may be allowed up to 150% of the professional service fees normally allowed under these Rules. Such cases shall be billed with modifier 21 or 22 (for CPT coded procedures) and shall contain a detailed written description of the extraordinary service rendered and the need therefore. This provision does not apply to In-patient Hospital Care facility fees which are specifically addressed in the In-patient Hospital Fee Schedule Rules, 0800-2-19-.01 et seq.

PROPOSED RULES

- (4) Billing for provider services shall be submitted on the forms approved by the Division: UB-92 and HFCA-1500, or their official replacement forms.
- (5) A carrier shall not make a payment for a service unless all required review activities pertaining to that service are completed.
- (6) A carrier's payment shall reflect any adjustments in the bill made through the carrier's utilization review program.
 - (a) A carrier must provide an explanation of medical benefits to a health care provider whenever the carrier's reimbursement differs from the amount billed by the provider.
 - (b) A provider shall not attempt to collect from the injured employee, employer, or carrier any amounts properly reduced by the carrier pursuant to this rule.
- (7) A carrier shall date stamp medical bills and reports upon receipt and shall pay an undisputed and properly submitted bill within thirty-one (31) calendar days of receipt. Any carrier that fails to pay an undisputed and properly submitted bill within thirty-one (31) calendar days of receipt shall be assessed a civil penalty of 2.08% monthly (25% annual percentage rate ("APR")). The 2.08% monthly civil penalty (25% APR) shall be compounded monthly and shall be payable to the provider at the time of reimbursement.
- (8) When a carrier disputes a bill or portion thereof, the carrier shall pay the undisputed portion of the bill within thirty-one (31) calendar days of receipt of a properly submitted bill. Any carrier not paying an undisputed portion of the bill within thirty-one (31) calendar days of receipt shall be assessed a civil penalty of 2.08% monthly (25% APR) on the undisputed portion of the bill. The 2.08% monthly civil penalty (25% APR) shall be compounded monthly and shall be payable to the provider at the time of reimbursement.
- (9) Any provider not receiving timely payment of the undisputed portion of the provider's bill may institute a collection action in a court having proper jurisdiction over such matters to obtain payment of the bill, together with the interest civil penalty of 25% APR. Such providers, if they prevail, shall also be entitled to reasonable costs and attorney fees incurred in such collection actions to be paid by the carrier or self-insured employer.
- (10) Billings not submitted on the proper form, as prescribed in these Rules, the In-patient Hospital Fee Schedule Rules, and the Medical Fee Schedule Rules, may be returned to the provider for correction and resubmission. If a carrier returns such billings, it must do so within 20 calendar days of receipt of the bill. The number of days between the date the carrier returns the billing to the provider and the date the carrier receives the corrected billing, shall not apply toward the thirty-one (31) calendar days within which the carrier is required to make payment.
- (11) Payments to providers for initial examinations and treatment authorized by the carrier or a self-insured employer shall be paid by that carrier or self-insured employer and shall not later be subject to reimbursement by the employee or another medical insurance program, even if the injury or condition for which the employee was sent to the provider is later determined non-compensable under the Act.

Authority: T.C.A. §§50-6-204, 50-6-205 (Supp. 2004), 50-6-233 (Repl. 1999).

PROPOSED RULES

0800-2-17-.11 REIMBURSEMENT FOR EMPLOYEE-PAID SERVICES

Notwithstanding any other provision of this rule, if an employee has personally paid for a health care service and at a later date a carrier is determined to be responsible for the payment, then the employee shall be fully reimbursed by the carrier.

Authority: T.C.A. §§50-6-128, 50-6-204, 50-6-205 (Supp. 2004).

0800-2-17-.12 RECOVERY OF PAYMENT

- (1) Nothing in this rule shall preclude the recovery of payment already made for services and bills which may later be found to have been medically paid at an amount which exceeds the maximum allowable payment. This also includes payments reimbursed to an employee pursuant to 0800-2-17-.11 above.
- (2) A carrier may recover a payment to a provider, whether by an employee or a carrier, if the carrier requests the provider for the recovery of the payment, with a statement of reasons for the request, within one year of the date of payment.
- (3) Within thirty-one (31) calendar days of receipt of the carrier's request for recovery of the payment, the provider shall do either of the following:
 - (a) If in agreement with the request, refund the payment to the carrier.
 - (b) If not in agreement with the request, supply the carrier with a written detailed statement of the reasons for its disagreement, along with a refund of the portion, if any, of the payment that the provider agrees should be refunded.
- (4) If the carrier does not accept the reason for disagreement supplied by the provider, the carrier may file a request for Administrative Review, within thirty-one (31) calendar days of receipt of the provider's statement of disagreement. The request for review shall be filed with the Medical Director for a recommendation by the Medical Care and Cost Containment Committee (MCCCC). The carrier shall supply a copy to the provider.
- (5) If, within 62 calendar days of the carrier's request for recovery of a payment, the carrier does not receive either a full refund of the payment or a statement of disagreement, then, at the option of the carrier, the carrier may do either or both of the following:
 - (a) File a request for Administrative Review as outlined above, of which the carrier shall supply a copy to the provider.
 - (b) Reduce the payable amount on the provider's subsequent bills (in the case in question or any other case) to the extent of the request for recovery of payment.
- (6) If, within thirty-one (31) calendar days of a recommendation from the MCCCC, a provider does not pay in full any refund recommended, the carrier may reduce the payable amount on the provider's subsequent bills to the extent of the request for recovery of payment, plus an additional 25% per annum. The carrier may, at its discretion, pursue recovery of such refund in a court of law with proper jurisdiction pursuant to T.C.A. §§ 50-6-226.

Authority: T.C.A. §§50-6-204, 50-6-205, 50-6-226 (Supp. 2004), 50-6-233 (Repl. 1999).

PROPOSED RULES

0800-2-17-.13 PENALTIES FOR VIOLATIONS OF FEE SCHEDULE RULES

- (1) Providers shall not accept, and employers or carriers shall not pay any amount for health care services provided for the treatment of a covered injury or illness or for any other services encompassed within the Medical Cost Containment Program Rules, Medical Fee Schedule Rules or the In-patient Hospital Fee Schedule Rules, when that amount exceeds the maximum allowable payment established by these Rules. Any provider accepting and any employer or carrier paying an amount in excess of the Division's Medical Cost Containment Program Rules, Medical Fee Schedule Rules or the In-patient Hospital Fee Schedule Rules shall be in violation of these Rules and may, at the Commissioner's discretion, be subject to civil penalties of ten thousand dollars (\$10,000.00) per violation for each violation, which may be assessed severally against both the provider accepting such fee, and the carrier or employer paying the excessive fee, whenever a pattern or practice of such activity is found. At the discretion of the Commissioner, the Commissioner's Designee, or an agency member appointed by the Commissioner, such provider may also be reported to the appropriate certifying board, and may be subject to exclusion from participating in providing care under the Act. Any other violation of the Medical Cost Containment Program Rules, Medical Fee Schedule Rules, or the In-patient Hospital Fee Schedule Rules may subject the violator(s) to a civil penalty of not less than one hundred dollars (\$100.00) nor more than ten thousand dollars (\$10,000.00) per violation, at the discretion of the Commissioner, Commissioner's Designee, or an agency member appointed by the Commissioner.

- (2) A provider, employer or carrier found to be in violation of these Rules, whether a civil penalty is assessed or not, may request a contested case hearing by requesting the hearing in writing within fifteen (15) calendar days of issuance of a Notice of Violation and, if applicable, notice of the assessment of civil penalties. If a request for hearing is not received by the Division within the fifteen (15) calendar days of issuance of the Notice of

Violation, the determination of such violation shall be deemed a final order of the Department and not subject to further review.

- (3) A request for hearing shall be made to the Division in writing by an employer, carrier or provider notified of violation of these Rules.
- (4) Any request for a hearing shall be filed with the Division within fifteen (15) calendar days of the date of issuance of the Notice of Violation and, if applicable, of civil penalty. Failure to file a request for a hearing within fifteen (15) calendar days of the date of issuance of the Notice of Violation shall result in the decision of the Commissioner, Commissioner's Designee, or an agency member appointed by the Commissioner becoming a final order and not subject to further review.

The Commissioner, Commissioner's Designee, or an agency member appointed by the Commissioner shall have the authority to hear the matter as a contested case and determine if any civil penalty assessed should have been assessed.

Upon receipt of a timely filed request for a hearing, the Division shall issue a Notice of Hearing to all interested parties.

Authority: T.C.A. §§50-6-118, 50-6-125, 50-6-128, 50-6-204, 50-6-205 (Supp. 2004), 50-6-233 (Repl. 1999).

PROPOSED RULES

0800-2-17-.14 MISSED APPOINTMENT

A provider shall not receive payment for a missed appointment unless the appointment was arranged by the Division, carrier or the employer. If the carrier or employer fails to cancel the appointment not less than one (1) business day prior to the time of the appointment, the provider may bill the carrier for the missed appointment using procedure code 99199 with a maximum fee of BR.

Authority: T.C.A. §§50-6-204, 50-6-205 (Supp. 2004), 50-6-233 (Repl. 1999).

0800-2-17-.15 MEDICAL REPORT OF INITIAL VISIT AND PROGRESS REPORTS FOR OTHER THAN INPATIENT HOSPITAL CARE

- (1) Except for inpatient hospital care, a provider shall furnish the carrier with a narrative medical report for the initial visit, all information pertinent to the compensable injury, illness, or occupational disease if requested within thirty (30) days after examination or treatment of the injured employee, and a progress report for every 60 days of continuous treatment for the same compensable injury, illness or occupational disease.
- (2) If the provider continues to treat an injured or ill employee for the same compensable injury, illness or occupational disease at intervals which exceed 60 calendar days, then the provider shall provide a progress report following each treatment that is at intervals exceeding 60 calendar days.
- (3) The narrative medical report of the initial visit and the progress report shall include all of the following information:
 - (a) Subjective complaints and objective findings, including interpretation of diagnostic tests.
 - (b) For the narrative medical report of the initial visit, the history of the injury, and for the progress report(s), significant history since the last submission of a progress report.
 - (c) The diagnosis.
 - (d) As of the date of the narrative medical report or progress report, the projected treatment plan, including the type, frequency, and estimated length of treatment.
 - (e) Physical limitations.
 - (f) Expected work restrictions and length of time if applicable.
- (4) Cost of the narrative medical reports required by 0800-2-17-.15(1) and (2) shall be reimbursed at the following rate: Initial and Subsequent Reports – Not to exceed \$10.00 for reports twenty (20) pages or less in length, and twenty-five (25) cents per page after the first twenty pages. Under no circumstances shall a provider bill for more than one report per visit. Initial reports shall be billed using procedure code WC101, subsequent reports shall be billed using procedure code WC102, and final reports shall be billed using procedure code WC103.
- (5) A medical provider shall not charge any fee for completing a medical report form required by the Division.

PROPOSED RULES

Authority: T.C.A. §§50-6-204, 50-6-205 (Supp. 2004), 50-6-233 (Repl. 1999).

0800-2-17-.16 ADDITIONAL REPORTS

Nothing in this rule shall preclude a carrier or an employee from requesting reports from a provider in addition to those specified in Rule 0800-2-17-.15.

Authority: T.C.A. §§50-6-204, 50-6-205 (Supp. 2004), 50-6-233 (Repl. 1999).

0800-2-17-.17 DEPOSITION/WITNESS FEE LIMITATION

- (1) Any provider who gives a deposition shall be allowed a witness fee.
- (2) Procedure Code 99075 must be used to bill for a deposition.
- (3) Licensed physicians shall be reimbursed for depositions at the same rate established in Rule 0800-2-16-.01

Authority: T.C.A. §§50-6-204, 50-6-205 (Supp. 2004), 50-6-233 (Repl. 1999).

0800-2-17-.18 OUT-OF-STATE PROVIDERS

All services and requests for change-of-physician to out-of-state providers must be made to providers who agree to abide by the Division's Medical Fee Schedule Rules, In-patient Hospital Fee Schedule Rules and Medical Cost Containment Program Rules.

Authority: T.C.A. §§50-6-204, 50-6-205 (Supp. 2004).

0800-2-17-.19 PREAUTHORIZATION

Preauthorization shall be required for all non-emergency hospitalizations, non-emergency transfers between facilities, and non-emergency outpatient services. Decisions regarding authorization must be communicated to the requesting provider within seven (7) business days. Failure to provide a timely decision within seven (7) business days shall result in the authorization being deemed approved. Any decision of denial for payment for any type of health care service and/or treatment resulting from a utilization review, as opposed to a determination of whether such service or treatment is related to a compensable injury or occupational disease, shall only be made by an agent of a Utilization Review Company properly approved by the Tennessee Department of Commerce and Insurance as prescribed in Rule 0800-2-6-.02. Upon emergency admission, notice must be given to the carrier within 24 hours or the next business day.

Authority: T.C.A. §§50-6-118, 50-6-125, 50-6-128, 50-6-204, 50-6-205 (Supp. 2004).

0800-2-17-.20 PROCESS FOR RESOLVING DIFFERENCES BETWEEN CARRIERS AND PROVIDERS REGARDING BILLS

- (1) Carrier's Dispute of a Bill
 - (a) When a carrier adjusts and/or disputes a bill or portion thereof, the carrier shall notify the provider within thirty-one (31) calendar days of the receipt of the bill of the specific reasons

PROPOSED RULES

for adjusting and/or disputing the bill or portion thereof, and shall notify the provider of its right to provide additional information and to request reconsideration of the carrier's action.

- (b) If the provider sends a bill to a carrier and the carrier does not respond in thirty-one (31) calendar days, and if a provider sends a second bill and receives no response within 62 days from the date the provider supplied the first bill, the provider may then proceed with whatever collection actions it deems appropriate in a court of law with proper jurisdiction.
 - (c) The carrier shall notify the employer, employee and the provider that the rules prohibit a provider from billing an employee, employer, or carrier for any amount for health care services provided for the treatment of a compensable work-related injury, illness or occupational disease when that amount is disputed by the carrier pursuant to its utilization review program, or when the amount exceeds the maximum allowable payment established by the Fee Schedule Rules (Medical and In-patient Hospital). The carrier shall request the employee to notify the carrier if the provider so bills the employee, or employer.
- (2) Provider's Request for Reconsideration of Bill
- (a) A provider may request reconsideration of its adjusted and/or disputed bill by a carrier within thirty-one (31) days of receipt of a notice of an adjusted and/or disputed bill or portion thereof. The provider's request to the carrier for reconsideration of the adjusted and/or disputed bill shall include a statement in detail of the reasons for disagreement with the carrier's adjustment and/or dispute of a bill or portion thereof.
- (3) Carrier's Response to Provider's Request for Reconsideration of Bill; Provider's Right to Appeal
- (a) Within thirty-one (31) calendar days of receipt of a provider's request for reconsideration, the carrier shall notify the provider of the actions taken and a detailed statement of the reasons. The carrier's notification shall include an explanation of the appeal process provided under this rule.
 - (b) If a provider is disagrees with the action taken by the carrier on its request for reconsideration, the provider may file a request for Administrative Review within thirty-one (31) calendar days from the date of receipt of a carrier's denial of the provider's request for reconsideration, and the provider shall supply a copy to the carrier.
 - (c) If within sixty-two (62) calendar days of the provider's request for reconsideration, the provider does not receive payment for the adjusted and/or disputed bill or portion thereof, or a written detailed statement of the reasons for the actions taken by the carrier, then the provider may make application for Administrative Review by the Medical MCCCC.
- (4) Disputes
- (a) Unresolved disputes between a carrier and provider concerning charges and/or due to conflicting interpretation of these Rules and/or the Medical Fee Schedule Rules and/or the In-patient Hospital Fee Schedule Rules may be presented to the Medical Care and Cost Containment Committee. A request for Administrative Review may be submitted to:

PROPOSED RULES

Medical Director of the Workers' Compensation Division,
Tennessee Department of Labor and Workforce Development
710 James Robertson Parkway, Andrew Johnson Tower, 2nd Floor
Nashville, Tennessee 37243.

- (b) Valid requests for Administrative Review do not require a particular form but must be legible and contain copies of the following:
 - 1. Copies of the original and resubmitted bills in dispute which include dates of service, procedure codes, charges for services rendered and any payment received, and an explanation of unusual services or circumstances.
 - 2. Copies of the specific reimbursement.
 - 3. Supporting documentation and correspondence, if any.
 - 4. Specific information regarding contact with the carriers.
 - 5. A verified or declared written medical report signed by the physician.
 - 6. A specific written request for Administrative Review.
- (c) The party requesting Administrative Review must send a copy of the request and all documentation accompanying the request to the opposing party as well.

Authority: T.C.A. §§50-6-126, 50-6-204, 50-6-205 (Supp. 2004), 50-6-226, 50-6-233 (Repl. 1999).

0800-2-17-.21 ADMINISTRATIVE REVIEW OF FEE SCHEDULE DISPUTES/HEARINGS

- (1) Administrative Review Procedure
 - (a) When a request for Administrative Review by the MCCCC is received by the Division's Medical Director, the parties will be notified when the MCCCC will consider the dispute.
 - (b) The MCCCC shall consider the dispute and issue its recommendation as to the proper resolution of the dispute.
 - (c) If the parties to the dispute do not follow the recommendation of the MCCCC, then either party may proceed in any court of law with proper jurisdiction to decide the dispute.
- (2) Computation of Time Periods In computing a period of time prescribed or allowed by the Medical Fee Schedule Rules, Medical Cost Containment Program Rules and In-Patient Hospital Fee Schedule Rules, the day of the act, event or default from which the designated period of time begins to run shall not be included. The last day on which compliance therewith is required shall be included. If the last day within which an act shall be performed or an appeal filed is a Saturday, Sunday, or a legal holiday, the day shall be excluded, and the period shall run until the end of the next day which is not a Saturday, Sunday, or legal holiday. ["Legal holiday" means those days designated as a holiday by the President or Congress of the United States or so designated by the laws of this State.]

Authority: T.C.A. §§50-6-204, 50-6-205 (Supp. 2004), 50-6-233 (Repl. 1999).

PROPOSED RULES

0800-2-17-.22 UTILIZATION REVIEW

- (1) Scope of this part:
 - (a) Requirements contained in this part shall pertain to utilization review activity as defined by T.C.A. §§ 50-6-124 (Repl. 1999) with respect to services by a provider for health care or health related services furnished as a result of a compensable injury, illness or occupational disease arising out of and in the course of employment. These Rules are intended to supplement and do not in any way displace the Division's Utilization Review Rules, Chapter 0800-2-6.
- (2) Carrier's Utilization Review Program
 - (a) The carrier shall have a utilization review program.
 - (b) Utilization review shall be conducted in a reasonable manner and in accordance with this rule.
 - (c) Under the utilization review program, the carrier shall do all of the following:
 1. Perform ongoing utilization review of medical bills to identify over-utilization of services and improper billing;
 2. Determine the accuracy of the procedure coding. If the carrier determines, based upon review of the bill and any related material which describes the procedure performed, that the procedure is incorrectly or incompletely coded, the carrier may recode the procedure, but shall notify the provider of the reasons for the recoding within 30 days of receipt of the bill;
 3. Reduce the bill to the maximum allowable payment for that procedure;
 4. Refer to the Division's Medical Director all providers whose billing practices indicate over-utilization.
 5. A carrier may have another certified entity perform utilization review activities on its behalf.
 - (d) The utilization review program, whether operated by the carrier or an entity on behalf of the carrier, shall be certified by the Tennessee Department of Commerce and Insurance as prescribed in the Division's Rule 0800-2-6-.02.
 - (e) The carrier shall provide the Division with the name, address, and license number (and a copy of the contract agreement between the carrier and other entity if applicable) of the entity responsible for conducting the carrier's utilization review program.
 - (f) The carrier is responsible for notifying the Division when changing reviewing entities.
 - (g) For purposes of this rule, a carrier which has another entity perform utilization review activities on its behalf maintains full responsibility for compliance with this rule.
 - (h) Under the carrier's utilization review program, the carrier shall make determinations concerning a compensable injury, illness or occupational disease through one of the following approaches:

PROPOSED RULES

1. Review by licensed, registered, or certified health care professionals.
2. The application of criteria developed by licensed, registered, or certified health care professionals.
3. A combination of approaches in subdivisions (1) and (2) of this subsection according to the type of covered injury or illness.
 - (i) Licensed, registered, or certified health care professionals shall be involved in determining the carrier's response to a request by a provider for reconsideration of its bill.
 - (j) These licensed, registered, or certified health care professionals shall have suitable occupational injury or disease expertise, or both, to render an informed clinical judgment on the medical appropriateness of the services provided.

Authority: T.C.A. §§50-6-124, 50-6-204, 50-6-205 (Supp. 2004), 50-6-233 (Repl. 1999).

0800-2-17-.23 RULE REVIEW

The Division encourages participation in the development of and changes to the Medical Cost Containment Program Rules, the Medical Fee Schedule Rules and the In-patient Hospital Fee Schedule Rules by all groups, associations, and the public. Any such group, association or other party desiring input into or changes made to these Rules and associated schedules must make their recommendations, in writing, to the Commissioner. After analysis, the Division may incorporate such recommended changes into Rules after appropriate consideration and public comment. The Medical Fee Schedule Rules, Medical Cost Containment Program Rules and In-Patient Hospital Fee Schedule Rules shall be reviewed by the Commissioner, in consultation with the Medical Care and Cost Containment Committee and the Advisory Council on Workers' Compensation, July 2006 and on an annual basis thereafter. When appropriate, the Commissioner may revise these Rules as necessary and appropriate.

Authority: T.C.A. §§ 50-6-204 (Supp. 2004).

0800-2-17-.24 PROVIDER AND FACILITY FEES FOR COPIES OF MEDICAL RECORDS

- (1) Health care providers and facilities are entitled to recover a reasonable amount to cover the cost of copying documents requested by the carrier, self-insured employer, employee, attorneys, etc. Documentation which is submitted by the provider and/or facility, but was not specifically requested by the carrier, shall not be allowed a copy charge.
- (2) Health care providers and facilities must furnish an injured employee or the employee's attorney and carriers/self-insureds or their legal representatives copies of records and reports upon request. The maximum charge allowed shall be the same as that set out in T.C.A. §§ 50-6-204, as amended.
- (3) Health care providers and facilities may charge the actual direct cost of copying x-rays, microfilm or other non-paper records.
- (4) The copying charge shall be paid by the party who requests the records.

PROPOSED RULES

(5) An itemized invoice shall accompany the copy.

Authority: T.C.A. §§50-6-204, 50-6-205 (Supp. 2004), 50-6-233 (Repl. 1999).

0800-2-17-.25 PENALTIES FOR VIOLATIONS OF FEE SCHEDULE RULES AND MEDICAL COST CONTAINMENT PROGRAM RULES

The Commissioner, Commissioner's Designee, or an agency member appointed by the Commissioner, shall have the authority to assess civil penalties up to and including \$10,000.00 per violation, as set forth more fully in Rule 0800-2-17-.13, for violations of the Medical Fee Schedule Rules, In-patient Hospital Fee Schedule Rules or the Medical Cost Containment Program Rules.

Authority: T.C.A. §§50-6-118, 50-6-125, 50-6-128, 50-6-204, 50-6-205 (Supp. 2004), 50-6-233 (Repl. 1999).

The proposed rules set out herein were properly filed in the Department of State on the 9th day of May, 2005, and pursuant to the instructions set out above, and in the absence of the filing of an appropriate petition calling for a rulemaking hearing, will become effective on the 28th day of September, 2005. (05-07)

PROPOSED RULES

THE TENNESSEE DEPARTMENT OF LABOR AND WORKFORCE DEVELOPMENT - 0800 DIVISION OF WORKERS' COMPENSATION

CHAPTER 0800-2-18 MEDICAL FEE SCHEDULE

Presented herein are proposed rules of the Tennessee Department of Labor and Workforce Development submitted pursuant to T.C.A. Section 4-5-202 in lieu of a rulemaking hearing. It is the intent of the Tennessee Department of Labor and Workforce Development to promulgate these rules without a rulemaking hearing unless a petition requesting such hearing is filed within thirty (30) days of the publication date of the issue of the Tennessee Administrative Register in which the proposed rules are published. Such petition, to be effective, must be filed with the Workers' Compensation Division, Second Floor of the Andrew Johnson Tower located at 710 James Robertson Parkway, Nashville, TN 37243-0661 and in the Department of State, Eighth Floor, Tennessee Tower, William Snodgrass Building, 312 8th Avenue North, Nashville, TN 37243, and must be signed by twenty-five (25) persons who will be affected by the rule, or submitted by a municipality which will be affected by the rules, or an association of twenty-five (25) or more members, or any standing committee of the General Assembly.

For a copy of these proposed rules, contact: Vickie Gregory, Administrative Secretary, Tennessee Department of Labor and Workforce Development, Division of Workers' Compensation, Andrew Johnson Tower, Second Floor, 710 James Robertson Parkway, Nashville, TN 37243-0661, (615) 253-1613.

NEW RULES

TABLE OF CONTENTS

0800-2-18-.01 Medicare-basis for System, Applicability, Effective Date and Coding References	0800-2-18-.08 Chiropractic Services Guidelines
0800-2-18-.02 General Information and Instructions for Use	0800-2-18-.09 Physical and Occupational Therapy Guidelines
0800-2-18-.03 General Guidelines	0800-2-18-.10 Durable Medical Equipment (DME) Guidelines
0800-2-18-.04 Surgery Guidelines	0800-2-18-.11 Orthotics, Prosthetics and Implants Guidelines
0800-2-18-.05 Anesthesia Guidelines	0800-2-18-.12 Pharmacy Schedule Guidelines
0800-2-18-.06 Injections Guidelines	0800-2-18-.13 Ambulance Services Guidelines
0800-2-18-.07 Ambulatory Surgical Centers and Outpatient Hospital Care (Including Emergency Room Facility Charges)	0800-2-18-.14 Clinical Psychological Service Guidelines
	0800-2-18-.15 Penalties for Violations of Fee Schedules

0800-2-18-.01 MEDICARE-BASIS FOR SYSTEM, APPLICABILITY, EFFECTIVE DATE AND CODING REFERENCES

- (1) The Medical Fee Schedule of the Tennessee Division of Workers' Compensation ("TDWC") is a Medicare-based system, but with multiple conversion factors. Only one geographical practice index is recognized in Tennessee under Medicare, therefore these Medical Fee Schedule rates apply state-wide. The Medical Fee Schedule is based upon the Centers for Medicare and Medicaid Services ("CMS") (formerly the Health Care Financing Administration's) ("HCFA") Medicare Resource Based Relative Value Scale ("RBRVS"), utilizing CMS' national relative value units and Tennessee specific conversion factors adopted by the Tennessee Division of Workers' Compensation. Anyone using this schedule must consult and be familiar with the Division's Medical Cost Containment Program rules, 0800-2-17-.01 et seq., the In-patient Hospital Fee Schedule

PROPOSED RULES

rules, 0800-2-19.01 et seq., the most current American Medical Association (“AMA”) CPT Codes, Health Care Financing Administration Common Procedure Coding System (“HCPCS”), American Society of Anesthesiologists (“ASA”) Relative Value Guide, and the most current effective Medicare procedures and guidelines.

- (2) This Medical Fee Schedule must be used in conjunction with Medical Cost Containment Program Rules and the In-patient Hospital Fee Schedule Rules. The definitions set out in those rules, as well as the other general provisions, including but not limited to those regarding prompt payment of provider’s bills, are adopted by reference as if set forth fully herein and those Rules must be used in conjunction with these Medical Fee Schedule Rules.
- (3) The Medical Fee Schedule Rules are effective July 1, 2005 and apply to all services provided on or after July 1, 2005. The most current versions of the American Medical Association’s CPT and the Medicare RBRVS shall automatically be applicable and are adopted by these Rules by reference upon their effective dates. Fees shall be calculated using the edition of the CPT and RBRVS effective on the date of service.

Authority: T.C.A. §§ 50-6-204, 50-6-205 (Supp. 2004), 50-6-233 (Repl. 1999).

0800-2-18-.02. GENERAL INFORMATION AND INSTRUCTIONS FOR USE

- (1) Format

This schedule consists of the following sections: General Medicine (including Evaluation and Management), General Surgery, Neuro- and Orthopedic Surgery, Radiology, Pathology, Anesthesiology, Injections, Durable Medical Equipment, Implants and Orthotics, Pharmacy, Physical and Occupational Therapy, Ambulatory Surgical Centers and Outpatient Hospital Care, Chiropractic, Ambulance Services and Clinical Psychological Services. Providers should use the section(s) containing the procedure(s) they perform, or the service(s) they render.

- (2) Reimbursement

- (a) Unless otherwise indicated herein, the most current Medicare procedures and guidelines are hereby adopted and incorporated as part of these Rules as if fully set out herein and effective upon adoption and implementation by the CMS. Whenever there is no specific fee or methodology for reimbursement set forth in these Rules for a service, diagnostic procedure, equipment, etc., then the amount of reimbursement shall be at 100% of the most current effective CMS’ Medicare allowable amount. The most current effective Medicare guidelines and procedures shall be followed in arriving at the correct amount. For purposes of these Rules, the Medicare amount may be adjusted upward annually based upon the annual Medicare Economic Index adjustment, but this amount shall never fall below the effective 2005 Medicare amount. Whenever there is no applicable Medicare code or method of reimbursement, the service, equipment, diagnostic procedure, etc. shall be reimbursed at the lesser of the usual and customary amount, or the prevailing charge amount, and shall be billed By Report (“BR”).

- (b) Reimbursement to all providers shall be the lesser of the following:

1. The provider’s usual charge;

PROPOSED RULES

2. The fee calculated according to the TDWC Fee Schedule Rules (includes 100% of Medicare if no other specific fee or methodology is set forth in these Rules);
3. The MCO/PPO or any other contracted price;
4. In no event shall reimbursement be in excess of these TDWC Fee Schedules, unless otherwise provided in the Division’s rules. Reimbursement in excess of the TDWC Medical Fee Schedule may result in civil penalties, at the Commissioner’s discretion, of \$10,000.00 per violation for each violation assessed severally against the provider accepting such fee and the carrier or employer paying the excessive fee, should a pattern or practice of such activity be found. At the Commissioner’s discretion, such provider may also be reported to the appropriate certifying board or other appropriate authority, and may be subject to exclusion from participating further in providing care under the Tennessee Workers’ Compensation Act (“Act”).

(3) Fee Schedule Calculations

- (a) The TDWC Medical Fee Schedule amount can be calculated for any specific CPT code by multiplying the national “transitioned nonfacility total relative value units” (“RVUs”) by the conversion factor applicable to that *CPT*. Certain areas listed below do not have a conversion factor and the maximum reimbursement amount allowed is the usual and customary amount, as indicated. Other areas not listed below, such as dentistry, have a maximum reimbursement amount of 100% of the Medicare allowable amount calculated in accordance with then current effective Medicare guidelines and methodology.

(4) Conversion Factors—based on the CMS’ 2005 Tennessee unit amount of 37.8975

- (a) The conversion factors applicable under this Medical Fee Schedule are:

<u>Conversion Factor</u>	<u>As a percent of TN Medicare Rate</u>	
Anesthesiology.....	Usual and Customary Amount	
Chiropractic Care.....	\$49.27	130%
General Surgery.....	\$75.80	200%
Home Health Care.....	100% of LUPA*	
Home Infusion.....	Usual and Customary Amount	
Gen. Medicine (includes unlisted specialties, Evaluation & Management, etc.)		
Office visits, E&M, etc. CPT codes	\$60.64	160%
Emergency care CPT codes	\$75.80	200%
Neurosurgery (board-eligible or certified physicians) (Non-board eligible physicians paid general surgery rate)	\$104.14	275%
Orthopedic Surg. (board-eligible or cert. physicians) (Non-board eligible physicians paid general surgery rate)	\$104.14	275%

PROPOSED RULES

0800-2-18-.03 GENERAL GUIDELINES

- (1) Guidelines define items that are necessary to appropriately interpret and report the procedures and services contained in a particular section and provide explanations regarding terms that apply only to a particular section.
- (2) The Guidelines found in the most current edition of the AMA's CPT apply to the following: General Medicine (includes Evaluation and Management), General Surgery, Neuro-surgery, Orthopedic Surgery, Chiropractic, Physical and Occupational Therapy, Home Health Care, Home Infusion, Ambulatory Surgical Centers and Outpatient Hospital Services, Radiology, Clinical Psychological, and Pathology. CDT-3 Codes of current dental terminology prescribed by the American Dental Association, including the terminology updates and revision issued in the future by the American Dental Association shall be used for all Dentistry services.
- (3) In addition to the Guidelines found in the AMA's CPT, the following Division's Guidelines also apply. Whenever a conflict exists between these Medical Fee Schedule Rules and any other fee schedule, rule or regulation, these Medical Fee Schedule Rules shall govern.

Authority: T.C.A. §§ 50-6-204, 50-6-205 (Supp. 2004), 50-6-233 (Repl. 1999).

0800-2-18-.04 SURGERY GUIDELINES

- (1) Multiple Procedures: Reimbursement shall be based on 100% of the physician's usual charge for the major procedure (not to exceed 100% of the TDWC Medical Fee Schedule amount allowable) plus 50% of the physician's usual charge for the lesser or secondary procedure (s) (not to exceed 50% of the TDWC Medical Fee Schedule allowable).
- (2) Services Rendered by More Than One Physician:
 - (a) Concurrent Care: One attending physician shall be in charge of the care of the injured employee. However, if the nature of the injury requires the concurrent services of two or more specialists for treatment, then each physician shall be entitled to the listed fee for services rendered.
 - (b) Surgical Assistant: A physician who assists at surgery may be reimbursed as a surgical assistant. To identify surgical assistant services provided by physicians, Modifier 80 or 81 shall be added to the surgical procedure code which is billed. A physician serving as a surgical assistant must submit a copy of the operative report to substantiate the services rendered. Reimbursement is limited to the lesser of the surgical assistant's usual charge or 20% of the maximum allowable Medical Fee Schedule amount. Duly licensed physician assistants may serve as surgical assistants as deemed appropriate by the physician, and if so, the licensed physician assistants' reimbursement shall not exceed the physician assistant fee due for the procedure as calculated pursuant to Medicare guidelines, not the conversion factors contained in the workers' compensation Medical Fee Schedule.
 - (c) Two Surgeons: For reporting see the most current CPT. Each surgeon must submit an operative report documenting the specific surgical procedure(s) provided. Each surgeon must submit an individual bill for the services rendered. Reimbursement must not be made

PROPOSED RULES

to either surgeon until the carrier has received each surgeon's individual operative report and bill. Reimbursement to both surgeons shall not exceed 150% of the maximum allowable Fee Schedule amount of the first surgeon and shall be allocated between the surgeons as agreed by them.

- (3) When a surgical fee is chargeable, no office visit charge shall be allowed for the day on which this surgical fee is earned, except if surgery is performed on the same day as the physician's first examination. All exceptions require use of the appropriate modifiers and shall be filed BR.
- (4) Certain of the listed procedures in the Medical Fee Schedule are commonly carried out as an integral part of a total service and, as such, do not warrant a separate charge.
- (5) Lacerations ordinarily require no aftercare except removal of sutures. The removal is considered a routine part of an office or hospital visit and shall not be billed separately unless such sutures are removed by a provider different from the provider administering the sutures.

Authority: T.C.A. §§ 50-6-204, 50-6-205 (Supp. 2004), 50-6-233 (Repl. 1999).

0800-2-18-.05 ANESTHESIA GUIDELINES

- (1) General Information and Instructions.
 - (a) The current ASA Relative Value Guide, by the American Society of Anesthesiologists will be used to determine reimbursement for anesthesia codes that do not appear in the RBRVS. These values are to be used only when the anesthesia is personally administered by an Anesthesiologist or Certified Registered Nurse Anesthetist ("CRNA") who remains in constant attendance during the procedure, for the sole purpose of rendering such anesthesia service. To order the Relative Value Guide, write to the American Society of Anesthesiologists, 520 N Northwest Highway; Park Ridge, IL 60068-2573, or call (847) 825-5586.
 - (b) When anesthesia is administered by a CRNA not under the medical direction of an anesthesiologist, reimbursement shall be 90% of the provider's usual and customary charge. No payment will be made to the surgeon supervising the CRNA.
 - (c) When anesthesia is administered personally by an anesthesiologist or administered by a care team involving an anesthesiologist and CRNA, reimbursement shall not exceed 100% of the provider's usual and customary charge.
- (2) Anesthesia Values
 - (a) Each anesthesia service contains two value components which make up the charge and determine reimbursement: a Basic Value and a Time Value.
 - (b) Basic Value: This relates to the complexity of the service and includes the value of all usual anesthesia services except the time actually spent in anesthesia care and any modifiers. The Basic Value includes usual preoperative and postoperative visits, the anesthesia care during the procedure, the administration of fluids and/or blood products incidental to the anesthesia or surgery and interpretation of non-invasive monitoring (ECG, temperature,

PROPOSED RULES

blood pressure, oximetry, capnography, and mass spectrometry). When multiple surgical procedures are performed during an operative session, the **Basic Value** for anesthesia is the Basic Value for the procedure with the highest unit value. The Basic Values in units for each anesthesia procedure code are listed in the current ASA Relative Value Guide.

- (c) Time Value: Anesthesia time starts when the anesthesiologist or CRNA begins to prepare the patient for induction of anesthesia and ends when the personal attendance of the anesthesiologist or CRNA is no longer required and the patient can be safely placed under customary, postoperative supervision. Anesthesia time must be reported on the claim form as the total number of minutes of anesthesia. For example, one hour and eleven minutes equals 71 minutes of anesthesia. The Time Value is converted into units for reimbursement as follows:
 - 1. Each 15 minutes or any fraction thereof equals one (1) time unit. For example, 71 minutes of anesthesia time would have the following time units: $71/15 = 5$ Time Units.
 - 2. No additional time units are allowed for recovery room observation monitoring after the patient can be safely placed under customary post-operative supervision.
- (3) Total Anesthesia Value
 - (a) The total anesthesia value ("TAV") for an anesthesia service is the sum of the Basic Value (units) plus the Time Value which has been converted into units. The TAV is calculated for the purpose of determining reimbursement.
- (4) Billing
 - (a) Anesthesia services must be reported by entering the appropriate anesthesia procedure code and descriptor into Element 24 D of the HCFA 1500 Form. The provider's usual total charge for the anesthesia service must be entered in Element 24 F on the HCFA 1500 Form. The total time in minutes must be entered in Element 24 G of the HCFA 1500 Form.
- (5) Reimbursement
 - (a) Reimbursement for anesthesia services must be no more than the provider's usual and customary charge.
- (6) Medical Direction Provided by Anesthesiologists
 - (a) When an anesthesiologist is not personally administering the anesthesia but is providing medical direction for the services of a nurse anesthetist who is not employed by the anesthesiologist, the anesthesiologist may bill for the medical direction. Medical direction includes the pre and post-operative evaluation of the patient. The anesthesiologist must remain within the operating suite, including the pre-anesthesia and post-anesthesia recovery areas, except in extreme emergency situations. Reimbursement shall not exceed 100% of the provider's usual and customary charge.
- (7) Anesthesia by Surgeon

PROPOSED RULES

- (a) Local Anesthesia
 - 1. When infiltration, digital block or topical anesthesia is administered by the operating surgeon or surgeon's assistant, reimbursement for the procedure and anesthesia are included in the global reimbursement for the procedure.
- (b) Regional or General Anesthesia
 - 1. When regional or general anesthesia is provided by the operating surgeon or surgeon's assistant, the surgeon may be reimbursed for the anesthesia service in addition to the surgical procedure.
 - (i) To identify the anesthesia service, list the CPT surgical procedure code and add Modifier 47.
 - (ii) Reimbursement shall not exceed the provider's usual and customary charge.
 - (iii) The operating surgeon must not use the diagnostic or therapeutic nerve block codes to bill for administering regional anesthesia for a surgical procedure.
- (8) Unlisted Service, Procedure or Unit Value. When an unlisted service or procedure is provided or without specified unit values, the values used shall be substantiated BR.
- (9) Procedures Listed In The ASA Relative Value Guide Without Specified Unit Values. For any procedure or service that is unlisted or without specified unit value, the physician or anesthetist shall establish a unit value consistent in relativity with other unit values shown in the current ASA Relative Value Guide. Pertinent information concerning the nature, extent and need for the procedure or service, the time, the skill and equipment necessary, etc., shall be furnished. Sufficient information shall be furnished to identify the problem and the service(s).
- (10) Actual time of beginning and duration of anesthesia time may require documentation, such as a copy of the anesthesia record in the hospital file.
- (11) Special Supplies. Supplies and materials provided by the physician over and above those usually included with the office visit or other services rendered may be listed separately. Drugs, materials provided, and tray supplies shall be listed separately. Supplies and materials provided in a hospital or other facility must not be billed separately by the physician or CRNA. These charges must be billed by the hospital.
- (12) Separate or Multiple Procedures. It is appropriate to designate multiple procedures that are rendered on the same date by separate entries.

Authority: T.C.A. §§ 50-6-204, 50-6-205 (Supp. 2004), 50-6-233 (Repl. 1999).

0800-2-18-.06 INJECTIONS GUIDELINES

Reimbursement for injection(s) (such as J codes) includes allowance for CPT code 90782 in addition to average wholesale price of each drug. In cases where multiple drugs are given as one injection, only one administration fee is owed. Surgery procedure codes defined as injections include the administration portion of payment for the medications billed. J Codes are found in the Health Care Financing Administration Common Procedure Coding System ("HCPCS").

PROPOSED RULES

Authority: T.C.A. §§ 50-6-204, 50-6-205 (Supp. 2004), 50-6-233 (Repl. 1999).

0800-2-18-.07 AMBULATORY SURGICAL CENTERS AND OUTPATIENT HOSPITAL CARE (INCLUDING EMERGENCY ROOM FACILITY CHARGES)

- (1) When medically appropriate, surgical procedures may be performed on an outpatient basis to reduce unnecessary hospitalization and to shift care to a less costly setting.
- (2) For the purpose of the TDWC Medical Fee Schedule, “ambulatory surgical center” (“ASC”) means an establishment with an organized medical staff of physicians; with permanent facilities that are equipped and operated primarily for the purpose of performing surgical procedures, with continuous physicians and registered nurses on site or on call; which provides services and accommodations for patients to recover for a period not to exceed twenty-three (23) hours after surgery. An ambulatory surgical center may be a free standing facility or may be attached to a hospital facility. For purposes of workers’ compensation reimbursement to ASCs, the facility must be an approved Medicare ASC.
- (3) The CMS has implemented a prospective payment system (“PPS”) under Medicare for hospital outpatient services. All services paid under the new PPS are classified into groups called Ambulatory Payment Classifications (“APC”). Services in each APC are similar clinically and in terms of the resources they require. The CMS has established a payment rate for each APC.
- (4) The most current Medicare APC rates shall be used as the basis for facility fees charged for services provided in an ambulatory surgical center (“ASC”) and shall be reimbursed at a maximum of 150% of current value for such services at ASCs. Depending on the services provided, ASCs may be paid for more than one APC for an encounter. When multiple procedures are performed during the same surgical session, the reimbursement shall be made at 100% of the appropriate rate for the highest charge procedure and 50% of the appropriate rate for all additional procedures. Only separate and distinct surgical procedures shall be billed. When applicable, the Medicare Guidelines shall be used in determining separate and distinct surgical procedures.
- (5) All other outpatient hospital care, including but not limited to observation and emergency room facility fees, shall be calculated in accordance with the most current Medicare rules and procedures applicable to such service and shall be reimbursed at a maximum rate of 150% of the current value of Medicare reimbursement for outpatient hospital care.
- (6) Facility services do not include (the following services may be billed separately from the facility fees):
 - (a) Physician services
 - (b) Laboratory services
 - (c) X-rays
 - (d) Diagnostic procedures not related to the surgical procedure
 - (e) Prosthetic devices

PROPOSED RULES

- (f) Ambulance services
 - (g) Orthotics
 - (h) Implantables
 - (i) DME for use in the patient's home
 - (j) CRNA or Anesthesia Physician Services (supervision of CRNA is included in the facility)
 - (k) Take home medications
 - (l) Take home supplies
- (7) The above list of services and supplies shall be reimbursed according to the TDWC Fee Schedule Rules or at the usual and customary charge (for items not listed in the fee schedule rules).
- (8) There may be occasions in which the patient was scheduled for out patient surgery and it becomes necessary to admit the patient. All ambulatory patients who are admitted to the hospital and stay longer than 23 hours past ambulatory surgery will be paid according to the Inpatient Hospital Fee Schedule Rules, 0800-2-19.01 et seq.
- (9) Pre-admission lab and x-ray may be billed separately from the Ambulatory Surgery bill when performed 24 hours or more prior to admission, and will be reimbursed the lesser of billed charges or the payment limit of the fee schedule. Pre-admission lab and radiology are not included in the facility fee.
- (10) Facility fees for surgical procedures not listed shall be reimbursed BR at the usual and customary rate.

Authority: T.C.A. §§ 50-6-204, 50-6-205 (Supp. 2004), 50-6-233 (Repl. 1999).

0800-2-18-.08 CHIROPRACTIC SERVICES GUIDELINES

- (1) Charges for chiropractic services shall not exceed 130% of the participating fees prescribed in the Medicare RBRVS System fee schedule. The number of approved visits shall be limited pursuant to any restrictions in T.C.A. 50-6-204. The same procedures for certification applicable to physical therapy and occupational therapy services under Rule 0800-2-18-.09(5) below apply to chiropractic services (such as UR review after 12 visits), except that the thirty (30) time period therein shall not apply to chiropractic services.
- (2) For chiropractic services, an office visit shall not be billed on the same day as a manipulation is billed.
- (3) If allowable payment for chiropractic services is not paid by employers or insurers for chiropractic services provided to employees who have suffered a compensable work-related injury under the Workers' Compensation Law within thirty-one (31) days from the date of receipt by the employer or insurer of the bill for chiropractic services provided to such an employee, interest at the rate of 25% per annum of the payment allowed pursuant to these rules, compounded monthly, may be

PROPOSED RULES

charged and paid as set forth in Rule 0800-2-11-.10 of the Medical Cost Containment Program Rules.

- (4) There shall be no fee allowable for any modalities performed in excess of four (4) modalities per day per employee. The Medicare definition of modality is applicable.
- (5) There shall be no charge for either hot packs or cold packs provided to an employee who has suffered a compensable work-related injury under the Workers' Compensation Law.

Authority: T.C.A. §§ 50-6-204, 50-6-205 (Supp. 2004), 50-6-233 (Repl. 1999).

0800-2-18-.09 PHYSICAL AND OCCUPATIONAL THERAPY GUIDELINES

- (1) Charges for physical and/or occupational therapy services shall be reimbursed on a bifurcated sliding scale based upon physician interest in the facility providing services. For the purpose of this Medical Fee Schedule, a "physician-affiliated" facility is one in which the referring physician has any type of financial interest, which includes, but is not limited to, any type of ownership, interest, debt, loan, lease, compensation, remuneration, discount, rebate, refund, dividend, distribution, subsidy, or other form of direct or indirect benefit of any kind, whether in money or otherwise, between the facility to whom the physician refers a person for services and that physician. Any hospital-based PT or OT facility shall also be deemed "physician-affiliated" if the referring physician is an employee of such hospital, or if he or she receives a benefit of any kind from the referral.
 - (a) Independently-owned and operated facilities' reimbursement shall not exceed one hundred fifty percent (150%) of the participating fees prescribed in the Medicare RBRVS System fee schedule (Medicare Fee Schedule) for the first six (6) visits, and shall not exceed one hundred thirty percent (130%) for visits 7 through 12. For all visits after visit 12, reimbursement shall not exceed one hundred percent (100%).
 - (b) Physician-affiliated facilities' reimbursement shall not exceed one hundred thirty percent (130%) of the participating fees prescribed in the Medicare RBRVS System fee schedule for the first six (6) visits, and shall not exceed one hundred five percent (105%) for visits 7 through 12. For all visits after visit 12, reimbursement shall not exceed one hundred percent (100%).
- (2) For physical therapy and/or occupational therapy, there shall be no charge for either hot packs or cold packs provided to an employee who has suffered a compensable work-related injury under the Workers' Compensation Law.
- (3) For physical therapy and/or occupational therapy, there shall be no fee allowable for any modalities performed in excess of four (4) modalities per day per employee. The Medicare definition of modality is applicable.
- (4) Any procedure for which an appropriate Medicare code is not available, such as a Functional Capacity Evaluation or work hardening, shall be billed BR. The lesser of the prevailing charge or the usual and customary charge shall be the maximum amount reimbursable for such services.
- (5) Whenever physical therapy and/or occupational therapy services exceed twelve (12) sessions/visits or a period over thirty (30) days, whichever comes first, then such treatment shall be reviewed pursuant to the carrier's utilization review program in accordance with the procedures set forth

PROPOSED RULES

in 0800-2-6 of the Division's Utilization Review rules before further physical therapy and/or occupational therapy services may be certified for payment by the carrier. Such certification shall be completed within two (2) business days of any request for certification to assure no interruption in delivery of needed services. Failure to properly certify such services as prescribed herein shall result in the forfeiture of any payment for uncertified services. The initial utilization review of physical therapy and/or occupational therapy services shall, if necessary and appropriate, certify an appropriate number of sessions/visits. If necessary, further subsequent utilization review shall be conducted to certify additional physical therapy and/or occupational therapy services as is appropriate.

Authority: T.C.A. §§ 50-6-204, 50-6-205 (Supp. 2004), 50-6-233 (Repl. 1999).

0800-2-18-.10 DURABLE MEDICAL EQUIPMENT GUIDELINES

- (1) All durable medical equipment shall be reimbursed at a maximum of the invoice amount plus the lesser of 15% of invoice or \$1,000.00, and coded using the HCPCS codes. Charges for durable medical equipment are in addition to, and shall be billed separately from, all facility and professional service fees. Supplies and equipment not addressed in this fee guideline shall be reimbursed at a reasonable amount, as defined in these Rules and coded 99070 if appropriate codes are not available in the HCPCS. All billing must contain the brand name, model number, and catalog number. Codes to be used are found in the HCPCS. Charges should be submitted on a HCFA 1500 form.
- (2) **Quality.** The reimbursement for supplies/equipment in this fee guideline is based on a presumption that the injured worker is being provided the highest quality of supplies/equipment. All billing must contain the brand name, model number, and catalog number.
- (3) **Rental/Purchase.** Rental fees are applicable in instances of short-term utilization (30-60 days). If it is more cost effective to purchase an item rather than rent it, this must be stressed and brought to the attention of the insurance carrier. The first month's rent should apply to the purchase price. However, if the decision to purchase an item is delayed by the insurance carrier, subsequent rental fees cannot be applied to the purchase price. When billing for rental, identify with modifier "RR".
- (4) **TENS Units.** All bills submitted to the carrier for Tens and Cranial Electrical Stimulator (CES) units should be accompanied by a copy of the invoice, if available.
 - (a) **Rentals**
 1. Include the following supplies:
 - (i) lead wires;
 - (ii) two (2) rechargeable batteries;
 - (iii) battery charger;
 - (iv) electrodes; and
 - (v) instruction manual and/or audio tape.

PROPOSED RULES

2. Supplies submitted for reimbursement must be itemized. In unusual circumstances where additional supplies are necessary, use modifier 22 and “**BR**”
3. Limited to 30 days trial period.

(b) Purchase:

1. Prior to the completion of the 30-day trial period, the prescribing doctor must submit a report documenting the medical justification for the continued use of the unit. The report should identify the following:
 - (i) Describe the condition and diagnosis that necessitates the use of a TENs unit.
 - (ii) Does the patient have any other implants which would affect the performance of the TENs unit or the implanted unit?
 - (iii) Was the TENs unit effective for pain control during the trial period?
 - (iv) Was the patient instructed on the proper use of the TENS unit during the trial period?
 - (v) How often does the patient use the TENS unit?
2. The purchase price should include the items below if not already included with the rental:
 - (i) lead wires;
 - (ii) two (2) rechargeable batteries; and
 - (iii) a battery charger.
3. Only the first month’s rental price shall be credited to purchase price.
4. Provider shall indicate TENs manufacturer, model name, and serial number.

(5) Continuous and Passive Motion (Use Code D0540)

Use of this unit in excess of 30 days requires documentation of medical necessity by the doctor. Only one (1) set of soft goods will be allowed for purchase.

Authority: T.C.A. §§ 50-6-204, 50-6-205 (Supp. 2004), 50-6-233 (Repl. 1999).

0800-2-18-.0-11 ORTHOTICS, PROSTHETICS AND IMPLANTS GUIDELINES

Implants, orthotics and prosthetics should be coded according to the HCFA Common Procedures Coding System (HCPCS). Copies may be obtained from the American Orthotic and Prosthetic Association, 1650 King Street, Suite 500, Alexandria, VA 22314, (703) 836-7116. Implants, orthotics and prosthetics shall be reimbursed at the supplier’s invoice amount, plus 15% of the invoice amount or \$1,000.00, whichever is less,

PROPOSED RULES

and coded using the HCPCS code. Charges for these items are in addition to, and shall be billed separately from, all facility and professional service fees. Supplies and equipment should be coded 99070 if appropriate codes are not available in the HCPCS. All billing must contain the brand name, model number, and catalog number. Charges should be submitted on a HCFA 1500 form.

Authority: T.C.A. §§ 50-6-204, 50-6-205 (Supp. 2004), 50-6-233 (Repl. 1999).

0800-2-18-.12 PHARMACY SCHEDULE GUIDELINES

- (1) The Pharmaceutical Fee Guideline Amount for prescribed drugs (medicines by pharmacists and dispensing practitioners) under the Tennessee workers' compensation laws is the lesser of:
 - (a) The provider's usual charge;
 - (b) A negotiated contract amount; or
 - (c) The fees established by the formula for brand-name and generic pharmaceuticals as described in subsection (5) of this section.
- (2) Prescribed Medication Services
 - (a) "Drug" has the meaning set out in T. C. A. § 63-10-204.
 - (b) Medicine or drugs may only be dispensed by a currently licensed pharmacist or a dispensing practitioner.
 - (c) Carriers may contract with pharmacy benefit managers to process and administer claims for reimbursement of pharmacy services and review the relatedness and appropriateness of prescribed services. Carriers and pharmacists may also negotiate alternative reimbursement schedules and amounts, so long as the reimbursement amount does not exceed the fee schedule amount set out in these Rules.
 - (d) For the purposes of these TWCD Medical Fee Schedule Rules, medicines are defined as drugs prescribed by an authorized health care provider and include only generic drugs or single-source patented drugs for which there is no generic equivalent, unless the authorized health care provider writes that the brand name is medically necessary and includes on the prescription "dispense as written."
- (3) Reimbursement
 - (a) The pharmaceutical reimbursement formula for prescribed drugs (medicines by pharmacists and dispensing practitioners) is the lesser of:

Average Wholesale Price* ("AWP") + \$5.10 filling fee, the provider's usual charge, or a negotiated contractual amount.

* The Commissioner may at any time adopt and implement a different base price other than AWP (such as average sales price), should medical reimbursement standards and/or local or other practices warrant, at the Commissioner's discretion.

PROPOSED RULES

- (b) Reimbursement to pharmacists must not exceed the amount calculated by the pharmaceutical reimbursement formula for prescribed drugs. A generic drug must be substituted for any brand name drug unless: 1) there is no pharmaceutical and bioequivalent drug available, or 2) the prescribing physician indicates that substitutions are prohibited by including the words "Dispense as Written", or "No Substitution Allowed" in the prescriber's own handwriting, along with a statement that the brand name drug is medically necessary. A prescribing physician may also prohibit substitution of generic drugs by oral or electronic communication to the pharmacist so long as the same content is conveyed that is required in a written prescription. A lower cost, therapeutically equivalent drug may be substituted for a prescribed drug if the requirements set out in Title 63, Chapter 10, Part 2 of Tennessee Code Annotated are all met.
1. A bill or receipt for a prescription drug shall include all of the following:
 - (i) When a brand name drug with a generic equivalent is dispensed, the brand name and the generic name shall be included unless the prescriber indicates "do not label."
 - (ii) If the drug has no brand name, the generic name, and the manufacturer's name or the supplier's name, shall be included, unless the prescriber indicates "do not label."
 - (iii) The strength, unless the prescriber indicates "do not label."
 - (iv) The quantity dispensed.
 - (v) The dosage.
 - (vi) The name, address, and federal tax ID# of the pharmacy.
 - (vii) The prescription number, if available.
 - (viii) The date dispensed.
 - (ix) The name of the prescriber.
 - (x) The name of the patient.
 - (xi) The price for which the drug was sold to the purchaser.
 - (xii) The National Drug Code Number ("NDC Number").
 2. The AWP shall be determined from the appropriate monthly publication. The monthly publication that shall be used for calculation shall be the same as the date of service. When an AWP is changed during the month, the provider shall still use the AWP from the monthly publication. The publications to be used are:
 - (i) Primary reference. *Price Alert* from First Data Bank.

PROPOSED RULES

- (ii) Secondary reference (for drugs NOT found in PriceAlert). Red Book from Medical Economics.
 - 3. Dietary supplements such as minerals and vitamins shall not be reimbursable unless a specific compensable dietary deficiency has been clinically established in the injured employee as a result of the work-related injury.
 - 4. A compounding fee not to exceed Twenty-five Dollars (\$25.00) per compound prescription may be charged if two (2) or more prescriptive drugs require compound preparation when sold by a hospital, pharmacy, or provider of service other than a physician.
 - 5. If allowable payment for prescriptive drugs is not paid by employers or carriers for prescriptions provided to employees who have suffered a compensable work-related injury under the Workers' Compensation Law within thirty-one (31) days from the date of receipt by the employer or insurer of the bill for prescriptive drugs provided to such an employee, interest at the rate of 2.08% /month of the payment allowed pursuant to these rules may be charged by a hospital, pharmacy, or provider of such service as set forth in Rule 0800-2-11-.10 of the Medical Cost Containment Program Rules.
 - 6. If a workers' compensation claimant chooses a brand-name medicine when a generic medicine is available and allowed by the prescriber, the claimant shall pay the difference in price between the brand-name and generic medicine and shall not be eligible to subsequently recover this difference in cost from the employer or carrier.
- (4) "Patent" or 'Proprietary Preparations"
- (a) "Patent" or "Proprietary preparations," frequently called "over-the-counter drugs," are sometimes prescribed for a work-related injury or illness instead of a legend drug.
 - (b) Generic substitution as discussed in (4)(b) above applies also to "over-the-counter" preparations.
 - (c) Pharmacists must bill and be reimbursed their usual and customary charge for the "over-the-counter" drug(s).
 - (d) The reimbursement formula does not apply to the "over-the-counter" drugs and no filling fee may be reimbursed.
- (5) Dispensing Practitioner
- (a) Dispensing practitioners shall be reimbursed the same as pharmacists for prescribed drugs (medicines), except such practitioners shall not receive a filling fee.
 - (b) "Patent" or "proprietary preparations" frequently called "over-the-counter drugs," dispensed by a physician(s) from their office(s) to a patient during an office visit should be billed as follows:
 - 1. Procedure Code 99070 must be used to bill for the "proprietary preparation" and the name of the preparation, dosage and package size must be listed as the descriptor.

PROPOSED RULES

2. An invoice indicating the cost of the "proprietary preparation" must be submitted to the carrier with the HCFA 1500 Form.
3. Reimbursement is limited to the lesser of the provider's charge or 20 percent above the actual cost of the item.

Authority: T.C.A. §§ 50-6-204, 50-6-205 (Supp. 2004), 50-6-233 (Repl. 1999).

0800-2-18-.13 AMBULANCE SERVICES GUIDELINES

- (1) All non-emergency ground and air ambulance service provided to workers' compensation claimants shall be pre-certified. Emergency ground and air ambulance services shall be retro-certified within 24 hours of the service or on the next business day.
- (2) All ground and air ambulance services shall be medically necessary and appropriate. Documentation, trip sheets, shall be submitted with the bill that states the condition that indicates the necessity of the ground and air ambulance service provided. It should readily indicate the need for transport via this mode rather than another less expensive form of transportation. The service billed shall be supported by the documentation submitted for review.
- (3) Billing shall be submitted to the employer or carrier on a properly completed HCFA 1500 claim form by HCPCS code. Hospital based or owned providers must submit charges on a HCFA 1500 form by HCPCS code.
- (4) Reimbursement shall be:

Based upon the lesser of the submitted charge or the prevailing reimbursement rate for ambulances within the geographic locality. These charges shall not exceed the prevailing charges in that locality for comparable services under comparable circumstances and commensurate with the services actually performed. Ambulance services shall be paid on a two (2) part basis, the first level being the level of care, the second being a mileage allowance. The services rendered are independent of the type of call received.

Authority: T.C.A. §§ 50-6-204, 50-6-205 (Supp. 2004), 50-6-233 (Repl. 1999).

0800-2-18-.14 CLINICAL PSYCHOLOGICAL SERVICE GUIDELINES

- (1) Reimbursement for psychological treatment services by any clinician other than a licensed psychiatrist shall be based on reasonableness and necessity and shall be reimbursed at 100% of the participating fees prescribed in the Medicare RBRVS System fee schedule (Medicare Fee Schedule). Treatment by a licensed psychiatrist shall be reimbursed as any other evaluation and management medical treatment under this Medical Fee Schedule.
- (2) Whenever such psychological treatment services exceed fifteen (15) sessions/visits, then such treatment shall be reviewed pursuant to the carrier's utilization review program in accordance with the procedures set forth in 0800-2-6 of the Division's Utilization Review rules before further psychological treatment services may be certified for payment by the carrier. Failure to properly certify such services as prescribed herein shall result in the forfeiture of any payment for un-

PROPOSED RULES

certified services. The initial utilization review of psychological treatment services after the first fifteen (15) sessions/visits shall, if necessary and appropriate, certify an appropriate number of sessions/visits. If necessary, further subsequent utilization review shall be conducted to certify additional psychological treatment services as is appropriate.

Authority: T.C.A. §§ 50-6-118, 50-6-125, 50-6-128, 50-6-204, 50-6-205 (Supp. 2004), 50-6-233 (Repl. 1999).

0800-2-18-.15 PENALTIES FOR VIOLATIONS OF FEE SCHEDULES

- (1) Providers shall not accept and employers or carriers shall not pay any amount for health care services provided for the treatment of a covered injury or illness or for any other services encompassed within the Medical Cost Containment Program Rules, Medical Fee Schedule Rules or the In-patient Hospital Fee Schedule Rules, when that amount exceeds the maximum allowable payment established by these Rules. Any provider accepting and any employer or carrier paying an amount in excess of the TDWC Medical Cost Containment Program Rules, Medical Fee Schedule Rules or the In-patient Hospital Fee Schedule Rules shall be in violation of these Rules and may, at the Commissioner's discretion, be subject to civil penalties of ten thousand dollars (\$10,000.00) per violation for each violation, which may be assessed severally against the provider accepting such fee and the carrier or employer paying the excessive fee whenever a pattern or practice of such activity is found. At the discretion of the Commissioner, the Commissioner's Designee, or an agency member appointed by the Commissioner, such provider may also be reported to the appropriate certifying board, and may be subject to exclusion from participating in providing care under the Act. Any other violation of the Medical Cost Containment Program Rules, Medical Fee Schedule Rules, or the In-patient Hospital Fee Schedule Rules shall subject the violator(s) to a civil penalty of not less than one hundred dollars (\$100.00) nor more than ten thousand dollars (\$10,000.00) per violation, at the discretion of the Commissioner, Commissioner's Designee, or an agency member appointed by the Commissioner.
- (2) A provider, employer or carrier found to be in violation of these Rules, whether a civil penalty is assessed or not, may request a contested case hearing by requesting such hearing in writing within fifteen (15) calendar days of issuance of a Notice of Violation and, if applicable, notice of assessment of civil penalties.
- (3) The request for a hearing shall be made to the Division in writing by an employer, carrier or provider which has been notified of its violation of these Rules, and if applicable, assessed a civil penalty.
- (4) Any request for a hearing shall be filed with the Division within fifteen (15) calendar days of the date of issuance of the Notice of Violation and, if applicable, of civil penalty by the Commissioner. Failure to file a request for a hearing within fifteen (15) calendar days of the date of issuance of a Notice of Violation shall result in the decision of the Commissioner, Commissioner's Designee, or an agency member appointed by the Commissioner being deemed a final order and not subject to further review.
- (5) The Commissioner, Commissioner's Designee, or an agency member appointed by the Commissioner shall have the authority to hear any matter as a contested case and determine if any civil penalty assessed should have been assessed.

PROPOSED RULES

- (6) Upon receipt of a timely filed request for a hearing, the Division shall issue a Notice of Hearing to all interested parties.

Authority: T.C.A. §§ 50-6-204, 50-6-205 (Supp. 2004), 50-6-233 (Repl. 1999).

The proposed rules set out herein were properly filed in the Department of State on the 9th day of May, 2005, and pursuant to the instructions set out above, and in the absence of the filing of an appropriate petition calling for a rulemaking hearing, will become effective on the 28th day of September, 2005. (05-08)

PROPOSED RULES

THE TENNESSEE DEPARTMENT OF LABOR AND WORKFORCE DEVELOPMENT - 0800 DIVISION OF WORKERS' COMPENSATION

CHAPTER 0800-2-19 IN-PATIENT HOSPITAL FEE SCHEDULE

Presented herein are proposed rules of the Tennessee Department of Labor and Workforce Development submitted pursuant to T.C.A. Section 4-5-202 in lieu of a rulemaking hearing. It is the intent of the Tennessee Department of Labor and Workforce Development to promulgate these rules without a rulemaking hearing unless a petition requesting such hearing is filed within thirty (30) days of the publication date of the issue of the Tennessee Administrative Register in which the proposed rules are published. Such petition to be effective must be filed with the Workers' Compensation Division, Second Floor of the Andrew Johnson Tower located at 710 James Robertson Parkway, Nashville, TN 37243-0661 and in the Department of State, Eighth Floor, Tennessee Tower, William Snodgrass Building, 312 8th Avenue North, Nashville, TN 37243, and must be signed by twenty-five (25) persons who will be affected by the rule, or submitted by a municipality which will be affected by the rules, or an association of twenty-five (25) or more members, or any standing committee of the General Assembly.

For a copy of these proposed rules, contact: Vickie Gregory, Administrative Secretary, Tennessee Department of Labor and Workforce Development, Division of Workers' Compensation, Andrew Johnson Tower, Second Floor, 710 James Robertson Parkway, Nashville, TN 37243-0661, (615) 253-1613.

NEW RULES

TABLE OF CONTENTS

0800-2-19-.01	General Rules	0800-2-19-.04	Preauthorization
0800-2-19-.02	Definitions	0800-2-19-.05	Other Services
0800-2-19-.03	Special Ground Rules – Inpatient Hospital Services	0800-2-19-.06	Penalties for Violations of Fee Schedules

0800-2-19-.01 GENERAL RULES

- (1) This In-patient Hospital Fee Schedule shall be effective July 1, 2005 and is applicable for all inpatient services as defined herein, and includes medical, surgical, rehabilitation, and/or psychiatric services rendered in a hospital to injured workers under the Tennessee Workers' Compensation Act. Maximum fees for outpatient hospital services are not addressed in this In-patient Hospital Fee Schedule, but are contained in the Medical Fee Schedule Rules, 0800-2-18-.01 et seq. This In-patient Hospital Fee Schedule is established pursuant to Tenn. Code Ann. § 50-6-204 (Supp. 2004) is effective July 1, 2005, and must be used in conjunction with the Medical Cost Containment Program Rules, 0800-2-17-.01 et seq. and the Medical Fee Schedule Rules, 0800-2-18-.01 et seq. as the definitions and general provisions set forth in those rules are incorporated as if set forth fully herein.
- (2) General Information
 - (a) Reimbursements shall be determined for services rendered in accordance with this Fee Schedule and shall be considered to be inclusive unless otherwise noted.

PROPOSED RULES

- (b) The most current Medicare procedures and guidelines are hereby adopted and incorporated as part of these Rules as if fully set out herein and shall be effective upon adoption and implementation by the CMS. Whenever there is no specific fee or methodology for reimbursement set forth in these Rules for a service, diagnostic procedure, equipment, etc., then the amount of reimbursement shall be at 100% of the 2005 CMS' Medicare amount and the most current effective Medicare guidelines and procedures shall be followed in arriving at the correct amount. The Medicare amount may, upon review by and at the Commissioner's discretion, be adjusted upward annually based upon CMS' annual Medicare Economic Index adjustment, but this amount shall never fall below the effective 2005 Medicare amount. Whenever there is no applicable Medicare code, the service, equipment, diagnostic procedure, etc. shall be reimbursed at the lesser of the usual and customary or the prevailing charge amount and be billed By Report.
- (c) Reimbursement for a compensable workers' compensation claim shall be the lesser of the hospital's usual and customary charges or the maximum amount allowed under this Inpatient Hospital Fee Schedule.
- (d) Inpatient hospitals shall be grouped into the following separate peer groupings:

Peer Group	1	Hospitals
Peer Group	2	Rehabilitation Hospitals
Peer Group	3	Psychiatric Hospitals
- (e) For each inpatient claim submitted, the provider shall assign a Medicare Diagnosis Related Group ("DRG") code which appropriately reflects the patient's primary cause of hospitalization.
- (f) The In-patient Hospital Fee Schedule shall become effective July 1, 2005, is applicable to all services rendered that date and thereafter, regardless of date of injury, and shall be reviewed annually and may be updated annually.
- (g) Ongoing analysis will be conducted as to the projected savings of this schedule, as well as any impact on patient services.
- (h) Preauthorization is required for specific inpatient services.

Authority: T.C.A. §§ 50-6-125, 50-6-128, 50-6-204, 50-6-205 (Supp. 2004).

0800-2-19-.02 DEFINITIONS

- (1) "Administrator" means the chief administrative officer of the Division of Workers' Compensation of the Tennessee Department of Labor and Workforce Development.
- (2) "Allowed Charges" or "Allowable Charges" shall mean charges reviewed and approved under an appropriate audit and utilization review by the carrier as prescribed in the Division's Rules, or as determined by the Commissioner or the Commissioner's designee after consultation with the Division's Medical Director.
- (3) "Commissioner" means the Commissioner of the Tennessee Department of Labor and Workforce Development.

PROPOSED RULES

- (4) "Division" means the Division of Workers' Compensation of the Tennessee Department of Labor and Workforce Development.
- (5) DRG – Medicare classifications of diagnosis in which patients demonstrate similar resource consumption and length of stay patterns.
- (6) In-patient Services - Services rendered to a person who is formally admitted to a hospital and whose length of stay exceeds 23 hours.
- (7) Institutional Services - All non-physician services rendered within the institution by an agent of the institution.
- (8) Length of Stay ("LOS") - Number of days of admission where patient appears on midnight census. Last day of stay shall count as an admission day if it is medically necessary for the patient to remain in the hospital beyond 12:00 noon.
- (9) Medical Admission - Any hospital admission where the primary services rendered are not surgical, psychiatric, or rehabilitative in nature.
- (10) Stop-Loss Payment ("SLP") - An independent method of payment for an unusually costly or lengthy stay.
- (11) Stop-Loss Reimbursement Factor ("SLRF") - A factor established by the Division to be used as a multiplier to establish a reimbursement amount when total hospital charges have exceeded specific stop-loss thresholds.
- (12) Stop-Loss Threshold ("SLT") - Threshold of total charges established by the Division, beyond which reimbursement is calculated by multiplying the applicable Stop-Loss Reimbursement Factor times the total charges identifying that particular threshold.
- (13) Surgical Admission - Any hospital admission where there is an operating room charge, the patient has a surgical procedure code, or the patient has a surgical DRG as defined by the CMS.
- (14) Transfers Between Facilities - To move or remove a patient from one facility to another for a purpose related to obtaining or continuing medical care. May or may not involve a change in the admittance status of the patient, i.e. patient transported from one facility to another to obtain specific care, diagnostic testing, or other medical services not available in facility in which patient has been admitted. Includes costs related to transportation of patient to obtain medical care.
- (15) "Trauma Admission" - means any hospital admission in which the patient has a diagnosis code of 800 to 959.99.
- (16) "Usual and customary charge" means a particular provider's average charge for a procedure to all payment sources, and includes itemized charges previously billed separately which are included in the package for that procedure as defined by this rule
- (17) Workers' Compensation Standard Per Diem Amount ("SPDA") - A standardized per diem amount established for the reimbursement of hospitals for services rendered.

Authority: T.C.A. §§ 50-6-125, 50-6-128, 50-6-204, 50-6-205 (Supp. 2004).

PROPOSED RULES

0800-2-19-.03 SPECIAL GROUND RULES – INPATIENT HOSPITAL SERVICES.

- (1) This section defines the reimbursement procedures and calculations for inpatient health care services by all hospitals. Hospital reimbursement is divided into two (2) groups based on type of admission (surgical or non-surgical (medical)) and length of stay (less than eight (8) days/over seven (7) days). Rehabilitation and Psychiatric hospitals are grouped separately.
- (2) General Information
 - (a) For each inpatient claim submitted, the provider shall assign a Diagnosis Related Group (DRG) code which appropriately reflects the patient's primary cause for hospitalization to determine average length of stay and for tracking purposes. Hospitals within each peer group are subject to a maximum amount per inpatient day.
 - (b) The maximum per diem rates to be used in calculating the reimbursement rate is as follows:
 1. Peer Group 1 \$1,800.00 Surgical adm for the first seven (7) days;
1,500.00 per day thereafter (surgical adm.)
Includes Intensive Care (ICU) & Critical Care (CCU)

1,500.00 Medical adm. for first seven (7) days;
1,250.000 per day thereafter (medical adm.)
 2. Peer Group 2 1,000.00 For the first seven (7) days;
(Rehabilitation) 800.00 per day thereafter
 3. Peer Group 3 700.00 Psychiatric Hospitals (applicable to
chemical dependency as well.)
 - (c) All trauma care at any licensed Level 1 Trauma Center shall be reimbursed at a maximum rate of \$3,000.00 per day for each day of patient stay.
 - (d) Surgical implants shall be reimbursed separately and in addition to the per diem hospital charges.
 1. Reimbursement for trauma inpatient hospital services shall be limited to the lesser of the maximum allowable as calculated by the appropriate per diem rate, or the hospital's billed charges minus any non-covered charges.
 2. Non-covered charges are: convenience items, charges for services not related to the work injury/illness services that were not certified by the payer or their representative as medically necessary.
 3. Additional reimbursement may be made in addition to the per diem for implantables (i.e. rods, pins, plates and joint replacements, etc.). The reimbursement for the implantables is limited to hospital's cost plus fifteen percent (15%) of invoice, up to a maximum of invoice plus \$1,000.00. Implantables shall be billed using the appropriate HCPCS codes, when available. Billing for implantables must be accompanied by an invoice when requested by the payer.

PROPOSED RULES

4. The following items are not included in the per diem reimbursement to the facility and may be reimbursed separately. All of these items must be listed with the HCPCS code.
 - (i) Durable Medical Equipment
 - (ii) Orthotics and Prosthetics
 - (iii) Implantables
 - (iv) Ambulance Services
 - (v) Take home medications and supplies
 - (e) The above listed items will be reimbursed according to the Medical Cost Containment Program Rules and Medical Fee Schedule Rules payment limits. Items not listed in the fee schedule Rules will be reimbursed at the usual and customary rate, unless otherwise indicated herein.
 - (f) Per diem rates are all inclusive (with the exception of those items listed in 4 above). The services must be medically necessary and delivered at the appropriate level/site of service.
 - (g) The In-patient Hospital Fee Schedule allows for independent reimbursement on a case-by-case basis if the particular care exceeds the Stop-Loss Threshold.
- (3) Reimbursement Calculations
- (a) Explanation
 1. Each admission is assigned an appropriate DRG.
 2. The applicable Standard Per Diem Amount (“SPDA”) is multiplied by the length of stay (“LOS”) for that admission.
 3. The Workers’ Compensation Reimbursement Amount (“WCRA”) is the total amount of reimbursement to be made for that particular admission.
 - (b) Formula: $LOS \times SPDA = WCRA$
 - (c) Example: DRG 222: Knee Procedures W/O CC

Hospital Peer Group: 1-Surgical admission:
Maximum rate per day: \$1,800 first seven (7) days/\$1,500 per day each day thereafter
Number billed days: 9
Billed charges: \$15,600

Maximum Allowable Payment: \$15,600
- (4) Stop-Loss Method

PROPOSED RULES

- (a) Stop-loss is an independent reimbursement factor established to ensure fair and reasonable compensation to the hospital for unusually costly services rendered during treatment to an injured worker.
- (b) Explanation
1. To be eligible for stop loss payment, the total Allowed Charges for a hospital admission must exceed the hospital maximum payment, as determined by the hospital maximum payment rate per day, by at least \$15,000.
 2. This stop-loss threshold is established to ensure compensation for unusually extensive services required during an admission.
 3. Once the allowed charges reach the stop-loss threshold, reimbursement for all additional charges shall be made based on a stop-loss payment factor of 80%.
 4. The additional charges are multiplied by the Stop-Loss Reimbursement Factor (SLRF) and added to the maximum allowable payment.
- (c) Formula: (Additional Charges x SLRF) + Maximum Allowable Payment = WCRA
- (d) Example: DRG 222: Knee Procedures W/O CC

Hospital Peer Group: 1 –Surgical admission
Maximum rate per day: \$1,800 for first 7 days; 1,500 for 2 additional days
Number Billed Days: 9
Total Billed Charges: \$37,600.00
Maximum allowable payment for
Normal DRG stay \$15,600
Versus: billed charges \$37,600
Amount Payable Before Stop-Loss,
Lower of Charge vs. Maximum Allowable..... \$15,600
Total difference, charges over and above maximum payments \$22,000
Difference over and above \$15,000 Stop-loss is \$7,000.00
Payable under Stop-loss (80% of 7,000.00).....\$5,600.00
Total payment
due hospital: \$21,200.00 (15,600+5,600)

(5) Billing for Inpatient Admissions

- (a) All bills for inpatient institutional services should be submitted on the standard UB-82 (HCFA 1450) form or any revision to that form approved for use by the CMS.

Authority: T.C.A. §§ 50-6-125, 50-6-128, 50-6-204, 50-6-205 (Supp. 2004).

0800-2-19-.04. PREAUTHORIZATION.

(1) Procedures For Requesting Preauthorization

PROPOSED RULES

- (a) The insurance carrier shall be liable for the reasonable and necessary medical costs relating to the health care treatments and services listed in subparagraph (g) of this Rule required to treat a compensable injury, when any of the following situations occur:
 - 1. the treating doctor, his/her designated representative, or injured employee has received preauthorization from the carrier prior to the health care treatments or services;
 - 2. the carrier has failed to communicate approval or denial of preauthorization within seven (7) business days of a provider's request for preauthorization; or
 - 3. when ordered by the Division.
- (b) The insurance carrier shall designate an accessible direct telephone number, and may also designate a facsimile number for use by the provider or the provider's designated representative or the injured employee to request preauthorization during normal business hours. The direct number shall be answered or the facsimile responded to, by the carrier's agent who is delegated to approve or deny requests for preauthorization, within the time limits established in subsection (d) of this section.
- (c) Prior to the date of proposed treatment or services, the provider or the provider's designated representative, shall notify the insurance carrier's delegated agent, by telephone or transmission of a facsimile, of the recommended treatment or service listed in subparagraph (g) of this Rule. Notification shall include the medical information to substantiate the need for the treatment or service recommended. If requested to do so by the carrier, the treating doctor shall also notify the insurance carrier of the location and estimated date of the recommended treatment or service, and the name of the health care provider performing the treatment or service, if other than the provider. Designated representative includes, but is not limited to, office staff, hospitals, etc.
- (d) Within seven (7) business days of the provider's request for preauthorization, the insurance carrier's delegated agent shall notify the provider or the provider's designated representative, by telephone or transmission of a facsimile, of the insurance carrier's decision to grant or deny preauthorization. Failure of the carrier to communicate its approval or denial of authorization within seven (7) business days of a provider's request for preauthorization shall automatically be deemed an approval of the preauthorization request. When the insurance carrier approves preauthorization, the insurance carrier shall send written approval, or if denying preauthorization, shall send documentation identifying the reasons for denial. Notification shall be sent to the injured employee, the injured employee's representative if known, and the provider or the provider's designated representative, within 24 hours after notification of denial or approval.
- (e) The insurance carrier shall maintain accurate records to reflect information regarding the preauthorization request and approval/denial process.
- (f) If a dispute arises over denial of preauthorization by the insurance carrier, the doctor or the injured employee may file a Request for Assistance with a Benefit Review Specialist.
- (g) The health care treatments and services requiring preauthorization are: all nonemergency hospitalizations and non-emergency transfers between facilities.

PROPOSED RULES

Authority: T.C.A. §§ 50-6-125, 50-6-128, 50-6-204, 50-6-205 (Supp. 2004).

0800-2-19-.05 OTHER SERVICES

- (1) Pharmacy Services
 - (a) Pharmaceutical services rendered as part of inpatient care are considered inclusive within the inpatient fee schedule and shall not be reimbursed separately.
 - (b) All retail pharmaceutical services rendered shall be reimbursed in accordance with the Pharmacy Schedule Guidelines.
- (2) Professional Services
 - (a) All non-institutional professional services will be reimbursed in accordance with the Division's Medical Cost Containment Program Rules and Medical Fee Schedule Rules which must be used in conjunction with these Rules.

Authority: T.C.A. §§ 50-6-118, 50-6-125, 50-6-128, 50-6-204, 50-6-205 (Supp. 2004).

0800-2-19-.06 PENALTIES FOR VIOLATIONS OF FEE SCHEDULES

- (1) Providers shall not accept and employers or carriers shall not pay any amount for health care services provided for the treatment of a covered injury or illness or for any other services encompassed within the Medical Cost Containment Program Rules, Medical Fee Schedule Rules or the In-patient Hospital Fee Schedule Rules, when that amount exceeds the maximum allowable payment established by these Rules. Any provider accepting and any employer or carrier paying an amount in excess of the Division's Medical Cost Containment Program Rules, Medical Fee Schedule Rules or the In-patient Hospital Fee Schedule Rules shall be in violation of these Rules and may, at the Commissioner's discretion, be subject to civil penalties of ten thousand dollars (\$10,000.00) per violation for each violation, which may be assessed severally against the provider accepting such fee and the carrier or employer paying the excessive fee, whenever a pattern or practice of such activity is found. At the discretion of the Commissioner, the Commissioner's Designee, or an agency member appointed by the Commissioner, such provider may also be reported to the appropriate certifying board, and may be subject to exclusion from participating in providing care under the Act. Any other violation of the Medical Cost Containment Program Rules, Medical Fee Schedule Rules, or the In-patient Hospital Fee Schedule Rules shall subject the alleged violator(s) to a civil penalty of not less than one hundred dollars (\$100.00) nor more than ten thousand dollars (\$10,000.00) per violation, at the discretion of the Commissioner, Commissioner's Designee, or an agency member appointed by the Commissioner.
- (2) A provider, employer or carrier found to be in violation of these Rules, whether a civil penalty is assessed or not, may request a contested case hearing by requesting such hearing in writing within fifteen (15) days of issuance of a Notice of Violation and, if applicable, the notice of assessment of civil penalties.

PROPOSED RULES

- (3) The request for a hearing shall be made to the Division in writing by an employer, carrier or provider which has been notified of its violation of these Rules, and if applicable, assessed a civil penalty.
- (4) Any request for a hearing shall be filed with the Division within fifteen (15) calendar days of the date of issuance of the Notice of Violation and, if applicable, of civil penalty by the Commissioner. Failure to file a request for a hearing within fifteen (15) calendar days of the date of issuance of a Notice of Violation shall result in the decision of the Commissioner, Commissioner's Designee, or an agency member appointed by the Commissioner becoming a final order and not subject to further review.
- (5) The Commissioner, Commissioner's Designee, or an agency member appointed by the Commissioner shall have the authority to hear the matter as a contested case and determine if any civil penalty assessed should have been assessed.
- (6) Upon receipt of a timely filed request for a hearing, the Division shall issue a Notice of Hearing to all interested parties.

Authority: *T.C.A. §§ 50-6-204, 50-6-205 (Supp. 2004), 50-6-233 (Repl. 1999).*

The proposed rules set out herein were properly filed in the Department of State on the 9th day of May, 2005, and pursuant to the instructions set out above, and in the absence of the filing of an appropriate petition calling for a rulemaking hearing, will become effective on the 28th day of September, 2005. (05-09)

PUBLIC NECESSITY RULES

PUBLIC NECESSITY RULES NOW IN EFFECT

FOR TEXT OF PUBLIC NECESSITY RULE, SEE T.A.R. CITED

- 0180 - Department of Financial Institutions - Compliance Division - Public Necessity rules relating to registration of loan originators, chapter 0180-17 Rules Pertaining to Mortgage Lending, Loan Servicing and Loan Brokering, 4 T.A.R. (April 2005) - Filed March 8, 2005; effective through August 20, 2005. (03-09)
- 0620 - Department of Finance and Administration - Division of Mental Retardation Services - Public necessity rules relating to determining the funding mechanism/amounts to be paid to the Division's contractors who aid the mentally retarded in Tennessee, chapter 0940-4-3 Methodology Utilized to Determine Payments to Service providers (Rate Structure), 2 T.A.R. (February 2005) - Filed January 25, 2005; effective through July 9, 2005. (01-20)
- 0620 - Department of Finance and Administration - Bureau of TennCare - Public Necessity Rules required to conform the current TennCare Standard rules to reflect changes resulting from the amendment of the TennCare waiver, chapter 1200-13-14 TennCare Medicaid, 5 T.A.R. (May 2005) - Filed April 29, 2005; effective through October 11, 2005. (04-18)
- 0620 - Department of Finance and Administration - Bureau of TennCare - Public Necessity Rules required to conform the current TennCare Standard rules to reflect changes resulting from the amendment of the TennCare waiver, chapter 1200-13-14 TennCare Standard, 5 T.A.R. (May 2005) - Filed April 29, 2005; effective through October 11, 2005. (04-17)
- 1640 - TN Student Assistance Corporation - Public necessity rules relative to the Tennessee Lottery Scholarship Program, chapter 1640-1-19 Tennessee Education Lottery Scholarship Program, 2 T.A.R. (February 2005) - Filed January 25, 2005; effective July 9, 2005. (01-20)

PUBLIC NECESSITY RULES

**TENNESSEE DEPARTMENT OF FINANCE AND ADMINISTRATION - 0620
BUREAU OF TENNCARE**

**CHAPTER 1200-13-13
TENNCARE MEDICAID**

STATEMENT OF NECESSITY REQUIRING PUBLIC NECESSITY RULES

I am herewith submitting amendments to the rules of the Tennessee Department of Finance and Administration, Bureau of TennCare, for promulgation pursuant to the public necessity provisions of the Uniform Administrative Procedures Act, T.C.A. § 4-5-209 and the Medical Assistance Act, T.C.A. § 71-5-134.

The State of Tennessee must comply with the federally passed Balanced Budget Act of 2003. The Balanced Budget Act of 2003 sets forth regulations for Managed Care Organizations regarding the provision of care for Medicaid enrollees. The Centers for Medicare and Medicaid Services (CMS) require that TennCare rules reflect appeals language in 42 CFR § 438. In order to obtain approval of recent contract amendments, TennCare must demonstrate full compliance with the Balanced Budget Act, specifically the appeal requirements.

Tennessee Code Annotated, Section 71-5-134, states that in order to comply with or to implement the provisions of any federal waiver or state plan amendment obtained pursuant to the Medical Assistance Act as amended by Acts 1993, the Commissioner of Finance and Administration is authorized to promulgate public necessity rules pursuant to Tennessee Code Annotated, Section 4-5-209.

I have made a finding that these amendments are required to modify the current TennCare rules to reflect changes resulting from the Balanced Budget Act of 2003. Changes to the rules include requiring that Managed Care Corporations comply with specific BBA appeal requirements.

For a copy of this public necessity rule, contact George Woods at the Bureau of TennCare by mail at 729 Church Street, Nashville, Tennessee 37247-6501 or by telephone at (615) 741-0145.

J. D. Hickey
Deputy Commissioner
Tennessee Department of Finance
and Administration

PUBLIC NECESSITY RULES

PUBLIC NECESSITY RULES

OF

TENNESSEE DEPARTMENT OF FINANCE AND ADMINISTRATION

BUREAU OF TENNCARE

CHAPTER 1200-13-13

TENNCARE MEDICAID

AMENDMENTS

Subparagraph (b) of paragraph (27) of rule 1200-13-13-.01 Definitions (TennCare Medicaid) is deleted in its entirety and replaced with a new subparagraph (b) which shall read as follows:

- (b) An MCC's failure to provide timely prior authorization of a TennCare service. In no event shall a prior authorization decision be deemed timely unless it is granted within fourteen (14) calendar days of the MCC's receipt of a request for such authorization. A shorter period is required if a more prompt response is medically necessary in light of the enrollee's condition and the urgency of his need, as defined by a prudent lay person.

Subparagraph (d) of paragraph (105) of rule 1200-13-13-.01 Definitions (TennCare Medicaid) is amended by replacing "December 31, 2002" in the first sentence with "December 31, 2001" so as amended subparagraph (d) shall read as follows:

- (d) Had Medicare as of December 31, 2001 (but not Medicaid) and were enrolled in the TennCare Program as of December 31, 2001, and who continue to meet the definition of "uninsurable" in effect at that time. Effective January 1, 2003 these individuals are eligible only for the TennCare Standard pharmacy benefit package; or

Part 2. of subparagraph (b) of paragraph (1) of rule 1200-13-13-.11 Appeal of Adverse Actions Affecting TennCare Services or Benefits (TennCare Medicaid) is amended by deleting the word and number "twenty-one (21)" and replacing them with the word and number "fourteen (14)" so as amended part 2. shall read as follows:

- 2. Written notice of an MCC's decision in response to a request by or on behalf of an enrollee for medical or related services must be provided within fourteen (14) calendar days of receipt of the request; however, a shorter period is required if a more prompt response is medically necessary in light of the enrollee's condition and the urgency of his/her need, as defined by a prudent lay person.

Subparagraph (e) of paragraph (2) of rule 1200-13-13-.11 Appeal of Adverse Actions Affecting TennCare Services or Benefits (TennCare Medicaid) is amended by adding the sentence "Oral appeals shall be followed up with an oral filing with a written, signed appeal, however, if the enrollee does not follow up in writing, the appeal will continue for resolution or for hearing" so as amended subparagraph (e) shall read as follows:

- (e) To appeal in person, by telephone, or in writing. Reasonable accommodations shall be made for persons with disabilities who require assistance with his/her appeal, such as an appeal by TDD services or other communication device for people with disabilities. Written requests for appeals made at county TDHS offices shall be stamped, and immediately forwarded to

PUBLIC NECESSITY RULES

the TennCare Bureau for processing and entry in the central registry. Oral appeals shall be followed up with an oral filing with a written, signed appeal; however, if the enrollee does not follow up in writing, the appeal will continue for resolution or for hearing;

Subparagraph (a) of paragraph (7) of rule 1200-13-13-.11 Appeal of Adverse Actions Affecting TennCare Services or Benefits (TennCare Medicaid) is deleted in its entirety and replaced with a new subparagraph (a) which shall read as follows:

- (a) Subject to the provisions of subparagraphs (7)(e) and (f) below and to provisions relating to medical contraindication (paragraph (8)), the failure of an MCC to act upon a request for prior approval within fourteen (14) days as provided in (1)(b)2. above shall result in automatic authorization of the requested service.

Authority: T.C.A. §§4-5-209, 71-5-105, 71-5-109, Executive Order No. 23.

The Public Necessity rules set out herein were properly filed in the Department of State on the 5th day of May, 2005, and will be effective from the date of filing for a period of 165 days. The Public Necessity rules remain in effect through the 17th day of October, 2005. (05-05)

PUBLIC NECESSITY RULES

**TENNESSEE DEPARTMENT OF FINANCE AND ADMINISTRATION - 0620
BUREAU OF TENNCARE**

**CHAPTER 1200-13-14
TENNCARE STANDARD**

STATEMENT OF NECESSITY REQUIRING PUBLIC NECESSITY RULES

I am herewith submitting amendments to the rules of the Tennessee Department of Finance and Administration, Bureau of TennCare, for promulgation pursuant to the public necessity provisions of the Uniform Administrative Procedures Act, T.C.A. § 4-5-209 and the Medical Assistance Act, T.C.A. § 71-5-134.

The State of Tennessee must comply with the federally passed Balanced Budget Act of 2003. The Balanced Budget Act of 2003 sets forth regulations for Managed Care Organizations regarding the provision of care for Medicaid enrollees. The Centers for Medicare and Medicaid Services (CMS) require that TennCare rules reflect appeals language in 42 CFR § 438. In order to obtain approval of recent contract amendments, TennCare must demonstrate full compliance with the Balanced Budget Act, specifically the appeal requirements.

Tennessee Code Annotated, Section 71-5-134, states that in order to comply with or to implement the provisions of any federal waiver or state plan amendment obtained pursuant to the Medical Assistance Act as amended by Acts 1993, the Commissioner of Finance and Administration is authorized to promulgate public necessity rules pursuant to Tennessee Code Annotated, Section 4-5-209.

I have made a finding that these amendments are required to modify the current TennCare rules to reflect changes resulting from the Balanced Budget Act of 2003. Changes to the rules include requiring that Managed Care Corporations comply with specific BBA appeal requirements.

For a copy of this public necessity rule, contact George Woods at the Bureau of TennCare by mail at 729 Church Street, Nashville, Tennessee 37247-6501 or by telephone at (615) 741-0145.

J. D. Hickey
Deputy Commissioner
Tennessee Department of Finance
and Administration

PUBLIC NECESSITY RULES

**PUBLIC NECESSITY RULES
OF
TENNESSEE DEPARTMENT OF FINANCE AND ADMINISTRATION**

BUREAU OF TENNCARE

**CHAPTER 1200-13-14
TENNCARE STANDARD**

AMENDMENTS

Subparagraph (b) of paragraph (27) of rule 1200-13-14-.01 Definitions (TennCare Standard) is deleted in its entirety and replaced with a new subparagraph (b) which shall read as follows:

- (b) An MCC's failure to provide timely prior authorization of a TennCare service. In no event shall a prior authorization decision be deemed timely unless it is granted within fourteen (14) calendar days of the MCC's receipt of a request for such authorization. A shorter period is required if a more prompt response is medically necessary in light of the enrollee's condition and the urgency of his need, as defined by a prudent lay person.

Subparagraph (d) of paragraph (105) of rule 1200-13-14-.01 Definitions (TennCare Standard) is amended by replacing "December 31, 2002" in the first sentence with "December 31, 2001" so as amended subparagraph (d) shall read as follows:

- (d) Had Medicare as of December 31, 2001 (but not Medicaid) and were enrolled in the TennCare Program as of December 31, 2001, and who continue to meet the definition of "uninsurable" in effect at that time. Effective January 1, 2003 these individuals are eligible only for the TennCare Standard pharmacy benefit package; or

Part 2. of subparagraph (b) of paragraph (1) of rule 1200-13-14-.11 Appeal of Adverse Actions Affecting TennCare Services or Benefits (TennCare Standard) is amended by deleting the word and number "twenty-one (21)" and replacing them with the word and number "fourteen (14)" so as amended part 2. shall read as follows:

- 2. Written notice of an MCC's decision in response to a request by or on behalf of an enrollee for medical or related services must be provided within fourteen (14) calendar days of receipt of the request; however, a shorter period is required if a more prompt response is medically necessary in light of the enrollee's condition and the urgency of his/her need, as defined by a prudent lay person.

Subparagraph (e) of paragraph (2) of rule 1200-13-14-.11 Appeal of Adverse Actions Affecting TennCare Services or Benefits (TennCare Standard) is amended by adding the sentence "Oral appeals shall be followed up with an oral filing with a written, signed appeal, however, if the enrollee does not follow up in writing, the appeal will continue for resolution or for hearing" so as amended subparagraph (e) shall read as follows:

- (e) To appeal in person, by telephone, or in writing. Reasonable accommodations shall be made for persons with disabilities who require assistance with his/her appeal, such as an appeal by TDD services or other communication device for people with disabilities. Written requests for appeals made at county TDHS offices shall be stamped, and immediately forwarded to the TennCare Bureau for processing and entry in the central registry. Oral appeals shall be

PUBLIC NECESSITY RULES

followed up with an oral filing with a written, signed appeal; however, if the enrollee does not follow up in writing, the appeal will continue for resolution or for hearing;

Subparagraph (a) of paragraph (7) of rule 1200-13-14-.11 Appeal of Adverse Actions Affecting TennCare Services or Benefits (TennCare Standard) is deleted in its entirety and replaced with a new subparagraph (a) which shall read as follows:

- (a) Subject to the provisions of subparagraphs (7)(e) and (f) below and to provisions relating to medical contraindication (paragraph (8)), the failure of an MCC to act upon a request for prior approval within fourteen (14) days as provided in (1)(b)2. above shall result in automatic authorization of the requested service.

Authority: T.C.A. §§4-5-209, 71-5-105, 71-5-109, Executive Order No. 23.

The Public Necessity rules set out herein were properly filed in the Department of State on the 5th day of May, 2005, and will be effective from the date of filing for a period of 165 days. The Public Necessity rules remain in effect through the 17th day of October, 2005. (05-06)

PUBLIC NECESSITY RULES

#2b	Employee's/Obligor's Name (Last, First, MI)
Employer's/Withholder's Address	#3b
#2c	Employee's/Obligor's Social Security Number
Employee's/Obligor's Case Identifier	#3c
#2d	#3d
Withholder's Federal EIN Number (if known)	Obligee's Name (Last, First, MI) Employer's/

ORDER INFORMATION: This document is based on the support or withholding order from _____.

You are required by law to deduct these amounts from the employee's/obligor's income until further notice.

\$ _____ # 5a	Per _____ # 5b	current child support	#13
\$ _____ # 6a	Per _____ # 6b	past-due child support - Arrears greater than 12 weeks?	☐yes ☐no
\$ _____ # 7a	Per _____ # 7b	current cash medical support	
\$ _____ # 8a	Per _____ # 8b	past-due cash medical support	
\$ _____ # 9a	Per _____ # 9b	spousal support	
\$ _____ #10a	Per _____ #10b	past-due spousal support	
\$ _____ #11a	Per _____ #11b	other (specify) _____	#11c

for a total of \$ _____ #12a per _____ #12b to be forwarded to the payee below.

You do not have to vary your pay cycle to be in compliance with the support order. If your pay cycle does not match the ordered payment cycle, withhold one of the following amounts:

\$ _____ # 14a per weekly pay period.	\$ _____ # 14c per semimonthly pay period (twice a month).
\$ _____ # 14b per biweekly pay period (every two weeks).	\$ _____ # 14d per monthly pay period.

REMITTANCE INFORMATION: When remitting payment, provide the pay date/date of withholding and the case identifier. If the employee's/obligor's principal place of employment is _____ #15, begin withholding no later than the first pay period occurring _____ #16 days after the date of _____ #17. Send payment within _____ #18 working days of the pay date/date of withholding. The total withheld amount, including your fee, may not exceed _____ #19 % of the employee's/obligor's aggregate disposable weekly earnings.

If the employee's/obligor's principal place of employment is not _____ #20, for limitations on withholding, applicable time requirements, and any allowable employer fees, follow the laws and procedures of the employee's/obligor's principal place of employment (see #3 and #9, ADDITIONAL INFORMATION TO EMPLOYERS AND OTHER WITHHOLDERS).

Make check payable to: _____ #21(Payee and Case identifier) Send check to: _____ #22

If remitting payment by EFT/EDI, call _____ #23a before first submission. Use this FIPS code: _____ #23b :

Bank routing number: _____ #23c Bank account number: _____ #23d

If this is an Order/Notice to Withhold:	If this is a Notice of an Order to Withhold:
24a Print Name _____	25a Print Name _____
24b Title of Issuing Official _____ Mandatory	25b Title (if appropriate) _____

24c Signature and Date _____ (if required by state or tribal law) 25c Signature and Date _____

24d IV-D Agency Court 25d Attorney Individual Private Entity

NOTE: Non-IV-D Attorneys, individuals, and non-governmental entities must submit a Notice of an Order to Withhold and include a copy of the income withholding order unless, under a state's law, an attorney in that state may issue an income withholding order. In that case, the attorney may submit an Order/Notice to Withhold and include a copy of the state law authorizing the attorney to issue an income withholding order/notice.

IMPORTANT: The person completing this form is advised that the information on this form may be shared with the obligor.

OMB 0970-0154

PUBLIC NECESSITY RULES

ADDITIONAL INFORMATION TO EMPLOYERS AND OTHER WITHHOLDERS

#26 If checked, you are required to provide a copy of this form to your employee/obligor. If your employee works in a state that is different from the state that issued this order, a copy must be provided to your employee/obligor even if the box is not checked.

1. Priority: Withholding under this Order or Notice has priority over any other legal process under state law (or tribal law, if applicable) against the same income. If there are federal tax levies in effect, please notify the contact person listed below. (See 10 below.)

2. Combining Payments: You may combine withheld amounts from more than one employee's/obligor's income in a single payment to each agency/party requesting withholding. You must, however, separately identify the portion of the single payment that is attributable to each employee/obligor.

3. Reporting the Paydate/Date of Withholding: You must report the paydate/date of withholding when sending the payment. The paydate/date of withholding is the date on which the amount was withheld from the employee's wages. You must comply with the law of the state of employee's/obligor's principal place of employment with respect to the time periods within which you must implement the withholding and forward the support payments.

4. Employee/Obligor with Multiple Support Withholdings: If there is more than one Order or Notice against this employee/obligor and you are unable to honor all support Orders or Notices due to federal, state, or tribal withholding limits, you must follow the state or tribal law/procedure of the employee's/obligor's principal place of employment. You must honor all Orders or Notices to the greatest extent possible. (See 9 below.)

5. Termination Notification: You must promptly notify the Child Support Enforcement (IV-D) Agency and/or the contact person listed below when the employee/obligor no longer works for you. Please provide the information requested and return a complete copy of this Order or Notice to the Child Support Enforcement (IV-D) Agency and/or the contact person listed below. (See 10 below.)

THE EMPLOYEE/OBLIGOR NO LONGER WORKS FOR: _____

EMPLOYEE'S/OBLIGOR'S NAME: _____ CASE IDENTIFIER: _____

DATE OF SEPARATION FROM EMPLOYMENT: _____

LAST KNOWN HOME ADDRESS: _____

N E W

EMPLOYER/ADDRESS: _____

6. Lump Sum Payments: You may be required to report and withhold from lump sum payments such as bonuses, commissions, or severance pay. If you have any questions about lump sum payments, contact the Child Support Enforcement (IV-D) Agency.

7. Liability: If you have any doubts about the validity of the Order or Notice, contact the agency or person listed below under 10. If you fail to withhold income as the Order or Notice directs, you are liable for both the accumulated amount you should have withheld from the employee's/obligor's income and any other penalties set by state or tribal law/procedure.

#27 _____

8. Anti-discrimination: You are subject to a fine determined under state or tribal law for discharging an employee/obligor from employment, refusing to employ, or taking disciplinary action against any employee/obligor because of a child support withholding.

#28 _____

9. Withholding Limits: For state orders, you may not withhold more than the lesser of: 1) the amounts allowed by the Federal Consumer Credit Protection Act (15 U.S.C. § 1673(b)); or 2) the amounts allowed by the state of the employee's/obligor's

PUBLIC NECESSITY RULES

principal place of employment. The federal limit applies to the aggregate disposable weekly earnings (ADWE). ADWE is the net income left after making mandatory deductions such as: state, federal, local taxes, Social Security taxes, statutory pension contributions, and Medicare taxes. The Federal CCPA limit is 50% of the ADWE for child support and alimony, which is increased by 1) 10% if the employee does not support a second family; and/or 2) 5% if arrears greater than 12 weeks. For tribal orders, you may not withhold more than the amounts allowed under the law of the issuing tribe. For tribal employers who receive a state order, you may not withhold more than the amounts allowed under the law of the state that issued the order.

Child(ren)'s Names and Additional Information: #29

Tennessee Employers/Payers of Income should refer to the Department's Rule 1240-2-2-.05, available on the Internet at <http://www.state.tn.us/sos/rules/1240/1240-02/1240-02-02.pdf>, for state specific information about the priority and proration of payments if multiple Orders/Notices are received for one employee.

10. If you or your employee/obligor have any questions, contact #30a by telephone at #30b by Fax at #30c or by internet at #30d .

Instructions to complete the Order/Notice to Withhold Income for Child Support or Notice of an Order to Withhold Income for Child Support

The Order/Notice to Withhold Income for Child Support (Order/Notice) or Notice of an Order to Withhold Income for Child Support (Notice) is a standardized form used for income withholding in tribal, intrastate, interstate, and intergovernmental cases. Please note that information provided on this form may be shared with the obligor. When completing the form, please include the following information.

The following information 1a – 1g refers to the government agency, non-government entity, or individual completing and sending this form to the employer.

- 1a. Check whether this is an Order/Notice to Withhold Income for Child Support or a Notice of an Order to Withhold Income for Child Support. Attorneys, individuals, and non-governmental entities must submit a Notice of an Order to Withhold and include a copy of the income withholding order unless, under a state's law, an attorney in that state may issue an income withholding order/notice. In that case, the attorney may submit an Order/Notice to Withhold and include a copy of the state law authorizing the attorney to issue an income withholding order/notice.
- 1b. Check the appropriate status of the Order or Notice.
- 1c. Date this form is completed and/or signed.
- 1d. Name of the state, tribe or territory sending this form. This must be a governmental entity.
- 1e. Name of the county, city, district, or reservation sending this Order or Notice, if appropriate. This must be a governmental entity.
- 1f. Check and indicate the non-governmental entity or individual sending this Order or Notice. Complete this item only if a non-governmental entity or individual is submitting this Order or Notice.
- 1g. Identifying case number used by the entity or individual sending this Order or Notice. In a IV-D case, this must be the IV-D case number.

The following information in 2 and 3 refers to the obligor, obligor's employer, and case identification.

- 2a. Employer's/Withholder's name.

PUBLIC NECESSITY RULES

2b-c. Employer's/Withholder's mailing address, city, and state. (This may differ from the Employee's/Obligor's work site.)

2d. Employer's/Withholder's nine-digit federal employer identification number (if available). Include three-digit location code.

3a. Employee's/Obligor's last name, first name, and middle initial.

3b. Employee's/Obligor's Social Security Number (if known).

3c. The case identifier used by the order issuing state or tribe for recording payments. (Should be the same as #21.) In a IV-D case, this must be the IV-D case number.

3d. Custodial Parent's last name, first name, and middle initial (if known).

ORDER INFORMATION - The following information in 4 -14e refers to the dollar amounts taken directly from the child support order.

4. Name of the state or tribe that issued the support order.

5a-b. Dollar amount to be withheld for payment of current child support, time period that corresponds to the amount in #6a (such as month, week, etc.).

6a-b. Dollar amount to be withheld for payment of past-due child support, time period that corresponds to the amount in #6a (such as month, week, etc.).

7a-b. Dollar amount to be withheld for payment of current cash medical support, as appropriate, based on the underlying order, time period that corresponds to the amount in #7a (such as month, week, etc.).

8a-b. Dollar amount to be withheld for payment of past-due cash medical support, if appropriate, based on the underlying order and the time period that corresponds to the amount in #8a (such as month, week, etc.).

9a-b. Dollar amount to be withheld for payment of spousal support (alimony), if appropriate, based on the underlying order, time period that corresponds to the amount in #9a (such as month, week, etc.).

10a-b. Dollar amount to be withheld for payment of past-due spousal support (alimony), if appropriate, based on the underlying order, time period that corresponds to the amount in #10a (such as month, week, etc.).

11a-c. Dollar amount to be withheld for payment of miscellaneous obligations, if appropriate, based on the underlying order, time period that corresponds to the amount in #11a (e.g., month, week, etc.), and description of the miscellaneous obligation.

12a. Total of #5a, #6a, #7a, #8a, #9a, #10a, and # 11a.

12b. Time period that corresponds to the amount in #12a (e.g., month).

13. Check this box if arrears greater than 12 weeks.

14a. Amount an employer should withhold if the employee is paid weekly.

PUBLIC NECESSITY RULES

- 14b. Amount an employer should withhold if the employee is paid every two weeks.
- 14c. Amount an employer should withhold if the employee is paid twice a month.
- 14d. Amount an employer should withhold if the employee is paid once a month.

REMITTANCE INFORMATION

- 15. The state, tribe, or territory from which this Order/Notice or Notice of an Order is sent.
 - 16. Number of days in which the withholding must begin pursuant to the issuing state's or tribe's laws/procedures.
 - 17. The effective date of the income withholding.
 - 18. Number of working days within which an employer or other withholder of income must remit amounts withheld pursuant to the issuing state's law.
 - 19. The percentage of income that may be withheld from the employee's/obligor's income. For state orders, you may not withhold more than the lesser of: 1) the amounts allowed by the Federal Consumer Credit Protection Act (15 U.S.C. § 1673(b)); or 2) the amounts allowed by the state of the employee's/obligor's principal place of employment. The federal limit applies to the aggregate disposable weekly earnings (ADWE). ADWE is the net income left after making mandatory deductions such as: state, federal, local taxes, Social Security taxes, statutory pension contributions, and Medicare taxes.
For tribal orders, you may not withhold more than the amounts allowed under the law of the issuing tribe. For tribal employers who receive a state order, you may not withhold more than the amounts allowed under the law of the state that issued the order.
 - 20. The state, tribe, or territory from which the Order or Notice is sent.
 - 21. Name of the State Disbursement Unit, individual, tribunal/court, or tribal child support enforcement agency specified in the underlying income withholding order to which payments are required to be sent. This form may not indicate a location other than that specified by an entity authorized under state or tribal law to issue an income withholding order. Please include the case identifier used to record payment (should be the same as 3c). In a IV-D case, this must be the IV-D case number.
 - 22. Address of the State Disbursement Unit, tribunal/court, tribal child support enforcement agency, or individual identified in #21. This information is shared with the obligor. Be sure to safeguard confidential addresses.
- Complete only for EFT/EDI transmission.
- 23a. Telephone number of contact to provide EFT/EDI instructions.
 - 23b. Federal Information Process Standard (FIPS) code for transmitting payments through EFT/EDI. The FIPS code is five characters that identify the state, county or tribe. It is seven characters when it identifies the state, county, and a location within the county. It is necessary for centralized collections.
 - 23c. Receiving agency's bank routing number.
 - 23d. Receiving agency's bank account number.

PUBLIC NECESSITY RULES

IV-D agencies, courts, and attorneys (with authority to issue an income withholding order/notice) sending an Order/Notice to Withhold Income for Child Support must complete 24a-e.

24a. Print name of the government official authorizing this Order or Notice to Withhold.

24b. Print title of the government official authorizing this Order or Notice to Withhold.

24c. Signature of Government Official authorizing this Order/Notice to Withhold and date of signature. This line may be optional only if the Withholding Order/Notice includes the name and title of a government official (line 24a, 24b) and a signature of the official (line 24c) is not required by state or tribal law. Provide a signature if required by state or tribal law.

24d. Check the appropriate box to indicate whether a child support enforcement agency (IV-D) or court is authorizing this Order or Notice for withholding.

24e. Check the box if you are an attorney with authority to issue an order or notice under state law.

Attorneys, individuals, and private entities sending a Notice of an Order to Withhold Income for Child Support complete 25a-d.

25a. Print name of the individual or entity sending this Notice.

25b. Print title of the individual sending this Notice, if appropriate

25c. Signature of the individual sending this Notice and date of signature.

25d. Please check the appropriate box to indicate whether you are an attorney, individual, or private entity sending this Notice of an Order.

The following information refers to federal, state, or tribal laws that apply to issuing an income withholding order/notice or notice of an order to the employer. Any state or tribal specific information may be included in space provided.

26. Check the box if the state or tribal law requires the employer to provide a copy of the Order or Notice to the employee.

27. Use this space to provide additional information on the penalty and/or citation for an employer who fails to comply with the Order or Notice. The law of the obligor's principal place of employment governs the penalty.

28. Use this space to provide additional information on the penalty and/or citation for an employer, who discharges, refuses to employ, or disciplines an employee/obligor as a result of the Order or Notice. The law of the obligor's principal place of employment governs the penalty.

29. Use this space to provide the child (ren)'s names listed in the support order and/or additional information regarding this income withholding Order or Notice of an Order.

Please provide the following contact information to the employer. Employers may need additional information to process the Order or Notice.

30a. Name of the contact person sending the Order or Notice of an Order that an employer and/or employee/obligor may call for information regarding the Order or Notice of an Order.

PUBLIC NECESSITY RULES

30b. Telephone number for the contact person whose name appears in #30a.

30c. Fax number for the person whose name appears in #30a.

30d. Internet address for the person whose name appears in #30a.

If the employer is a Federal Government agency, the following instructions apply.

■ Serve the Order or Notice of an Order upon the governmental agent listed in 5 CFR part 581, appendix A.

■ Sufficient identifying information must be provided in order for the obligor to be identified. It is, therefore, recommended that the following information, if known and if applicable, be provided:

■ Full name of the obligor; (2) date of birth; (3) employment number, Department of Veterans Affairs claim number, or civil service retirement claim number; (4) component of the government entity for which the obligor works, and the official duty station or worksite; and (5) status of the obligor, e.g., employee, former employee, or annuitant.

■ You may withhold from a variety of incomes and forms of payment, including voluntary separation incentive payments (buy-out payments), incentive pay, and cash awards. For a more complete list see 5 CFR 581.103.

The Paperwork Reduction Act of 1995

This information collection is conducted in accordance with 45 CFR 303.100 of the child support enforcement program. Standard forms are designed to provide uniformity and standardization for interstate case processing. Public reporting burden for this collection of information is estimated to average one hour per response. The responses to this collection are mandatory in accordance with 45 CFR 303.7. This information is subject to State and Federal confidentiality requirements; however, the information will be filed with the tribunal and/or agency in the responding State and may, depending on State law, be disclosed to other parties. An agency may not conduct or sponsor, and a person is not required to respond to, a collection of information unless it displays a currently valid OMB control number.

Authority: T.C.A. §§ 4-5-202, 8-21-403, 36-5-116, 36-5-501, 71-1-132(c), 42 U.S.C. §§ 651, et seq., 42 U.S.C. §§ 652(a)(11), 654(9)(E), 654a(g)(1)(A)(ii) 654b(a) and 666(a)(8) and (b), 45 C.F.R. §§ 303.6(c)(1), 303.7, and 303.100; United States Department of Health and Human Services' Office of Child Support Enforcement Action Transmittal 04-05, July 15, 2004.

Rule 1240-2-2-.04, Order/Notice to Withhold Income for Child Support (Order for Income Assignment), is amended by deleting paragraph (8) in its entirety and by substituting instead the following language so that, as amended, paragraph (8) shall read as follows:

(8) The following blank form is provided for the user's convenience:

ORDER/NOTICE TO WITHHOLD INCOME FOR CHILD SUPPORT

NOTICE OF AN ORDER TO WITHHOLD INCOME FOR CHILD SUPPORT

ORIGINAL AMENDED TERMINATION

Date:

PUBLIC NECESSITY RULES

State/Tribe/Territory _____
 City/Co./Dist./Reservation _____
 Non-governmental entity or Individual _____
 Case Number

_____ Employer's/Withholder's Name	_____ Employee's/Obligor's Name (Last, First, MI)
_____ Employer's/Withholder's Address	_____ Employee's/Obligor's Social Security Number
_____ _____	_____ Employee's/Obligor's Case Identifier
_____ Employer's/Withholder's Federal EIN Number (if known)	_____ Obligee's Name (Last, First, MI)

ORDER INFORMATION: This document is based on the support or withholding order from _____ .
 You are required by law to deduct these amounts from the employee's/obligor's income until further notice.

\$ _____ Per _____ current child support
 Past-due child support – Arrears greater than 12 weeks? yes
no
 \$ _____ Per _____ current cash medical support
 past-due cash medical
 \$ _____ Per _____ support
 \$ _____ Per _____ spousal support
 \$ _____ Per _____ past-due spousal support
 \$ _____ Per _____ other (specify) _____
 for a total of \$ _____ per _____ to be forwarded to the payee below.

You do not have to vary your pay cycle to be in compliance with the support order. If your pay cycle does not match the ordered payment cycle, withhold one of the following amounts:

\$ _____ per weekly pay period.	\$ _____ per semimonthly pay period (twice a month).
\$ _____ per biweekly pay period (every two weeks).	\$ _____ per monthly pay period.

REMITTANCE INFORMATION: When remitting payment, provide the pay date/date of withholding and the case identifier. If the employee's/obligor's principal place of employment is Tennessee, begin withholding no later than the first pay period occurring 14 working days after the date of _____. Send payment within 7 working days of the pay date/date of withholding. The total withheld amount, including your fee, may not exceed 50% of the employee's/obligor's aggregate disposable weekly earnings.

If the employee's/obligor's principal place of employment is not Tennessee, for limitations on withholding, applicable time requirements, and any allowable employer fees, follow the laws and procedures of the employee's/obligor's principal place of employment (see #3 and # 9, ADDITIONAL INFORMATION TO EMPLOYERS AND OTHER WITHHOLDERS).

Make check payable to : _____ Send check to: _____

If remitting payment by EFT/EDI, call _____ before first submission. _____

Use this FIPS code: _____ Bank routing number: _____ Bank account number: _____

PUBLIC NECESSITY RULES

If this is an Order/Notice to Withhold:
 Print Name _____
 Title of Issuing Official _____
 Signature _____

If this is a Notice of an Order to Withhold:
 Print Name _____
 Title (if appropriate) _____
 Signature _____

Date _____
 IV-D Agency Court Attorney Individual
 Attorney with authority under state law to issue order/notice

Date _____
 Private Entity

NOTE: Non-IV-D Attorneys, individuals, and non-governmental entities must submit a Notice of an Order to Withhold and include a copy of the income withholding order unless, under a state's law, an attorney in that state may issue an income withholding order. In that case, the attorney may submit an Order/Notice to Withhold and include a copy of the state law authorizing the attorney to issue an income withholding order/notice.

IMPORTANT: The person completing this form is advised that the information on this form may be shared with the obligor.

OMB 0970-0154

ADDITIONAL INFORMATION TO EMPLOYERS AND OTHER WITHHOLDERS

If checked, you are required to provide a copy of this form to your employee/obligor. If your employee works in a state that is different from the state that issued this order, a copy must be provided to your employee/obligor even if the box is not checked.

1. **Priority:** Withholding under this Order or Notice has priority over any other legal process under state law (or tribal law, if applicable) against the same income. If there are federal tax levies in effect, please notify the contact person listed below. (See 10 below.)
2. **Combining Payments:** You may combine withheld amounts from more than one employee's/obligor's income in a single payment to each agency/party requesting withholding. You must, however, separately identify the portion of the single payment that is attributable to each employee/obligor.
3. **Reporting the Paydate/Date of Withholding:** You must report the paydate/date of withholding when sending the payment. The paydate/date of withholding is the date on which the amount was withheld from the employee's wages. You must comply with the law of the state of the employee's/obligor's principal place of employment with respect to the time periods within which you must implement the withholding and forward the support payments.
4. **Employee/Obligor with Multiple Support Withholdings:** If there is more than one Order or Notice against this employee/obligor and you are unable to honor all support Orders or Notices due to federal, state, or tribal withholding limits, you must follow the state or tribal law/procedure of the employee's/obligor's principal place of employment. You must honor all Orders or Notices to the greatest extent possible. (see 9 below.)
5. **Termination Notification:** You must promptly notify the Child Support Enforcement (IV-D) Agency and/or the contact person listed below when the employee/obligor no longer works for you. Please provide the information requested and return a complete copy of this Order or Notice to the Child Support Enforcement (IV-D) Agency and/or the contact person listed below. (See 10 below.)

THE EMPLOYEE/OBLIGOR NO LONGER WORKS FOR: _____
 EMPLOYEE'S/OBLIGOR'S NAME: _____ CASE IDENTIFIER: _____
 DATE OF SEPARATION FROM EMPLOYMENT: _____
 LAST KNOWN HOME ADDRESS: _____
 NEW EMPLOYER/ADDRESS: _____

6. **Lump Sum Payments:** You may be required to report and withhold from lump sum payments such as bonuses, commissions, or severance pay. If you have any questions about lump sum payments, contact the Child Support Enforcement (IV-D) Agency.

PUBLIC NECESSITY RULES

Employer's/Withholder's Federal EIN Number (if known) Employee's/Obligor's Case Identifier

Obligee's Name (Last, First, MI)

ORDER INFORMATION: This document is based on the support or withholding order from _____ .
You are required by law to deduct these amounts from the employee's/obligor's income until further notice.

\$ _____ Per _____ current child support
Past-due child support – Arrears greater than 12 weeks? yes
\$ _____ Per _____ no
\$ _____ Per _____ current cash medical support
past-due cash medical
\$ _____ Per _____ support
\$ _____ Per _____ spousal support
\$ _____ Per _____ past-due spousal support
\$ _____ Per _____ other (specify) _____
for a total of \$ _____ per _____ to be forwarded to the payee below.

You do not have to vary your pay cycle to be in compliance with the support order. If your pay cycle does not match the ordered payment cycle, withhold one of the following amounts:

\$ _____ per weekly pay period. \$ _____ per semimonthly pay period (twice a
month).
\$ _____ per biweekly pay period (every two weeks). \$ _____ per monthly pay period.

REMITTANCE INFORMATION: When remitting payment, provide the pay date/date of withholding and the case identifier. If the employee's/obligor's principal place of employment is Tennessee, begin withholding no later than the first pay period occurring 14 working days after the date of _____. Send payment within 7 working days of the pay date/date of withholding. The total withheld amount, including your fee, may not exceed 50% of the employee's/obligor's aggregate disposable weekly earnings.

If the employee's/obligor's principal place of employment is not Tennessee, for limitations on withholding, applicable time requirements, and any allowable employer fees, follow the laws and procedures of the employee's/obligor's principal place of employment (see #3 and # 9, ADDITIONAL INFORMATION TO EMPLOYERS AND OTHER WITHHOLDERS).

Make check payable to: _____ Send check to: _____

If remitting payment by EFT/EDI, call _____ before first submission. _____

Use this FIPS code: _____ Bank routing number: _____ Bank account number: _____

If this is an Order/Notice to Withhold:
Print Name _____
Title of Issuing Official _____
Signature _____

If this is a Notice of an Order to Withhold:
Print Name _____
Title (if appropriate) _____
Signature _____

Date _____
 IV-D Agency Court Attorney Individual
 Attorney with authority under state law to issue order/notice

Date _____
 Private Entity

NOTE: Non-IV-D Attorneys, individuals, and non-governmental entities must submit a Notice of an Order to Withhold and include a copy of the income withholding order unless, under a state's law, an attorney in that state may issue an income withholding order. In that case, the attorney may submit an Order/Notice to Withhold and include a copy of the state law authorizing the attorney to issue an income withholding order/notice.

PUBLIC NECESSITY RULES

IMPORTANT: The person completing this form is advised that the information on this form may be shared with the obligor.

OMB 0970-0154

ADDITIONAL INFORMATION TO EMPLOYERS AND OTHER WITHHOLDERS

☐ If checked, you are required to provide a copy of this form to your employee/obligor. If your employee works in a state that is different from the state that issued this order, a copy must be provided to your employee/obligor even if the box is not checked.

- 1. Priority: Withholding under this Order or Notice has priority over any other legal process under state law (or tribal law, if applicable) against the same income. If there are federal tax levies in effect, please notify the contact person listed below. (See 10 below.)
2. Combining Payments: You may combine withheld amounts from more than one employee's/obligor's income in a single payment to each agency/party requesting withholding. You must, however, separately identify the portion of the single payment that is attributable to each employee/obligor.
3. Reporting the Paydate/Date of Withholding: You must report the paydate/date of withholding when sending the payment. The paydate/date of withholding is the date on which the amount was withheld from the employee's wages. You must comply with the law of the state of the employee's/obligor's principal place of employment with respect to the time periods within which you must implement the withholding and forward the support payments.
4. Employee/Obligor with Multiple Support Withholdings: If there is more than one Order or Notice against this employee/obligor and you are unable to honor all support Orders or Notices due to federal, state, or tribal withholding limits, you must follow the state or tribal law/procedure of the employee's/obligor's principal place of employment. You must honor all Orders or Notices to the greatest extent possible. (see 9 below.)
5. Termination Notification: You must promptly notify the Child Support Enforcement (IV-D) Agency and/or the contact person listed below when the employee/obligor no longer works for you. Please provide the information requested and return a complete copy of this Order or Notice to the Child Support Enforcement (IV-D) Agency and/or the contact person listed below. (See 10 below.)

THE EMPLOYEE/OBLIGOR NO LONGER WORKS FOR:
EMPLOYEE'S/OBLIGOR'S NAME: _____ CASE IDENTIFIER: _____
DATE OF SEPARATION FROM EMPLOYMENT: _____
LAST KNOWN HOME ADDRESS: _____
NEW EMPLOYER/ADDRESS: _____

- 6. Lump Sum Payments: You may be required to report and withhold from lump sum payments such as bonuses, commissions, or severance pay. If you have any questions about lump sum payments, contact the Child Support Enforcement (IV-D) Agency.
7. Liability: If you have any doubts about the validity of the Order or Notice, contact the agency or person listed below under 10. If you fail to withhold income as the Order or Notice directs, you are liable for both the accumulated amount you should have withheld from the employee's/obligor's income and any other penalties set by state or tribal law/procedure.

- 8. Anti-discrimination: You are subject to a fine determined under state or tribal law for discharging an employee/obligor from employment, refusing to employ, or taking disciplinary action against any employee/obligor because of a child support withholding.

PUBLIC NECESSITY RULES

- 9. Withholding Limits: For state orders, you may not withhold more than the lesser of: 1) the amounts allowed by the Federal Consumer Credit Protection Act (15 U.S.C. §1673(b)); or 2) the amounts allowed by the state of the employee's/obligor's principal place of employment. The federal limit applies to the aggregate disposable weekly earnings (ADWE). ADWE is the net income left after making mandatory deductions such as: state, federal, local taxes, Social Security taxes, statutory pension contributions, and Medicare taxes. The Federal CCPA limit is 50% of the ADWE for child support and alimony, which is increased by 1) 10% if the employee does not support a second family; and /or 2) 5% if arrears greater than 12 weeks. For tribal orders, you may not withhold more than the amounts allowed under the law of the issuing tribe. For tribal employers who receive a state order, you may not withhold more than the amounts allowed under the law of the state that issued the order.

Child(ren)'s Names and Additional Information: _____

Tennessee Employers/Payers of Income should refer to the Department's Rule 1240-2-2-.05, available on the Internet at <http://www.state.tn.us/sos/rules/1240/1240-02/1240-02-02.pdf>, for state specific information about the priority and proration of payments if multiple Orders/Notices are received for one employee.

10. If you or your employee/obligor have any questions, _____ by telephone
contact: by Fax _____ or by Internet at @ _____ at _____
at _____

Authority: T.C.A. §§ 4-5-202, 8-21-403, 36-5-116, 36-5-501, 71-1-132(c), 42 U.S.C. §§ 651, et seq., 42 U.S.C §§ 652(a)(11), 654(9)(E), 654a(g)(1)(A)(ii) 654b(a) and 666(a)(8) and (b), 45 C.F.R. §§ 303.6(c)(1), 303.7, and 303.100; United States Department of Health and Human Services' Office of Child Support Enforcement Action Transmittal 04-05, July 15, 2004.

The public necessity rules set out herein were properly filed in the Department of State on the 20th day of May, 2005, and will be effective from the date of filing for a period of 165 days. These public necessity rules will remain in effect through the 1st day of November, 2005. (05-20)

PUBLIC NECESSITY RULES

TENNESSEE DEPARTMENT OF HUMAN SERVICES - 1240
Child Support Services Division

Statement of Necessity Requiring Public Necessity Rules

Under federal and state law, 42 U.S.C. § 666(a)(4) and Tennessee Code Annotated § 36-5-901(a)(1), a lien arises by operation of the law against all real and personal property of an obligor who is delinquent in the payment of his/her child support obligation. The notice of lien form to be used for this purpose was implemented by the Department, according to federal requirements, in Rule 1240-2-5-.16.

Periodically, the federal Department of Health and Human Services, through the federal Office of Child Support Enforcement (OCSE), will make changes to the notice of lien form which must be adopted by the Department as soon as practicable thereafter. OCSE has recently made such changes. In order to maintain compliance with federal requirements, Tennessee Code Annotated § 71-1-132(c) permits the Department to implement these changes through public necessity rules.

For a copy of this public necessity rule, contact Darryl F. Wells, Legal Assistant, Citizens Plaza Building, 15th Floor, 400 Deaderick Street, Nashville, Tennessee 37248-0006 (615) 313-4731.

Virginia T. Lodge
Commissioner
Tennessee Department of Human Services

PUBLIC NECESSITY RULES
OF
TENNESSEE DEPARTMENT OF HUMAN SERVICES
CHILD SUPPORT SERVICES DIVISION

CHAPTER 1240-2-5

LIENS FOR CHILD SUPPORT

AMENDMENTS

Rule 1240-2-5-.16, Child Support Lien Notice and Instructions, is amended by deleting paragraph (3) in its entirety.

Authority: *T.C.A. §§ 4-5-202; 36-5-901, et seq.; 36-5-912, 42 U.S.C. §§ 652, 654(9)(E) and 666; United States Department of Health and Human Services' Office of Child Support Enforcement Action Transmittal 01-06, April 4, 2001, and Action Transmittal 05-04, January 4, 2005.*

Rule 1240-2-5-.16, Child Support Lien Notice and Instructions, is amended by deleting subparagraph (a) of paragraph (1) in its entirety and by substituting instead the following language so that, as amended, subparagraph (a) shall read as follows:

- (a) The Department or its contractors in the Title IV-D program may use the form in paragraph (2) as necessary to give notice of the existence of the lien in intrastate cases, or, in interstate cases as provided by Federal law. The form contains instructions for its use.

PUBLIC NECESSITY RULES

Authority: T.C.A. §§ 4-5-202; 36-5-901, et seq.; 36-5-912, 42 U.S.C. §§ 652, 654(9)(E) and 666; United States Department of Health and Human Services' Office of Child Support Enforcement Action Transmittal 01-06, April 4, 2001, and Action Transmittal 05-04, January 4, 2005.

Rule 1240-2-5-.16, Child Support Lien Notice and Instructions, is amended by deleting paragraph (2) in its entirety and by substituting instead the following:

(2) Form.



STATE OF TENNESSEE
DEPARTMENT OF HUMAN SERVICES

Fax

Type Name here
Address
City, State Zip

NOTICE OF LIEN

OBLIGOR:

OBLIGEE:

IV-D CASE #:

This lien results from a child support order, entered on ___ / ___ / ___ by _____ in _____ County, TN, Tribunal Number _____.

As of ___ / ___ / ___, the obligor owes unpaid support in the amount of \$ _____. This judgment may be subject to interest.

Prospective amounts of child support, not paid when due, are judgments that are added to the lien amount. This lien attaches to all non-exempt real and/or personal property of the above-named obligor which is located or existing within the State/county of filing, including any property specifically described below.

Specific description of property:

PUBLIC NECESSITY RULES

All aspects of this lien, including its priority and enforcement, are governed by the law of the State where the property is located. An obligor must follow the laws and procedures of the State where the property is located or recorded. An obligor may also contact the entity sending the lien. This lien remains in effect until released or withdrawn by the obligee or in accordance with the laws of the State where the property is located.

Note to Lien Recorder: Please provide the sender with a copy of the filed lien, containing the recording information, at the address provided above.

Check either "A" or "B" below. The option that does not apply may be omitted from the form. If "B" is checked, the form must be notarized.

A. Submitted by a IV-D agency/office on behalf of the named obligee

As an authorized agent of a State or Tribal, or subdivision of a State or Tribal, agency responsible for implementing the child support enforcement program set forth in Title IV, Part D, of the Federal Social Security Act (42 U.S.C. 651 et seq.), I have authority to file this child support lien in any State, or U.S. Territory. For additional information regarding this lien, including the pay-off amount, please contact the authorized agency and reference its case number, both listed above.

Date

Authorized Agent

Print name, e-mail address, phone and fax number

B. Submitted by an obligee or a private (non-IV-D) attorney or entity on behalf of an obligee.

I am:

the obligee of the above referenced order [or]

an attorney or entity representing the above named obligee.

I certify, under penalty of perjury, that the information contained in this notice is true and accurate and that this lien is submitted in accordance with the laws of the State of Tennessee. For additional information regarding this lien, including the pay-off amount, please contact the obligee listed above.

PUBLIC NECESSITY RULES

Date

Signature

Print name, e-mail address, phone and fax number

Notary State: _____

County: _____

I certify that _____ appeared before me and is known to me as the individual who signed the above.

Date: _____

Notary Public

My appointment expires _____

Notice: Respondents are not required to respond to this information collection unless it displays a valid OMB control number. The average burden for responding to this information collection is estimated at 30 minutes. If you believe this estimate is inaccurate, or if you have ideas to reduce this burden, please provide comment to the issuing agency.

OMB Control #: 0970-0153 Expiration Date: 01/31/2008

Instructions for the Notice of Lien

Purpose of This Form: 42 USC 654(9)(E) requires all IV-D programs to use the Notice of Lien form in interstate cases. IV-D programs may also use the form to impose liens in intrastate cases. This form may also be used for non-IV-D orders by an obligee or his or her private attorney. This form may be used to assert liens on assets discovered through the Financial Institution Data Match process. Please note that the expiration date on this form is the Office of Management and Budget expiration date, not the expiration date of the lien itself.

PUBLIC NECESSITY RULES

Whose Laws Apply?: All aspects of this lien, including its priority and enforcement, are governed by the law of the State where the property is located. Issue the lien to secure debts for past-due support upon identifying, in another State, nonexempt real or personal property belonging to the obligor. The laws and procedures of the State where the property is located or recorded determine which office or entity in that State is the appropriate one to receive the lien for filing. It is the responsibility of the agency/office or private attorney issuing the lien to file it with the appropriate entity.

Release of Lien: To release a previously-filed lien (e.g., upon receipt of full payment, or partial payment with an acceptable agreement to repay remaining balance, etc.) the original issuing State shall use its existing local release of lien form. A copy of the release of lien should be provided to the obligor. Identify the lien to be released by including the recording information provided by the office or entity that filed the lien (Lien Recorder). The laws and procedures of the State where the lien is filed control the release of the lien.

To complete this form:

1. At the top of the form, place the name, address, and fax number of the recorder (i.e., County Auditor, Clerk of Court, DMV, etc.) or asset holder (i.e., Financial Institution, Estate Executor, Trustee, etc.) to which you are sending the lien.

NOTE: The procedures of the State where the property is located determine which person or entity in that State is the appropriate one to receive the lien for filing. It is the responsibility of the person/entity/agency submitting the lien to file/serve it correctly.

2. In the "OBLIGOR" field place the obligor's full name, address, date of birth (if known) and social security number (if known). Include known aliases or multiple social security numbers used by the obligor.

3. In the "OBLIGEE" field insert the obligee's full name. Note that the obligee may be the individual obligee, a public IV-D agency, or a private attorney, person or entity with a proper assignment from the individual obligee.

4. In the "IV-D Case #" field, enter the number/identifier identical to the one submitted on the Federal Case Registry, which is a left-justified 15-character alphanumeric field, allowing all characters except asterisk and backslash, and with all characters in uppercase.

5. In the space following "entered on", insert the date of entry of the order that is the basis for the lien.

6. In the space following "by", identify the tribunal that issued the support order that is being used to determine the amount of the lien. A tribunal is a court, administrative agency, or quasi-judicial entity that has the authority to establish, enforce, and modify child support obligations.

7. In the space following "in", identify the location (State/county) of the tribunal that issued the support order that is being used to determine the amount of the lien.

8. In the space following "tribunal number", identify the tribunal docket, jacket or file number of the support order that is used to determine the amount of the lien.

9. In the space following "As of", insert the date of the debt calculation that is used in determining the amount of the lien.

10. In the space following "amount of \$", insert the lien amount (the amount of the past-due support obligation owed when the lien is prepared). Interest may be included in the lien amount if permitted under the law of the State where the lien is filed.

PUBLIC NECESSITY RULES

11. In the space following "Specific description of property", identify any specific property that you want the lien to attach to. Use the legal description of real property and, when the target of the lien is personal property, always provide the most specific identifying information available, including the location of the property, if known. (For example, include the make/model/year/appropriate registration numbers (if known), as opposed to referring to such personal property as "farm equipment"). For Financial Institutions, list the account numbers.

12. Check "A" if the lien is submitted by a IV-D agency and check "B" if the lien is submitted by an obligee or his or her private attorney.

13. Provide the date the lien is signed on the line provided above "date".

14. If "A" is checked, the appropriate individual should sign the lien on the line above "Authorized Agent". Type or print the name of the agent signing the lien below their signature. Include the agent's name, e-mail address (if available) and phone and fax numbers. If "A" is checked, the form does not need to be notarized. Note that, in IV-D cases, the pay-off amount will be available only from the IV-D agency.

15. If "B" is checked, the appropriate individual should sign the lien on the line above the two check boxes and should check the appropriate box. Type or print the name of the person signing the lien below their signature. Include the person's name, e-mail address (if available) and phone and fax numbers.

16. If "B" is checked, the signature of the party signing the lien must be notarized.

17. In the spaces following "Notary State" and "County", insert the name of the State and County (if applicable) where the notary is commissioned.

18. Send a copy of the lien to the obligor at his/her last known address.

Authority: T.C.A. §§ 4-5-202; 36-5-901, et seq.; 36-5-912, 42 U.S.C. §§ 652, 654(9)(E) and 666; United States Department of Health and Human Services' Office of Child Support Enforcement Action Transmittal 01-06, April 4, 2001, and Action Transmittal 05-04, January 4, 2005.

The public necessity rules set out herein were properly filed in the Department of State on the 20th day of May, 2005, and will be effective from the date of filing for a period of 165 days. These public necessity rules will remain in effect through the 1st day of November, 2005. (05-21)

RULEMAKING HEARINGS

BOARD FOR PROFESSIONAL COUNSELORS, MARITAL AND FAMILY THERAPISTS, AND CLINICAL PASTORAL THERAPISTS - 0450

There will be a hearing before the Tennessee Board for Professional Counselors, Marital and Family Therapists, and Clinical Pastoral Therapists to consider the promulgation of an amendment to a rule pursuant to T.C.A. §§ 4-5-202, 4-5-204, and 63-22-102. The hearing will be conducted in the manner prescribed by the Uniform Administrative Procedures Act, Tennessee Code Annotated, Section 4-5-204 and will take place in the Cumberland Room of the Cordell Hull Building located at 425 Fifth Avenue North, Nashville, TN at 2:30 p.m. (CDT) on the 15th day of August, 2005.

Any individuals with disabilities who wish to participate in these proceedings (review these filings) should contact the Department of Health, Division of Health Related Boards to discuss any auxiliary aids or services needed to facilitate such participation or review. Such initial contact may be made no less than ten (10) days prior to the scheduled meeting date (the date such party intends to review such filings), to allow time for the Division to determine how it may reasonably provide such aid or service. Initial contact may be made with the ADA Coordinator at the Division of Health Related Boards, First Floor, Cordell Hull Building, 425 Fifth Avenue North, Nashville, TN 37247-1010, (615) 532-4397.

For a copy of the entire text of this notice of rulemaking hearing contact:

Jerry Kosten, Regulations Manager, Division of Health Related Boards, 425 Fifth Avenue North, First Floor, Cordell Hull Building, Nashville, TN 37247-1010, (615) 532-4397.

SUBSTANCE OF PROPOSED RULE

AMENDMENT

Rule 0450-2-.04, Qualifications for Licensure, is amended by deleting subpart (1) (c) 2. (vii) in its entirety and substituting instead the following language, so that as amended, the new subpart (1) (c) 2. (vii) shall read:

- (1) (c) 2. (vii) Supervised practicum/internship of no less than three hundred (300) hours which includes experience in the assessment, diagnosis, and treatment of cognitive, affective and behavioral problems or dysfunctions in the DSM IV T.R. (or its successor) nomenclature, pursuant to T.C.A. § 63-22-106.

Authority: T.C.A. §§ 4-5-202, 4-5-204, 63-22-102, 63-22-103, 63-22-106, and 63-22-107.

The notice of rulemaking set out herein was properly filed in the Department of State on the 20th day of May, 2005. (05-22)

RULEMAKING HEARINGS

BOARD OF CHIROPRACTIC EXAMINERS - 0260

There will be a hearing before the Tennessee Board of Chiropractic Examiners to consider the promulgation of an amendment to a rule pursuant to T.C.A. §§ 4-5-202, 4-5-204, 63-4-106, 63-4-112, and Public Chapter 81 of the Public Acts of 2005. The hearing will be conducted in the manner prescribed by the Uniform Administrative Procedures Act, Tennessee Code Annotated, Section 4-5-204 and will take place in Conference Room 133 on the First Floor of the Cordell Hull Building located at 425 Fifth Avenue North, Nashville, TN at 2:30 p.m. (CDT) on the 4th day of August, 2005.

Any individuals with disabilities who wish to participate in these proceedings (review these filings) should contact the Department of Health, Division of Health Related Boards to discuss any auxiliary aids or services needed to facilitate such participation or review. Such initial contact may be made no less than ten (10) days prior to the scheduled meeting date (the date such party intends to review such filings), to allow time for the Division to determine how it may reasonably provide such aid or service. Initial contact may be made with the ADA Coordinator at the Division of Health Related Boards, First Floor, Cordell Hull Building, 425 Fifth Avenue North, Nashville, TN 37247-1010, (615) 532-4397.

For a copy of the entire text of this notice of rulemaking hearing contact:

Jerry Kosten, Regulations Manager, Division of Health Related Boards, 425 Fifth Avenue North, First Floor, Cordell Hull Building, Nashville, TN 37247-1010, (615) 532-4397.

SUBSTANCE OF PROPOSED RULE

AMENDMENT

Rule 0260-2-.12 Continuing Education, is amended by deleting paragraph (1) but not its subparagraphs and substituting instead the following language, and is further amended by deleting subparagraph (2) (a) and part (7) (a) 2. in their entirety and substituting instead the following language, so that as amended, the new paragraph (1) but not its subparagraphs, the new subparagraph (2) (a), and the new part (7) (a) 2. shall read:

- (1) Basic requirements - The Board of Chiropractic Examiners requires each licensee to complete twenty-four (24) clock hours of Board-approved continuing education each calendar year (January 1 – December 31).
- (2) (a) A six (6) hour Board approved course in risk management, sexual/professional boundaries, and Tennessee statutory and regulatory chiropractic jurisprudence shall constitute part of the twenty-four (24) clock hour continuing education requirement in paragraph (1) of this rule for the first calendar year that continuing education is required.
- (7) (a) 2. Any individual requesting reactivation of a license which has been retired for more than one (1) year must submit, along with the reactivation request, verification which indicates the attendance and completion of twenty-four (24) hours of continuing education for the year in which the license is to be reactivated. The continuing education hours must have been begun and successfully completed before the date of reactivation.

Authority: T.C.A. §§ 4-5-202, 4-5-204, 63-4-106, 63-4-112, and Public Chapter 81 of the Public Acts of 2005.

RULEMAKING HEARINGS

The notice of rulemaking set out herein was properly filed in the Department of State on the 13th day of May, 2005. (05-12)

RULEMAKING HEARINGS

BOARD OF DENTISTRY - 0460

There will be a hearing before the Tennessee Board of Dentistry to consider the promulgation of amendments to rules pursuant to T.C.A. §§ 4-5-202, 4-5-204, and 63-5-105. The hearing will be conducted in the manner prescribed by the Uniform Administrative Procedures Act, Tennessee Code Annotated, Section 4-5-204 and will take place in the Cumberland Room of the Cordell Hull Building located at 425 Fifth Avenue North, Nashville, TN at 2:30 p.m. (CDT) on the 21st day of July, 2005.

Any individuals with disabilities who wish to participate in these proceedings (review these filings) should contact the Department of Health, Division of Health Related Boards to discuss any auxiliary aids or services needed to facilitate such participation or review. Such initial contact may be made no less than ten (10) days prior to the scheduled meeting date (the date such party intends to review such filings), to allow time for the Division to determine how it may reasonably provide such aid or service. Initial contact may be made with the ADA Coordinator at the Division of Health Related Boards, First Floor, Cordell Hull Building, 425 Fifth Avenue North, Nashville, TN 37247-1010, (615) 532-4397.

For a copy of the entire text of this notice of rulemaking hearing contact:

Jerry Kosten, Regulations Manager, Division of Health Related Boards, 425 Fifth Avenue North, First Floor, Cordell Hull Building, Nashville, TN 37247-1010, (615) 532-4397.

SUBSTANCE OF PROPOSED RULES

AMENDMENTS

Rule 0460-1-.05, Continuing Education, is amended by deleting subpart (3) (d) 1. (x) in its entirety and substituting instead the following language, and is further amended by adding the following language as new subparts (3) (d) 1. (xi) and (3) (d) 1. (xii), so that as amended, the new subparts (3) (d) 1. (x), (3) (d) 1. (xi), and (3) (d) 1. (xii) shall read:

(3) (d) 1. (x) Tennessee Department of Health and its affiliated Metropolitan Health Departments, those being the Chattanooga/Hamilton County Health Department, the Davidson County Health Department, the Jackson-Madison County Health Department, the Knox County Health Department, Memphis the Shelby County Health Department, and the Sullivan County Health Department.

(3) (d) 1. (xi) Tennessee Emergency Management Agency (TEMA).

(3) (d) 1. (xii) Federal Emergency Management Agency (FEMA).

Authority: T.C.A. §§ 4-5-202, 4-5-204, 63-5-105, and 63-5-107.

Rule 0460-2-.03 (2), Limited and Educational Limited Licensure Process, is amended by deleting subparagraph (2) (f) in its entirety and substituting instead the following language, and is further amended by adding the following language as new subparagraph (2) (g), so that as amended, the new subparagraphs (2) (f) and (2) (g) shall read:

RULEMAKING HEARINGS

- (2) (f) Shall submit when applying for licensure and when applying for renewal of licensure, if practice is to be in a federally-designated health professional shortage area, proof of employment as a dentist or proof of starting/maintaining a private dental practice; and
- (2) (g) If the applicant has ever taken any regional testing agency examination or any other Board-approved examination as provided in rule 0460-2-.05, an application will not be approved unless and/or until a certification is submitted which indicates that the applicant achieved passing scores on all parts of the examination.

Authority: T.C.A. §§ 4-5-202, 4-5-204, 63-5-105, 63-5-110, and 63-5-111.

Rule 0460-2-.06, Specialty Certification, is amended by deleting paragraph (14) in its entirety.

Authority: T.C.A. §§ 4-5-202, 4-5-204, and 63-5-105.

Rule 0460-2-.07, Anesthesia and Sedation, is amended by deleting parts (6) (a) 1. and (6) (a) 2. but not their subparts, and substituting instead the following language, and is further amended by deleting subpart (7) (a) 1. (i) but not its items, and substituting instead the following language, so that as amended, the new parts (6) (a) 1. and (6) (a) 2. but not their subparts, and the new subpart (7) (a) 1. (i) but not its items shall read:

- (6) (a) 1. To obtain a limited conscious sedation permit, a dentist must provide proof of current certification in ACLS (a pediatric dentist may substitute PALS), and must provide proof of one (1) of the following:
- (6) (a) 2 . To obtain a comprehensive conscious sedation permit, a dentist must provide proof of current certification in ACLS (a pediatric dentist may substitute PALS), and must provide proof of one (1) of the following:
- (7) (a) 1. (i) To obtain a deep sedation/general anesthesia permit, a dentist must provide proof of current certification in ACLS (a pediatric dentist may substitute PALS), and must provide certification of one (1) of the following:

Authority: T.C.A. §§ 4-5-202, 4-5-204, 63-5-105, and 63-5-108.

The notice of rulemaking set out herein was properly filed in the Department of State on the 13th day of May, 2005. (05-13)

RULEMAKING HEARINGS

BOARD OF ELECTROLYSIS EXAMINERS - 0540

There will be a hearing before the Tennessee Board of Electrolysis Examiners to consider the promulgation of amendments to rules pursuant to T.C.A. §§ 4-5-202, 4-5-204, and 63-26-108. The hearing will be conducted in the manner prescribed by the Uniform Administrative Procedures Act, Tennessee Code Annotated, Section 4-5-204 and will take place in the Cumberland Room of the Cordell Hull Building located at 425 Fifth Avenue North, Nashville, TN at 2:30 p.m. (CDT) on the 31st day of August, 2005.

Any individuals with disabilities who wish to participate in these proceedings (review these filings) should contact the Department of Health, Division of Health Related Boards to discuss any auxiliary aids or services needed to facilitate such participation or review. Such initial contact may be made no less than ten (10) days prior to the scheduled meeting date (the date such party intends to review such filings), to allow time for the Division to determine how it may reasonably provide such aid or service. Initial contact may be made with the ADA Coordinator at the Division of Health Related Boards, 1st Floor, Cordell Hull Building, 425 Fifth Avenue North, Nashville, TN 37247-1010, (615) 532-4397.

For a copy of the entire text of this notice of rulemaking hearing contact:

Jerry Kosten, Regulations Manager, Division of Health Related Boards, 425 Fifth Avenue North, First Floor, Cordell Hull Building, Nashville, TN 37247-1010, (615) 532-4397.

SUBSTANCE OF PROPOSED RULES

AMENDMENTS

Rule 0540-1-.04, Qualifications for Licensure, is amended by deleting part (1) (c) 3. in its entirety and substituting instead the following language, so that as amended, the new part (1) (c) 3. shall read:

- (1) (c) 3. Successful completion of general (college level) education courses which shall not include remedial and developmental courses, for at least the following specified number of semester hours:

Course	# of Semester Hours
(i) Communications: English Composition I	3
(ii) Humanities and/or Fine Arts	3
(iii) Anatomy and Physiology	8
(iv) Social and/or Behavioral Sciences	3
Total	17

Authority: T.C.A. §§ 4-5-202, 4-5-204, 63-26-108, 63-26-111, and 63-26-112.

Rule 0540-1-.05, Procedures for Licensure, is amended by adding the following language as new paragraph (19) and renumbering the remaining paragraphs accordingly:

RULEMAKING HEARINGS

- (19) An applicant shall cause to be submitted to the Board's administrative office directly from the vendor identified in the Board's licensure application materials, the result of a criminal background check.

Authority: T.C.A. §§ 4-5-202, 4-5-204, 63-26-108, and 63-26-123.

Rule 0540-1-.06, Fees, is amended by deleting subparagraph (1) (d) in its entirety and substituting instead the following language, so that as amended, the new subparagraph (1) (d) shall read:

- (1) (d) License fee - A non-refundable fee to be paid by all applicants, except those seeking licensure by reciprocity, prior to the issuance of the initial license.

Authority: T.C.A. §§ 4-5-202, 4-5-204, 63-26-108, and 63-26-109.

Rule 0540-1-.07, Application Review, Approval, and Denial, is amended by deleting paragraph (4) in its entirety and substituting instead the following language, so that as amended, the new paragraph (4) shall read:

- (4) If an application is incomplete when received by the Board's administrative office, or if the Board's administrator determines additional information is required from an applicant before an initial determination can be made, the Board's administrative office shall notify the applicant of the information required.
- (a) The applicant shall cause the requested information to be received by the Board's administrative office on or before the sixtieth (60th) day after the notification requesting such information is sent to the applicant.
- (b) If requested information is not timely received, the application file may be considered abandoned and may be closed by the Board's administrator. If that occurs, the applicant shall be notified that the Board will not consider issuance of a license until a new application is received pursuant to the rules governing that process, including another payment of all fees applicable to the applicant's circumstances and submission of such new supporting documents as is required by the Board or the Board's administrator.

Authority: T.C.A. §§ 4-5-202, 4-5-204, 63-26-108, 63-26-109, 63-26-111, 63-26-112, and 63-26-119.

Rule 0540-3-.04, Standards for License, is amended by deleting subparagraph (4) (b) in its entirety and substituting instead the following language, so that as amended, the new subparagraph (4) (b) shall read:

- (4) (b) General (college level) education courses which shall not include remedial and developmental courses, for at least the following specified number of semester hours:

Course	# of Semester Hours
1. Communications: English Composition I	3
2. Humanities and/or Fine Arts	3
3. Anatomy and Physiology	8

RULEMAKING HEARINGS

4.	Social and/or Behavioral Sciences	3
	Total	17

Authority: T.C.A. §§ 4-5-202, 4-5-204, 63-26-108, and 63-26-119.

The notice of rulemaking set out herein was properly filed in the Department of State on the 20th day of May, 2005. (05-19)

RULEMAKING HEARINGS

**DEPARTMENT OF ENVIRONMENT AND CONSERVATION - 0400
DIVISION OF GROUND WATER PROTECTION**

There will be a series of hearings before the Tennessee Department of Environment and Conservation to consider the promulgation of amendments of rules pursuant to Tennessee Code Annotated 68-221-403(a)(2). These hearings will be conducted in the manner prescribed by the Uniform Administrative Procedures Act, Tennessee Code Annotated, Section 4-5-204 and will take place as follows:

August 9, 2005 at 1:00 PM (CST)
Jackson Environmental Assistance Center
Conference Room A
362 Carriage Drive
Jackson, Tennessee 38305

August 11, 2005 at 1:30 PM (EST)
Knoxville Environmental Assistance Center
East Side Conference Room
2700 Middlebrook Pike, Suite 220
Knoxville, Tennessee 37921

August 15, 2005 at 12:00 PM (CST)
17th Floor, L & C Tower
Conference Room B
Nashville, Tennessee 37243-1540

Written comments will be considered if received by close of business, August 31, 2005 at the Division of Ground Water Protection, 10th Floor, L & C Tower, 401 Church Street, Nashville, TN 37243-1540.

Any individuals with disabilities who wish to participate in these proceedings (to review these filings) should contact the Tennessee Department of Environment and Conservation to discuss any auxiliary aids or services needed to facilitate such participation. Such initial contact may be made no less than ten (10) days prior to the scheduled meeting date (the date the party intends to review such findings), to allow time for the Department of Environment and Conservation to determine how it may reasonably provide such aid or service. Initial contact may be made with the Department of Environment and Conservation's ADA Coordinator at L & C Annex, 7th Floor, 401 Church Street, Nashville, TN 37243-0437 and (615) 532-0059.

For a copy of this notice of rulemaking hearing contact Mr. Dan E. Hoover, Tennessee Department of Environment and Conservation, 10th Floor, L & C Tower, 401 Church Street, Nashville, TN 37243-1540 and (615) 532-0772. Copies of draft rules are available for review at the following locations:

Johnson City Environmental Assistance Center
2305 Silverdale Road
Johnson City, TN 37601-2162

Knoxville Environmental Assistance Center
2700 Middlebrook Pike, Suite 220
Knoxville, TN 37921

RULEMAKING HEARINGS

Chattanooga Environmental Assistance Center
540 McCallie Avenue, Suite 550
Chattanooga, TN 37402-2013

Cookeville Environmental Assistance Ctr.
1221 South Willow Avenue
Cookeville, TN 38506

Nashville Environmental Assistance Center
711 R.S. Gass Bldg.
Nashville, TN 37243

Columbia Environmental Assistance Center
2484 Park Plus Drive
Columbia, TN 38401

Jackson Environmental Assistance Center
362 Carriage House Drive
Jackson, TN 38305

Division of Ground Water Protection
10th Floor, L & C Tower
401 Church Street
Nashville, TN 37243-1540

RULES OF DEPARTMENT OF ENVIRONMENT AND CONSERVATION DIVISION OF GROUND WATER PROTECTION

CHAPTER 1200-1-6 REGULATIONS TO GOVERN SUBSURFACE SEWAGE DISPOSAL SYSTEMS

AMENDMENTS

Rules 1200-1-6-.01 through 1200-1-6-.22, Regulations To Govern Subsurface Sewage Disposal Systems, are amended by deleting them in their entirety and substituting the following to read as follows:

TABLE OF CONTENTS

1200-1-6-.01	Definitions		
1200-1-6-.02	Subdivisions	1200-1-6-.16	Privies and Composting Toilets
1200-1-6-.03	Additional Site Requirements and Limitations for Subdivision Approval And Issuance of Construction Permit		
1200-1-6-.04	Percolation Test Procedures	1200-1-6-.17	Approved Soil Consultants
1200-1-6-.05	Construction Permit		
1200-1-6-.06	Design of Conventional Disposal Field	1200-1-6-.18	Installer of Subsurface Sewage Disposal Systems
1200-1-6-.07	Septic Tank Capacity		
1200-1-6-.08	Design of Septic Tanks	1200-1-6-.19	Septic Tank Pumping Contractor
1200-1-6-.09	Effluent Treatment Devices/Systems		
1200-1-6-.10	Location of Septic Tanks, Dosing Chambers and Absorption Fields	1200-1-6-.20	Domestic Septage Disposal
1200-1-6-.11	Design of Dosing Systems	1200-1-6-.21	Fees for Services
1200-1-6-.12	Maintenance of the Subsurface Sewage Disposal System	1200-1-6-.22	General Provisions
1200-1-6-.13	Grease Traps		
1200-1-6-.14	Alternative Methods of Subsurface Sewage Disposal		
1200-1-6-.15	Experimental Methods of Treatment and Disposal other Than Those in These Regulations		

RULEMAKING HEARINGS

1200-1-6-.01 DEFINITIONS.

Accessible Community Sewer means a public sewer system not limited for use because of physical or other features as determined by the Commissioner.

Alternative/Experimental Methods of Disposal means a subsurface sewage disposal system, the construction, installation and operation of which varies from that of a conventional subsurface sewage disposal system.

Blockout means a potential access hole which is a thin section of concrete preformed in a septic tank which can be removed to allow insertion of a four (4) to six (6) inch diameter pipe.

Boundary Outline means a map or chart with lines delineating the boundaries of the proposed area or parcel of land.

Buffer Zone means the distance between subsurface sewage disposal systems or subsystems required to alleviate the impact of hydraulic overloading from the adjacent system(s).

Commissioner means the Commissioner of the Department of Environment and Conservation, his duly authorized representative, and in the event of his absence or a vacancy in the Office of Commissioner, the Deputy Commissioner.

Conventional Sand Filter means a filter with two (2) feet or more of medium sand designed to chemically and biologically process septic tank or other treatment unit effluent from a pressure distribution system operated on an intermittent basis.

Conventional Subsurface Sewage Disposal System means a system that pretreats sewage by use of a septic tank and applies effluent to the soil as described in Rule 1200-1-6-.06.

Department means the Tennessee Department of Environment and Conservation.

Disposal Field means the part of a subsurface sewage disposal system that utilizes the soil for absorption and treatment of septic tank effluent.

Domestic Septage means either liquid or solid material removed from a septic tank, cesspool, portable toilet, Type III marine sanitation device, or similar treatment works that receive only domestic sewage. Domestic septage does not include liquid or solid material removed from a septic tank, cesspool, or similar treatment works that receives either commercial wastewater or industrial wastewater and does not include grease removed from a grease trap at a restaurant.

Dosing Chamber means a watertight receptacle which houses a sewage effluent pump and stores sewage effluent from a septic tank until it is pumped to a disposal field.

Effluent Filter means an effluent treatment device installed on the outlet of a septic tank or dosing tank which is designed to prevent the passage of large suspended matter.

Filled Land means areas to which more than two (2) feet of soil and/or debris have been added.

Graded Land means areas from which soil has been removed and the remaining soil cannot be classified in any soil series.

RULEMAKING HEARINGS

Grease means animal fats or vegetable oils (resulting from food preparation) which are discharged to a sewage disposal system or accumulated in collection devices or traps that are associated with sewage disposal systems, conduits, sewers, plumbing fixtures and attachments. However, this definition shall exclude petroleum products, lubricants, silicones and greases of mineral or synthetic origin.

Grease Trap means a device designed to intercept and retain grease present in sewage or other wastewater.

Gullied Land means areas where gullies occupy nearly all of the surface area. Areas in which gullies occur within spacial intervals of less than one hundred (100) feet shall be classified as a soil gullied land complex. Gullies of more than one hundred (100) feet spatial intervals shall be located on the soil maps with the designated symbols.

Gully means a miniature valley (more than one foot in depth) cut by running water and through which water generally runs during and shortly after rainfall. Gullies are intermittent stream channels.

Installer of Subsurface Sewage Disposal Systems means a person who contracts or otherwise installs, constructs, alters or extends a subsurface sewage disposal system.

Lot means a part of a subdivision or a parcel of land intended for the building of a single house, building, or other development where a subsurface sewage disposal system is to be used.

Miscellaneous Land Types means areas on the earth's surface that are non-soil (rocks, water, etc) and soils that are difficult or impossible to classify in soil series (filled land, graded land, gullied land, paved areas, etc.)

Percolation Rate means the rate at which water moves into the soil as determined by a percolation test.

Percolation Test means a method of determining the usability of an area for subsurface sewage disposal by testing for the rate at which the undisturbed soil in a series of test holes of standard size will absorb water per unit of surface area.

Person means any and all persons, including individuals, firms, partnerships, associations, public or private institutions, municipalities, or political subdivisions or officers thereof, departments, agencies, or instrumentalities, or public or private corporation or officers thereof, organized or existing under the laws of this or any other state or country.

Permit means a written authorization issued by the Commissioner licensing one of the following: the construction, alteration, extension, or repair of a subsurface sewage disposal system, or the removal and disposal of accumulated wastes from subsurface sewage disposal systems, and including those engaged in such businesses.

Plans means any documents required by the Commissioner in the process of carrying out these Regulations. Plans may include, but not be limited to: applications, boundary outlines, plats, soil maps and topographic maps.

Plat means a map or other graphic representation drawn to scale, of a piece of land subdivided into lots, showing streets, waterlines, lot lines, etc.

Positive Drainage Plan means a plan by which all free water, both surface and subsurface, is removed from an area (lot, subdivision, etc.) by gravity, (even acquiring off-site easements where necessary).

RULEMAKING HEARINGS

Privy means a structure and/or excavation for the disposal of human excreta by non-water carriage methods.

Public Sewerage System means the conduits, sewers, and all devices and appurtenances by means of which sewage is collected, pumped, treated and disposed of; all of which are owned and operated by a municipality, utility district or other legally constituted agency of government.

Recirculating Gravel Filter (RGF) means a type of gravel filter wastewater treatment system which utilizes an effluent recycle system where a portion of the filtered effluent is mixed with septic tank effluent in a recirculation/dilution tank and redistributed to the filter.

Relief Line means a closed pipe laid on an undisturbed section of ground that conveys septic tank effluent from one trench to a subsequent trench on a lower elevation.

Restriction means a limitation on the use of properties where subsurface sewage disposal systems are proposed.

Restrictive Covenant means that document which restricts the use of property by its owner and specifies the obligations and responsibility of the owner regarding the property.

Rill means a small shallow (one foot or less in depth) ephemeral channel that carries water only during and for a few minutes after rainfall. Rills can be obliterated with conventional farm tillage implements.

Septage means a combination of organic sludge, liquid and scum which accumulates in septic tanks.

Septic Tank means a watertight receptacle which receives the discharge of sewage and is designed and so constructed so as to permit settling of solids from the liquid, digestion of organic matter by detention, retention of the floating solids, and discharge of the liquid portion.

Septic Tank Effluent means partially treated sewage which is discharged from a septic tank.

Septic Tank Pumping Contractor means any person engaged in the business of removing or disposing of the sludge and liquid contents of septic tanks or holding tanks.

Sewage means human excreta, all water carried wastes, and household wastes from residences, buildings, or commercial and industrial establishments.

Sink means a closed depression in an area of karst topography, that is formed either by the solution of the surficial limestone or by the collapse of underlying caves. Its form varies from basin-like to funnel shaped and its size varies from only a few feet across to several hundred feet across. The bottom of a sink most commonly consists of soil formed of materials which rolled or washed from the surrounding area and has slopes, which are generally, nearly level to undulating.

Slope or Grade means the rate of fall or rise of a pipeline or of the ground surface in reference to the horizontal plane.

Soil Absorption Rate means the rate, in minutes per inch, that clean water is absorbed by or drains through a soil during least favorable climatic conditions when soils are at or near field capacity. Estimated absorption rates are established in Appendix 1 for soil series and phases of soil series that have been recognized in Tennessee. For soil series and phases that have been recognized but not listed in Appendix 1 the Department shall establish the rate. Estimated soil absorption rates for variants of soil series and miscellaneous land

RULEMAKING HEARINGS

types may be established by an approved soil consultant; however, those rates may be established by the Department.

Soil Evaluation means the systematic examination of soils in the field and/or in laboratories, their description and classification, the mapping of kinds of soils or miscellaneous areas showing the distribution of soils in relation to the physical, cultural and special features of the earth's surface and the interpretation of the soils and site characteristics for their suitability for subsurface sewage disposal or to determine if the areas are eligible for percolation tests. The mapping is either general, high intensity or extra high intensity.

Soil Incorporation means the disking or plowing of the soil at a domestic septage disposal site, within six (6) hours of land application of domestic septage, so that no domestic septage is present on the surface of the soil.

Soil Injection means the injection of domestic septage below the surface of the soil.

Soil Map means a map showing the size, shape and distribution of the various kinds of soil in relation to other physical and cultural features on the earth's surface.

- (a) There are three (3) kinds of soil maps. They are general, high intensity and extra high intensity. They are defined as follows:
- (b) General – A general is a second order survey as defined in the Soil Survey Manual. United States Department of Agriculture, October 1993. These surveys are made for intensive land use that require detailed information. Map units shall be named at a categorical level above the soil series. Miscellaneous land types or interpretative groupings of soils such as those in which percolation tests are allowed for subsurface sewage disposal site evaluation shall be delineated. Map scale shall be one (1) inch equals one hundred (100) feet. Minimum size map unit delineations shall be twenty-five hundred (2500) square feet. The mapping legend shall be provided by the Department.
- (c) High Intensity – A first order survey as defined in the Soil Survey Manual, United States Department of Agriculture, October 1993. These surveys are made for very intensive land use that require very detailed soils information that require very precise knowledge of soils and their variability such as individual building sites. Field procedures require observation of soil boundaries throughout their length. Map units are mostly soil series, phases of soil series with some complexes and miscellaneous land areas. Some map units named at categorical level above the series are allowed. Map scale shall be one (1) inch equals one hundred (100) feet. Minimum size delineation shall be six hundred twenty-five (625) square feet.
- (d) Extra High Intensity – A map that is the same as a high intensity soil map except the scale may be one (1) inch equals one hundred (100) feet or one (1) inch equals fifty (50) feet. The minimum size delineation shall be one hundred (100) square feet. These maps have more cartographic detail than high intensity maps.

Soil Map Unit means an abstract model of a soil taxonomic unit or miscellaneous land type that has a set of distinguishing soil characteristics that set it apart from all other soil map units.

Soil Map Unit Delineation means an area on a soil map that represents a kind of soil or miscellaneous land type that occupies an area on the earth's surface. There may be several map unit delineations of one soil map unit.

RULEMAKING HEARINGS

Soil Series means a group of very similar soils that have one or more soil characteristics that distinguishes that soil from all other soil series. As used in these Regulations, a soil series is one that has been recognized by the Natural Resource Conservation Service in Tennessee.

Soil Taxadjunct means soil that has one or more distinguishing soil characteristics that prevents that soil from being classified in any soil series that has been recognized in Tennessee by the National Cooperative Soil Survey. A taxadjunct to a soil series does not differ enough to require different use and management or to expect different behavior from the named soil to which it is adjunct.

Soil Variant means a soil that has one or more distinguishing soil characteristics and soil properties that prevent that soil from being classified in any soil series that has been recognized by the National Cooperative Soil Survey in Tennessee. A soil variant requires use and management significantly different from the soil from which the variant is named. Also, behavior different from the soil series for which the variant is named can be expected.

Spring means a point where water naturally issues from the ground surface.

Storage Facility means a receptacle, which is designed to receive and retain septage prior to disposal, when the disposal site is not accessible.

Subdivision means any tract or parcel of land divided into two (2) or more lots, sites or other division for the purpose of immediate or future building of dwellings, buildings or other mobile or permanent structures where subsurface sewage disposal systems are to be used. Subdivision does not include a division of any tract or parcel of land into two (2) or more tracts or parcels when such parts are five (5) acres or larger in size.

Subsurface Sewage Disposal System means a system, other than a public or community system, which receives sewage. Included within the scope of this definition are: septic tank absorption systems, privies, chemical toilets, and other similar systems. However, a subsurface sewage disposal system does not include a sewerage system regulated under T.C.A. Sections 68-221-101 et. seq. and 68-3-101 et. seq.

Swelling means a condition caused by the intrusion of water into the individual clay particles.

Topographic Map means a map showing existing physical features, with contour lines at sufficient intervals to permit determination of proposed grades and drainage.

Vicinity Map means a map, which indicates the region near or about a place and the proximity to prominent and established landmarks.

Water Table means that level below which the soil or rock is saturated with water.

Authority: T.C.A. §§68-221-403, 4-5 *et seq.*

1200-1-6-.02 SUBDIVISIONS.

- (1) Approval by Other Agencies - No proposed subdivision shall be approved by the State Planning Office, a local or regional planning commission or other agency authorized to approve subdivisions until the plans for such subdivisions have been approved by the Commissioner.

RULEMAKING HEARINGS

- (2) Lot Size - Lots shall be large enough to construct the original subsurface sewage disposal system and to provide an area for duplication of that system. The area(s) for both original and duplicate systems shall meet the provisions of these Rules.
- (3) Evaluation and Lot Design - Either a High-Intensity or a General Soil Evaluation shall be conducted as described below.
 - (a) Soils Evaluation
 1. Mapping Procedures
 - (i) A high-intensity soil evaluation shall be made of the entire subdivision, the entire lot or a minimum of 20,000 square feet per lot. Each soil delineation shall be drawn and plotted using a scale of 1 inch to 100 feet. The soil mapping shall be done by a soil consultant approved by the department pursuant to the requirements of 1200-1-6-.17. Two (2) copies of such map shall be submitted to the Commissioner.
 - (ii) A general soil evaluation map shall be made of the entire subdivision using a standard mapping legend provided by the department and each soil delineation shall be drawn and plotted using a scale of one (1) inch to one hundred (100) feet. The soil mapping shall be done by a soil consultant approved by the department pursuant to the requirements of Rule 1200-1-6-.17. Two (2) copies of such map shall be submitted to the Commissioner. Soil delineations based on slopes, soil depth to rock and water problems shall be identified on the map. Each delineation appearing on the plat map through soil evaluation shall be interpreted by the soil consultants in terms of eligibility for percolation tests.
 2. When the services of a soil consultant are provided by the department, three (3) copies of a plat of the site drawn to a scale of one (1) inch equals one hundred (100) feet shall be submitted to the Commissioner. The site shall be either grid staked or lots staked as follows:
 - (i) A one hundred (100) feet master-grid system with surveyed control stakes numbered at not more than five hundred (500) feet intervals and the location of the same on the plat. The ratio of precision of the unadjusted survey shall be a minimum of 1:1000. The plat shall show the seal and signature of the surveyor and show a bar scale. Intermediate grid stakes with numbers at not more than one hundred (100) feet intervals shall be numbered and shown on the plat. The intermediate stakes may be set by rough chaining or other methods to a lesser degree of accuracy, however, said intermediate stakes shall be within two (2) feet of the distance shown. The Commissioner may require the removal of vegetative growth such as weeds, vines and briars to permit access to all parts of the property. In wooded areas cut/flagged lines shall be maintained until the property is evaluated.

RULEMAKING HEARINGS

- (ii) Staked lots must have a numbered surveyed stake at each corner. The ratio of precision of the unadjusted survey shall be a minimum of 1:1000. The plat shall show the seal and signature of the surveyor and show a bar scale. Intermediate ground control stakes shall be numbered and set in areas where lot corners are not visible from any point on the lot. The intermediate stakes must be set no more than two hundred (200) feet apart, and said intermediate stakes may be set by rough chaining or other methods to a lesser degree of accuracy, however, said stakes shall be within two (2) feet of the distance shown on the plat. The Commissioner may require the removal of vegetative growth such as weeds, vines, and briars to permit access to all parts of the property. In wooded areas cut/flagged lines shall be maintained until property is mapped.
 - 3. When the service of a private soil consultant is utilized, then the requirements in 1200- 1-6-.02(3)(a)2.(i) or (ii) shall apply.
- (b) Percolation Test
- 1. Under authority of T.C.A. Section 68-221-403(c), after a general or high intensity soil evaluation has been conducted by an approved soil consultant and the soils are found to have the following characteristics, then a percolation test may be conducted pursuant to Rule 1200-1-6-.04.
 - (i) There shall be a minimum depth of twenty-four (24) inches of undisturbed soil.
 - (ii) Slopes of more than thirty (30) percent do not qualify for percolation tests unless provisions of Rule 1200-1-6-.03(4)(d) are met.
 - (iii) No water problem shall exist. A water problem shall be considered to exist if any of the conditions are present as listed in the Soils Handbook.
 - 2. Where a percolation test is required to determine the percolation rate for a conventional system, the percolation holes used to determine this rate must be located at the intersection of lines in a grid pattern with maximum perpendicular distances of fifty (50) feet between the lines of the grid. Each hole shall be considered reasonably representative of a square area of two thousand five hundred (2,500) square feet which includes that hole in the approximate center of the square; or

Where a percolation test is required to determine the percolation rate for an alternative system, the percolation holes used to determine this rate must be located at the intersection of lines in a grid pattern with maximum perpendicular distances of twenty-five (25) feet between the lines of the grid. Each hole shall be considered reasonably representative of a square area of six hundred twenty-five (625) square feet, which includes that hole in the approximate center of the square.

RULEMAKING HEARINGS

Where percolation tests are used to determine the rate at which water moves through the soil, the minimum lot size shall be twenty thousand (20,000) square feet where a public water supply is used or a minimum of twenty-five thousand (25,000) square feet where a private water supply is used. The department shall be notified at least three (3) days prior to the day that the percolation test will be conducted. Percolation test procedures may be monitored when deemed necessary.

- (i) Two (2) copies of the subdivision plat at a scale of one (1) inch equals one hundred (100) feet shall be submitted to the Commissioner. Such plat shall show percolation test holes identified by number and plotted to scale, subdivision boundaries and other pertinent topographic features. All lot and grid lines shall be drawn with appropriate numbers shown on the plat corresponding with survey stakes on the ground.
- (ii) Tabulated results of percolation test holes shall be reported on a form provided by the department.
- (iii) The actual average percolation rate shall be determined by averaging only the test results from the area actually to be covered by the permit, which includes both initial and duplicate area. Areas in which percolation test results were unfavorable shall be excluded. The average percolation rate shall be calculated on a weighted basis.
- (iv) Percolation test results shall not be conclusive evidence as to the suitability of an area. Such tests shall be considered and analyzed as one of the many criteria in determining site suitability.

3. All percolation test locations shall adhere to the requirements of Rule 1200-1-6-.10(1).

(4) Construction Design

- (a) Each lot shall be accurately surveyed and lot boundaries designated by survey stakes with lot numbers shown on said stakes.
- (b) Three (3) copies of a subdivision plat at a scale of one (1) inch equals one hundred (100) feet shall be submitted to the Commissioner, which shall indicate:
 - 1. Lot dimensions with all lots numbered.
 - 2. Easements for any purpose.
 - 3. Surface and underground drainage designed so as not to interfere with subsurface sewage disposal systems.
 - 4. Positive drainage plan, where needed. A positive drainage outlet must be available for each lot before the final plat is signed. If construction of a positive outlet is necessary, all construction shall be done before final plat approval is given. Off property easements may be necessary.

RULEMAKING HEARINGS

5. Seal and signature of registered surveyor. (In order to survey and plat subdivisions an engineer, by law, must be a registered surveyor).
 6. Precision of the unadjusted survey. A minimum ratio of precision of the unadjusted survey of 1:7,500 is required.
 7. Vicinity map.
 8. North arrow indicating magnetic north or otherwise and indicate the scale of the plat.
 9. All final plats shall have distances on all lines and shall indicate the identity of all corners such as steel post, concrete or iron pin.
- (c) The submittals required under Rules 1200-1-6-.02(3) and 1200-1-6-.02(4) may be combined into one (1) submittal to the Commissioner.
- (d) After review of the site and information submitted, the Commissioner shall:
1. Approve in writing the subdivision as proposed, or
 2. Recommend in writing the corrections needed to receive approval, or
 3. Indicate in writing that the proposed subdivision or areas therein are not suitable with reasons therefore.
- (e) Where revisions are made to the construction design, revised plats shall be submitted to the Commissioner.
- (5) Additional Data
- Whenever the data required in these rules are insufficient to determine suitability of an individual lot or subdivision, additional data may be required by the Commissioner.
- (6) Final Approval
- (a) Two (2) copies of the final plat shall be submitted to the Commissioner with permanent lot lines drawn and the information required in Rule 1200-1-6-.02(3)(a) or 1200-1-6-.02(3)(b) and Rule 1200-1-6-.02(4). Additional plats for recording purposes without soil delineation, contour lines and percolation test hole locations may be submitted for approval.
 - (b) The maximum wastewater flow or maximum number of bedrooms for each lot shall be shown on the plat.
 - (c) Any subdivision plat may be subject to restrictions as determined by the Commissioner and such restrictions shall be recorded on or appended to the plat. This may include designation of primary and duplicate areas or soil area to be reserved for subsurface sewage disposal systems.

RULEMAKING HEARINGS

- (d) The Commissioner may approve a plat by attaching an appropriate signature after all provisions of these Rules are met.
 - (e) Before any changes or restrictions can be made or removed, a revised plat must be submitted to the Commissioner prior to approval. If the approved plat has been recorded at the county register of deeds office, any modifications will require rescission of the existing approved plat.
- (7) Individually owned lots in unapproved subdivisions shall meet the requirements of this rule with the exception that only one copy of each plat shall be submitted to the Commissioner, with the plat representing only the individual lot. Where a plat of the unapproved subdivision has been recorded, this rule shall only apply to those subdivisions recorded after June 30, 1995.

Authority: T.C.A. §§68-221-403, 4-5 et seq.

1200-1-6-.03 ADDITIONAL SITE REQUIREMENTS AND LIMITATIONS FOR SUBDIVISION APPROVAL AND INDIVIDUAL LOTS AND ISSUANCE OF CONSTRUCTION PERMIT.

- (1) Suitability of Site - Prior to the design of subsurface sewage disposal systems, the suitability of the site must be demonstrated through acceptable soil absorption rates, acceptable soil conditions, freedom from groundwater interference or slowly permeable strata below the level of the disposal field, and other topographic characteristics. For lots which are not part of a subdivision as defined herein, the Commissioner may determine site suitability, acceptable soil absorptions rates, acceptable soil conditions, freedom from groundwater interference or impervious strata below the level of the disposal field, and other topographic characteristics. For lots which are not part of a subdivision as defined herein, where the services of a soil consultant are utilized, then the requirements established in Rule 1200-1-6-.02(3)(a) of these Regulations may apply as deemed necessary by the department either on an area basis or site specific basis.
- (2) Watertable - The water table shall be at least four (4) feet below the bottom of the disposal field, except that a lesser depth may be permitted where soil conditions provide adequate protection for groundwater.
 - (a) Borings for determination of perched groundwater and the water table may be required by the Commissioner. In such cases, borings shall be made to a minimum depth of six (6) feet or as site conditions so warrant. Sufficient time shall be provided for stabilization of groundwater before water table elevations are recorded. In sandy soil this may require as little as thirty (30) minutes, while clay soil may require several hours or overnight. Borings shall be located by number on the plat map. Borings shall be conducted during the wettest part of the year and at a time approved by the Commissioner.
- (3) Rock - At sites where surface rock or subsurface rock formations exist to such degree as to affect operational effectiveness of subsurface sewage disposal systems, a sufficient number of borings to a minimum depth of six (6) feet may be required by the Commissioner to determine whether subsurface sewage disposal systems can be expected to give satisfactory service. Such borings shall be located by number on the plat and the results recorded.

RULEMAKING HEARINGS

- (a) Rock formations shall be at a depth greater than four (4) feet below the bottom of the disposal field trenches, provided a lesser depth may be permitted where soil conditions so warrant.
 - (b) Rock may be removed in the septic tank excavation if a smooth, firm, level bedding is provided.
- (4) Other Site Considerations:
- (a) Areas consisting of fill shall be excluded from the area considered for installation of the disposal fields unless soil conditions provide for adequate filtration and will prevent outcropping of sewage effluent.
 - (b) Gullies, ravines, dry stream beds, natural drainage ways, sinkholes, wells, springs, cisterns, streams, areas subject to flooding which have no surface drainage outlet and caves shall be excluded from consideration as usable areas for disposal systems.
 - (c) Sinks shall be considered unsuitable for subsurface sewage disposal unless the following requirements are met:
 - 1. Depth to rock formations must be a minimum of four (4) feet from the surface of the ground, and trench depth shall not exceed thirty (30) inches.
 - 2. Slopes must be thirty (30) percent or less.
 - 3. The area must not be subject to flooding.
 - 4. All other site suitability criteria must be met.
 - (d) Maximum slope permitted for the area to be used for the disposal field shall be determined by the consideration of lateral flow of effluent to the surface of the slope. Slopes of more than thirty (30) percent shall be considered unsuitable unless soil conditions will prevent lateral movement of sewage effluent to the ground surface. Slopes exceeding fifty (50) percent shall be considered unsuitable.
 - (e) Lot Grading - The area to be used for the disposal field shall not be disturbed when grading the lot. However, where this is unavoidable, a re-evaluation shall be made after grading has been completed. After the suitability of any area to be used for subsurface sewage disposal has been evaluated and approved for construction, no change shall be made to this area unless the Commissioner is notified and a re-evaluation of the area's suitability is made prior to the initiation of construction.
 - (f) When soils evaluations indicate the soil absorption rate to be less than ten (10) minutes per inch, a conventional subsurface sewage disposal system shall not be used.
- (5) Soil Improvements
- (a) Site Requirements

RULEMAKING HEARINGS

1. Sites where soil improvement is necessary to change soil absorption rates to the acceptable range shall be considered unsuitable for subsurface sewage disposal until the improvement is adequately noted on the recorded final plat and in addition, noted on the permit at the time of issuance.
2. Sites where soil protection practices are necessary to maintain soil absorption rates within the acceptable range shall be considered unsuitable for subsurface sewage disposal until the protection practice is adequately noted on the recorded final plat and in addition, noted on the permit at the time of issuance.

(b) Design

1. The improvement and/or protection practices shall be of such location, configuration and construction to adequately collect, remove and discharge by gravity all interfering surface and subsurface water and not to collect sewage or any effluent from a subsurface sewage disposal system.
2. The minimum trench width of the soil improvement and/or protection practice shall be twelve (12) inches.

(c) Material Specifications

1. The gravel in the improvement and/or protection practices must be of sufficient amount, size and quality to allow storage and free movement of the collected water.
2. If an impermeable barrier is necessary for proper performance of the improvement and/or protection practice, the barrier must be of sufficient strength and durability to withstand the conditions under which it must perform.
3. The collection pipe must have a minimum diameter of four (4) inches, or equivalent, and must be designed to collect groundwater. It must be constructed to withstand the conditions and weights under which it must perform.

Authority: T.C.A. §§68-221-403, 4-5 et seq.

1200-1-6-.04 PERCOLATION TEST PROCEDURES.

- (1) Type of Test Holes - The holes shall be dug or bored, with horizontal dimensions from six (6) to twelve (12) inches and vertical sides to the depth as appropriate for the type of system to be installed and the house that is to be constructed.
- (2) Preparation of Test Holes - Carefully scratch the bottom and sides of the holes with a knife blade or sharp pointed instrument in order to remove any smeared soil surfaces, and to provide a natural soil interface into which water may percolate. Remove all loose material from the holes. Add two (2) inches of coarse sand or fine gravel to protect the bottom from scouring and sediment.

RULEMAKING HEARINGS

- (3) Conducting the Test - Carefully fill the holes with clear water to a minimum depth of twelve (12) inches over the gravel. No additives shall be used at any time during the percolation test procedures. In most soils, it is necessary to refill the holes by supplying a surplus reservoir of water, possibly by means of an automatic siphon, to keep water in the holes at least four (4) hours and preferably overnight. The measurement period of the test shall begin twenty-four (24) to thirty (30) hours after initial filling.
- (4) Percolation Rate Measurement - Percolation rate measurement shall be made on the day following the procedure described under item (3) and calculations of area required for disposal fields shall be based on Appendix II.
- (5) If greater than six (6) inches of water remains in the test holes after the overnight presoaking period, adjust the depth to approximately six (6) inches over the gravel. From a fixed reference point, measure the drop in water level over a thirty (30) minute period. This drop is used to calculate the percolation rate.
- (6) If six (6) inches, or less, of water remains in the holes after the overnight presoaking period, add clear water to bring the depth of water in the holes to approximately six (6) inches over the gravel. From a fixed reference point measure the drop in the water level at approximately thirty (30) minute intervals for four (4) hours, refilling to approximately six (6) inches over the gravel after each reading. The drop that occurs during the final thirty (30) minute period is used to calculate the percolation rate. The drop that occurs during prior periods provides information for possible modification of the procedure to suit local circumstances.
- (7) Tests shall be conducted by an engineer or surveyor licensed in the State of Tennessee. An approved soil consultant or a registered professional environmentalist registered in the State of Tennessee may conduct percolation tests if they are not employed by a State, Regional, District, County or Municipal Department of Environment and Conservation.

Authority: T.C.A. §§68-221-403, 4-5 et seq.

1200-1-6-.05 CONSTRUCTION PERMIT.

- (1) No property owner or installer of a subsurface sewage disposal system shall construct, alter, extend, or repair subsurface sewage disposal systems within the State of Tennessee unless he holds a valid construction permit issued by the Commissioner.
- (2) The Commissioner shall refuse to grant a permit for the construction of a subsurface sewage disposal system where there is an accessible public sewerage system. The recipient of a permit for construction of a subsurface sewage disposal system shall be the responsible person(s) for adhering to the construction requirements of these Regulations.
- (3) These rules also apply in correcting existing failures; however, the Commissioner may allow repairs if the site does not meet the soil suitability; disposal field length and reserve area requirements.
- (4) The construction permit shall have an expiration date effective three (3) years from the date of issuance. All construction permits issued prior to February 4, 1990 shall expire on June 30, 1996.

RULEMAKING HEARINGS

(5) Electrical Inspector Notification

- (a) Any person who intends to construct or locate a house or establishment, mobile or permanent, after June 30, 1994, shall furnish evidence to the official electrical inspector that:
 - 1. An application for a subsurface sewage disposal system construction permit has been made (on a form provided by the Division of Ground Water Protection), or;
 - 2. The house or establishment is served by a public sewerage system.
- (b) Provided however, this shall not apply to farm buildings or other buildings which are not connected to a public sewerage system or a subsurface sewage disposal system.
- (c) Where an existing subsurface sewage disposal system is to be utilized, a statement shall be provided by the Division of Ground Water Protection (upon notification by the landowner or their agent) that will serve as evidence that the requirements of Tennessee Code Annotated, Section 68-221-414(a) have been met.
- (d) Where there is an established countywide building permit program, as determined by the Commissioner, or where power is being restored, the provisions of this rule shall not apply.

Authority: T.C.A. §§68-221-403(a)(2) and (3) and 68-221-414(f)(1).

1200-1-6-.06 DESIGN OF THE CONVENTIONAL DISPOSAL FIELD.

- (1) The size of the conventional subsurface sewage disposal system shall be determined by the following:
 - (a) The suitability of the site shall be determined by a high or extra high intensity soil map completed by an approved soil consultant and other criteria established by these Regulations. The soil absorption rates that range from ten (10) through seventy-five (75) minutes per inch are acceptable. Soil absorption rates for soil series and phases of soil series that are established in Appendix I shall apply. The absorption rates for soil series and phases that have been recognized by the Natural Resource Conservation Service in Tennessee but not listed in Appendix I shall be established by the department. Rates for soil variants and miscellaneous land types may be established by an approved soil consultant but may require approval by the department.
 - (b) Where percolation tests are conducted the size of the subsurface sewage disposal system shall be determined by the rate found in Appendix II. The minimum square footage of trench bottom installed per bedroom shall be three hundred and seventy (370).

RULEMAKING HEARINGS

- (c) On individual lots where the Commissioner determines site suitability, an estimated soil absorption rate up to and including seventy-five (75) minutes per inch may be established. The size of the conventional subsurface sewage disposal system shall be determined by the rate found in Appendix II.
 - (d) Soils with absorption rates greater than seventy-five (75) minutes per inch as determined by a soil evaluation shall be considered unsuitable for conventional subsurface sewage disposal. Soils with percolation rates less than one hundred and six (106) minutes per inch may be used for conventional systems under authority of T.C.A. §§68-221-403(c)(1).
- (2) Where conventional subsurface sewage disposal systems are installed, sufficient additional area must be available for the expansion of the disposal field in an amount large enough to install the secondary disposal field as required by these Regulations.
- (3) Design of the disposal field shall be of the recirculating (level lot) or serial distribution type or a modification of either, depending on the characteristics of the site.
- (a) Recirculating Design - Where the elevation difference in the area utilized for the absorption field does not exceed twelve (12) inches, a recirculating system is preferred. A recirculating design provides equal distribution of the effluent throughout the entire system by connecting successive trenches on both ends and by maintaining the grade in the bottom of these trenches from level to no more than four (4) inches. In this manner, the entire absorption area within the sewage system is utilized concurrently.
 - (b) Serial Distribution - This design is preferred where the elevation difference of the ground surface over the absorption field area exceeds twelve (12) inches. In serial distribution, each adjacent trench is connected to the next by a closed pipe laid on an undisturbed section of ground. The arrangement is such that all effluent is discharged to the first trench until it is filled. Excess liquid is then carried by means of a closed line (relief line) to the next trench. In this manner, each portion of the subsurface system is used in succession.
 - (c) Large Conventional Systems - Those exceeding two thousand two hundred and fifty (2,250) square feet of disposal field.
 - 1. When the disposal field exceeds two thousand two hundred and fifty (2,250) square feet of trench bottom in a single system, a properly designed dosing system shall be used for discharging septic tank effluent into the disposal field. The Commissioner shall require design plans by a licensed engineer. The Commissioner may also require:
 - (i) Prior to design approval, a licensed engineer must agree, in writing, to monitor the installation and construction of the system and upon completion, provide a final set of as built plans encompassing all components of the system and certification that the installation is in accordance with the design specifications.
 - (ii) Prior to design approval, it shall be the responsibility of the department to review the aforementioned design and notify the

RULEMAKING HEARINGS

engineer, in writing, of approval of the plans, denial of the plans or needed modifications to the plans.

2. When the design daily flow from a single source exceeds three thousand (3,000) gallons per day, siphons or pumps shall be used which shall discharge to separate disposal fields. Each system shall not exceed a design capacity of three thousand (3,000) gallons per day.
3. Discharges from dosing systems shall be designed to maximize the distribution of the effluent throughout the system.
4. Buffer zones shall be required at a frequency and size as determined by a detailed soil/site evaluation.
5. The daily wastewater flow from residences or other similar establishments shall be based upon one hundred and fifty (150) gallons per bedroom per day.

(4) Construction Procedure for Disposal Field

- (a) The pipe size from the septic tank to the disposal field or pump chamber shall not be less than three (3) inches in diameter (inside measurement) and shall be of equivalent strength of Schedule 40 PVC except where Rule 1200-1-6-.14 applies. The pipe from the septic tank to the disposal field shall be of sufficient length to rest on undisturbed earth.
- (b) Materials and equipment used in subsurface sewage disposal systems shall be those which have specifications outlined in these Regulations.
- (c) The disposal field trenches shall follow the ground surface contours so that variations in trench depth will be minimized.
- (d) A minimum of six (6) feet of undisturbed earth between adjacent trench walls shall be required.
- (e) Adjacent trenches in a serial distribution system shall be connected with a relief line in such a manner that each trench is completely filled with septic tank effluent to the full depth of the media before effluent flows to a succeeding trench.
- (f) In constructing relief lines, care must be exercised to insure that an undisturbed block of earth remains between trenches. The trench for the relief pipe, where it connects with the preceding absorption trench, shall be dug no deeper than the top of the media. The relief line shall rest on undisturbed earth and backfill must be carefully tamped. This section pertains primarily to a serial distribution system. Pipe for relief lines shall have no perforations and shall have a minimum inside diameter of three (3) inches and shall be Schedule 40 pipe or equivalent. All couplings and/or connections must be accomplished with materials/fittings manufactured specifically for Schedule 40PVC or equivalent to the point of connection with the pipe in the disposal field and shall provide a secure connection. The lengths of pipe used for relief lines shall not be considered part of the required absorption area.

RULEMAKING HEARINGS

- (g) The influent and effluent relief lines in each individual trench shall be as far from each other as practical in order to prevent short circuiting.
- (h) Invert of the overflow pipe in the first relief line shall be at least four (4) inches lower than the invert of the septic tank outlet.
- (i) Trenches shall not be excavated when the soil is wet enough to smear or compact easily.
- (j) Media for the disposal fields shall consist of crushed rock, gravel or other suitable material as approved by the department, and shall be size number 2, 3, 4, or 24 coarse aggregate, as defined by ASTM D-448-86. The material shall be free from dust, sand, clay or excessive fines. At least ninety (90) percent of the material must pass a two and one-half (2 1/2) inch screen and not more than five (5) percent may pass a one-half (1/2) inch screen.
- (k) Media for the disposal fields shall extend from at least two (2) inches above the top of the perforated field line pipe to at least six (6) inches below the bottom of the perforated field line pipe (a minimum of twelve (12) inches total).
- (l) The top of the disposal field media shall be below the invert of the tank outlet.
- (m) The media for the disposal fields shall be covered with untreated building paper, a layer of straw at least two (2) inches thick or other material determined to be equivalent by the Commissioner.
- (n) Soil material excavated from trenches should be used in backfilling and should be left mounded over the trenches until initial settling has taken place.
- (o) There shall be a minimum of twelve (12) inches of ground cover over the disposal field media and the maximum shall be thirty-six (36) inches of fill, except for systems designed pursuant to T.C.A. §§68-221-403(i).
- (p) The bottom of the trenches and the distribution lines shall have a grade from level to no greater than four (4) inches.
- (q) All pipes (tight lines) under paved areas or under driveways shall be Schedule 40 PVC or equivalent and have a minimum inside diameter of three (3) inches. The lengths of pipe used for relief lines and tight lines shall not be considered part of the required absorption area.
- (r) The pipe used in the disposal field trenches shall have a minimum diameter of four (4) inches, be perforated with one-half (1/2) inch holes and conform to or exceed the standards of ASTM F-405-82A.
- (s) The area of the disposal field shall not be used for vehicular traffic or vehicular parking. Dozers, trucks, and other heavy vehicles shall not be allowed to run over the septic tank, field lines or other parts of the system.
- (t) The maximum length of a single line should not exceed one hundred (100) feet unless conditions require a longer line.

RULEMAKING HEARINGS

- (u) The maximum depth of a trench shall be forty-eight (48) inches. The minimum depth shall be twenty-four (24) inches, except for systems designed pursuant to T.C.A. §§68-221-403(i).
 - (v) The area of the disposal field shall not be used for any underground utilities.
 - (w) A septic tank must not be bypassed by direct line (laundry, grease, etc.) to field line.
 - (x) Down-spouts shall not be connected to the subsurface sewage disposal system. Down-spouts or other surface water shall be diverted away from the subsurface sewage disposal system.
 - (y) Water lines shall not cross, pass through, or go under the subsurface sewage disposal field. Water lines may cross, but not be located in the same trench with, a tight line leading from a septic tank or dosing tank to a disposal field provided the water line is sleeved in a continuous twenty (20) feet section of Schedule 40 PVC pipe or equivalent (a minimum of ten (10) feet on either side of the tight line) and the water line is a minimum of one (1) foot vertically above the tight line.
- (5) No system shall be covered without the inspection and authorization of the Commissioner.

Authority: T.C.A. §§68-221-403, 4-5 et seq..

1200-1-6-.07 SEPTIC TANK CAPACITY.

- (1) For residences, the liquid capacity of the septic tank shall be based on the following:

<u>Number of Bedrooms</u>	<u>Capacity in Gallons</u>
2 or less	750
3	900
4 ^a	1000

^aFor each additional bedroom, add two hundred and fifty (250) gallons.

- (2) For facilities other than residences, the net volume or effective liquid capacity below the flowline of a septic tank for flows up to five hundred (500) gallons per day shall be at least seven hundred fifty (750) gallons. For flows between five hundred (500) and fifteen hundred (1500) gallons per day, the capacity of the tank shall be equal to at least one and one-half (1 1/2) days' liquid sewage flow. With flows greater than fifteen hundred (1500) gallons per day the minimum effective tank liquid capacity shall equal one thousand one hundred and twenty-five (1125) gallons plus seventy-five (75) percent of the daily sewage flow; or $V=1125+0.75Q$ where V is the volume of the tank in gallons and Q is the daily sewage flow in gallons. Additional tank volume may be necessary where unusual waste water characteristics are expected from a facility. Expected normal sewage flows may be determined from a

RULEMAKING HEARINGS

list as provided by the department or actual known water usage data for any facility to be served may be used if available.

Authority: T.C.A. §§53-2044.

1200-1-6-.08 DESIGN OF SEPTIC TANKS.

- (1) A septic tank shall be watertight, structurally sound, and not subject to excessive corrosion or decay. Septic tanks installed after January 1, 1991 shall be of two (2) compartment design. The inlet compartment of a two (2) compartment tank shall be between two-thirds ($\frac{2}{3}$) and three-fourths ($\frac{3}{4}$) of the total tank capacity.
- (2) Minimum standards of design and construction of precast reinforced concrete septic tanks:
 - (a) The liquid depth may range from thirty (30) to sixty (60) inches for septic tanks of less than three thousand (3000) gallons capacity and may not exceed seventy-eight (78) inches for septic tanks with a capacity of three thousand (3000) gallons or greater.
 - (b) All tanks shall be manufactured with a partition so that the tank contains two (2) compartments. The partition shall be located at a point not less than two-thirds ($\frac{2}{3}$) nor more than three-fourths ($\frac{3}{4}$) the length of the tank from the inlet end. The tank wall thickness must remain not less than two and one half ($2 \frac{1}{2}$) inches thick throughout the tank except for blockouts or the groove for a slide-in partition. The groove for the slide-in partition shall leave a concrete thickness of not less than two and one-fourth ($2 \frac{1}{4}$) inches in the tank walls. The partition shall be structurally sound and not subject to excessive corrosion or decay.
 - (c) There shall be three (3) blockouts in the inlet compartment, one (1) on the tank end and one (1) on each sidewall, and a blockout in the partition and the outlet end of the tank. The blockouts for these openings shall leave a concrete thickness of not less than one (1) inch in the tank wall. The blockouts shall be made for a minimum of four (4) inch pipe or a maximum of six (6) inch pipe. In lieu of the partition wall blockout, a four (4) to six (6) inch slot extending at least half way across the width of the tank may be used. The top of the slot shall be located no closer than twelve (12) inches to the liquid level and the bottom of the slot shall be no lower than four (4) inches below the midpoint of the liquid depth. A four (4) inch diameter, or equivalent, air passage opening in the partition shall be provided above the liquid level of the tank.
 - (d) The tees or baffles shall be a minimum diameter of either three (3) inch cast iron soil pipe T branch, three (3) inch cast iron sanitary T branch, three (3) inch cast-in-place baffle, or three (3) inch PVC T branch or equivalent in durability and performance as determined by the Central Office of the Division of Ground Water Protection.
 - (e) The inlet invert shall enter the tank at least one (1) inch, preferably three (3) inches, above the liquid level of the tank.

RULEMAKING HEARINGS

- (f) An inlet tee or baffle shall be provided to divert the incoming sewage downward and extend at least twelve (12) inches below the liquid level.
- (g) The partition tees or baffles and outlet tee or baffle shall extend eighteen (18) inches or one-third (1/3) the liquid depth, whichever is the lesser, below the liquid level of the tank. A tee or baffle shall be provided on the first compartment side of the partition at the same elevation as the outlet tee or baffle unless an intercompartmental connecting slot is utilized as described in (2)(c) of this rule.
- (h) Air space equal to at least twenty (20) percent of the liquid depth shall be provided between the top of the tank and the liquid level.
- (i) Adequate access openings above each tee or baffle must be provided in the tank top. Access shall be provided for cleaning or rodding out of the inlet pipe, and the interconnecting tees or baffles in the partition, for inserting the suction hose for tank pumping, and for entrance of a person if internal repairs are needed after pumping. If the knockouts on the inlet compartment sides of the tank are to be used access to these tees or baffles shall also be provided for cleaning and rodding of the inlet pipe. To accomplish this, it may be necessary to extend the tee so they will be located under an access port or a cleanout must be provided on the inlet line immediately outside the septic tank. A manhole opening shall be provided to each compartment with each having a minimum opening of eighteen (18) inches by eighteen (18) inches as the opening cuts the plane of the bottom side of the top of the tank. All circular shaped manholes shall have a minimum diameter of twenty (20) inches as the opening cuts the plane of the bottom side of the top of the tank. The manhole covers shall be beveled on all sides in such manner as to accommodate a uniform load of one hundred fifty (150) pounds per square foot without damage to the cover or the top of the tank. If the top of the tank is to be multislab construction, the slabs over the inlet of the tank, partition, and outlet of the tank must not weigh in excess of one hundred fifty (150) pounds each. Multislab construction must allow for a minimum access hole size of six (6) inches by six (6) inches to each compartment. Manhole covers, opening covers, or slabs shall have a handle of steel or other corrosion resistant material equivalent in strength to a No. 3 reinforcing rod (rebar).
- (j) The tank shall be properly vibrated and rodded prior to curing to eliminate honeycomb.
- (k) The top, bottom, ends, and sides of the tank must have a minimum thickness of two and one-half (2 1/2) inches except for blockouts or the slide in partition groove.
- (l) After curing, tanks manufactured in two (2) sections shall be joined and sealed at the joint by the manufacturer by using a mastic sealant and/or pliable sealant that is both waterproof and corrosion resistant.
- (m) Tank Labeling - Precast septic tanks shall be provided with a suitable legend, cast or etched in the wall at the outlet end and within six (6) inches of the top of the tank, identifying the manufacturer by name and address or registered trademark and indicating the liquid capacity of the tank in gallons.

RULEMAKING HEARINGS

- (3) Plans for prefabricated tanks, other than those for precast reinforced concrete tanks, shall be approved by the department, on an individual basis as determined by the information furnished by the designer which indicates the tank will provide equivalent effectiveness as those designed in accordance with the provisions of section 2 of this rule.
- (4) Septic tanks other than approved prefabricated tanks shall be constructed consistent with the provisions of paragraph (2) of this rule except as follows:
 - (a) Cast-in-place concrete septic tanks shall have a minimum wall thickness of six (6) inches.
 - (b) Cast-in-place septic tanks of one thousand (1000) gallons or smaller shall have a minimum top and bottom thickness of four (4) inches.
 - (c) Cast-in-place concrete septic tanks with a capacity of greater than one thousand (1000) gallons shall have a minimum top and bottom thickness of six (6) inches.

Authority: T.C.A. §§53-2044.

1200-1-6-.09 EFFLUENT TREATMENT DEVICES/SYSTEMS.

- (1) Septic Tank and/or Dosing Tank Filters, Conventional Sand Filters, and Recirculating Gravel Filters may be used to improve the quality of septic tank effluent in an approved subsurface sewage disposal system.

Authority: T.C.A. §§68-221-403(a)(2) and 4-5-201 et.seq.

1200-1-6-.10 LOCATION OF SEPTIC TANKS, DOSING CHAMBERS AND ABSORPTION FIELDS.

- (1) The location of septic tank, dosing chamber, and disposal field shall be selected in accordance with the following minimum distances in feet, bearing in mind that local conditions may require increased distances of separation.

	Septic tank and/or Dosing ____ Chamber _____	Disposal _____ Field
Water Supply	50	50
Dwellings	5	10
Property Lines	10	10
*Gullies, Ravines, Dry Stream Beds, Natural Drainageways, Sinkholes, Streams, and Cut Banks	15	25
Water Lines	10	10
House to Tank Connections	--	10
Septic Tank	--	5

*These distances may increase or decrease as soil conditions so warrant as determined by the Commissioner after a special investigation by an approved soil consultant.

RULEMAKING HEARINGS

Authority: T.C.A. §§68-221-403, 4-5 et seq.

1200-1-6-.11 DESIGN OF DOSING SYSTEMS.

(1) Dosing Chamber

- (a) The dosing chamber, access riser and riser cover shall be watertight, structurally sound and not subject to excessive corrosion or decay. The dosing chamber shall be of one (1) compartment design. They shall be of such construction and size as specified in Rule 1200-1-6-.08 Sections 2, 3 and 4, excluding those requirements strictly relating to two (2) compartments.
 - 1. The access riser shall have a minimum diameter of twenty-four (24) inches and extend to the finished grade or above. Rectangular or square risers may be allowed provided the size of the opening provides the equivalent access as a circular riser. An access riser with a minimum diameter of sixteen (16) inches may be used provided the threaded union on the pump outlet pipe is located within two (2) feet of the top of the access riser. The access riser shall be located near the outlet end of the tank, directly above the pump or siphon, supply line, switches and other fixtures.
- (b) The dosing chamber volume shall be a minimum of two (2) times daily wastewater flow except when an alternate pump equipped with an in-tank supply line and switch assembly is on-site and ready for use. If the alternate pump, in-tank supply line and switch assembly is on-site and ready for use, the minimum dosing chamber volume shall be a total of the volume of water below the static level plus the designed dosing volume plus one-half (1/2) the daily flow.

(2) Design of Pumps, Pipes, and Controls

- (a) The gallons per minute (gpm) flow in a dosing system shall be determined by the distribution network it doses. If the distribution network is of such design that the gpm flow is not confined to specific amounts, the minimum flow shall be ten (10) gpm.
- (b) Total dynamic head (TDH) shall be determined by adding the following:
 - 1. Elevation head is the difference in elevation between the bottom of the pump and the highest ground elevation at the disposal field. The minimum assigned elevation head shall be five (5) feet.
 - 2. Friction head shall be determined from Appendix III plus fittings loss.
 - 3. Pressure head is the amount of pressure desired at the distribution network and shall be a minimum of one (1) foot.
- (c) When pumping uphill, a check valve must be utilized if the volume of effluent which will flow back into the tank exceeds one-fourth (1/4) daily flow.

RULEMAKING HEARINGS

- (d) The dosing volume shall be between one-fourth (1/4) and one-half (1/2) daily flow, except in those situations where the minimum dose exceeds one-half (1/2) daily flow, then the calculated minimum dose shall be the dosing volume.
- (e) Pipe and Fittings
 - 1. All pipe materials shall be a minimum of Schedule 40 PVC.
 - 2. All fittings shall be pressure fittings.
 - 3. All connections shall be adequately cleaned with cleaning solvent and glued with PVC solvent cement.
 - 4. If used, the gate or globe valve(s) and check valve shall be either bronze or PVC.
 - 5. The supply line shall be designed and installed to drain after each use unless system design requires a check valve.
- (f) Pump, Float Controls, and Alarm System
 - 1. The pump shall be a good quality, effluent pump and be of sufficient size to meet or exceed the gallons flow requirement and the total dynamic head requirement set forth by the system.
 - 2. The pump float controls must be adjustable.
 - (i) The controls must be sealed against entry of effluent or gases.
 - 3. The alarm system.
 - (i) The high water alarm shall be required and consist of an audible and visible alarm located in a visible place and clearly marked "wastewater system alarm."
 - (ii) The alarm and alarm switches shall be placed on a separate electrical circuit from the pump power line.
 - (iii) The alarm float control shall be placed so as to be activated when the pump chamber water level rises above the "pump on" float control.
- (g) Pump and Controls
 - 1. The pump must be placed so that the intake is a minimum of eight (8) inches above the bottom of the pump chamber.
 - 2. As a means to remove the pump from the pump chamber, a material of sufficient strength and durability must be secured to the pump and access riser.

RULEMAKING HEARINGS

3. The pump control must be positioned so the "pump off" switch is slightly above the top of the pump and the "pump on" switch is at the desired dosing depth. The "pump off" switch for pumps specifically designed to operate with the pump motor casing exposed to air, may be located at a lower elevation provided an adequate depth of wastewater is maintained above the pump intake to insure that the pump intake will not draw in air.
 4. The pump outlet pipe must be connected to the supply manifold with a threaded union or similar device.
 5. When a disposal system requires a specific pressure head, a PVC or bronze, gate or globe valve shall be placed in the supply line.
 6. If the effluent is pumped downhill, a five-thirty seconds (5/32) inch siphon breaker hole must be drilled in the bottom of the supply line inside the pump tank, above the liquid level.
 7. All electrical installations shall be installed to meet the current wiring methods of the current edition of the National Electric Code (NEC) adopted by the State Fire Marshall's office.
- (3) Where elevation permits and a dosing siphon is used, it shall be designed in accordance with the minimum dose requirements in this rule and capable of meeting those requirements. It shall be durable, structurally sound and not subject to excessive corrosion or decay.

Authority: T.C.A. §§68-221-403, 4-5 et seq.

1200-1-6-.12 MAINTENANCE OF THE SUBSURFACE SEWAGE DISPOSAL SYSTEM.

- (1) It is the property owner's responsibility to maintain the system in a safe and sanitary manner.
- (2) Should the system malfunction, the Commissioner shall issue, in writing, a maximum thirty (30) day notice to the owner requiring repair, replacement or improvement of the system.

Authority: T.C.A. §§53-2044.

1200-1-6-.13 GREASE TRAPS.

- (1) Grease Traps in Commercial Buildings - Kitchen drain lines from institutions, hotels, restaurants, schools, lunchrooms, and other establishments from which flow a relatively high volume of grease may be discharged to a grease trap. Grease trap effluent shall also be treated in the septic tank before being discharged into the disposal field.
- (2) Grease traps shall be constructed to insure that both the inlet and outlet are properly submerged to trap grease, and that the distance between inlet and outlet is sufficient to allow separation of the grease so that grease solids will not escape through the outlet.

RULEMAKING HEARINGS

- (3) Grease traps shall be vented so they will not become airborne. A cover shall be provided and located so as to be conveniently accessible for servicing and cleaning. The cover shall be designed to prevent odor and exclude insects and vermin.
- (4) Garbage Grinder Waste - Waste from garbage grinders shall not pass through any grease trap before being discharged to a septic tank.
- (5) Sizing the Grease Trap - Proper sizing of the grease trap should be based on efficiency ratings and flow capacities, which are determined by the number and kinds of sinks or fixtures discharging into the trap.

Authority: T.C.A. §§68-221-403, 4-5 et seq.

1200-1-6-.14 ALTERNATIVE METHODS OF SUBSURFACE SEWAGE DISPOSAL.

- (1) Regarding alternative methods of subsurface sewage disposal, if a conflict occurs between this Rule and other Rules of these Regulations, the items of this Rule shall apply. However, the Commissioner may allow repairs if the site does not meet soil suitability and reserve area requirements. The wastewater flow for residences or other similar establishments served by alternative methods of subsurface sewage disposal shall be based upon one hundred fifty (150) gallons per bedroom per day.
- (2) Large Alternative Subsurface Methods of Sewage Disposal - Any alternative subsurface sewage disposal system that has a wastewater flow greater than six hundred (600) gallons per day, other than a large diameter gravelless pipe system, shall be considered a large alternative subsurface sewage disposal system. A large diameter gravelless pipe system that exceeds seven hundred fifty (750) linear feet of ten (10) inch pipe or eleven hundred twenty-five (1125) linear feet of eight (8) inch diameter pipe shall meet the minimum requirements established in Rule 1200-1-6-.06(3)(c).
 - (a) A site specific design for each large alternative subsurface sewage disposal system shall be submitted to the department for review.
 - (b) The design shall be stamped with the seal of a licensed engineer.
 - (c) Prior to design approval, a licensed engineer must agree, in writing, to monitor the installation and construction of the system and upon completion, provide a final set of as built plans encompassing all components of the system and certification that the installation is in accordance with the design specifications.
 - (d) It shall be the responsibility of the department to review the aforementioned design and notify the engineer, in writing, of approval of the plans, denial of the plans or needed modifications to the plans.
- (3) A Low Pressure Pipe (LPP) system is a subsurface sewage disposal system, which has three basic design principles different from conventional subsurface sewage disposal systems. They are: 1) uniform distribution of effluent, 2) dosing and resting cycles, and 3) shallow placement of trenches. When lots that are less than twenty thousand (20,000) square feet are proposed, the department shall determine the necessity, location and design of buffer zones. LPP systems shall not be used to dispose of wastewater wherein the average

RULEMAKING HEARINGS

concentration of grease exceeds one hundred fifty (150) milligrams per liter (mg/L) because of the clogging potential of the distribution network.

LPP systems designed to accommodate wastewater flows in excess of six hundred (600) gallons per day must be designed by a licensed engineer. The design shall be reviewed by the department applying Rule 1200-1-6-.14(2).

(a) Site and Soil Requirements

1. Prior to the design of the LPP system, the suitability of the site must be demonstrated through acceptable soil absorption rates, acceptable soil conditions and other topographic characteristics. The acceptable soil absorption rate range shall be from ten (10) minutes per inch through seventy-five (75) minutes per inch as determined by an extra high intensity soil map prepared by an approved soil consultant. If the soil absorption rate is determined to be greater than seventy-five (75) minutes per inch based upon the extra high intensity soil map, then percolation tests may be conducted. However, soils with absorption rates in excess of seventy-five (75) minutes per inch due to wetness that cannot be corrected by drainage shall not be eligible for percolation tests. Percolation rates from seventy-six (76) minutes per inch through one hundred twenty (120) minutes per inch are acceptable if no water problems exist.
2. A minimum soil depth of thirty (30) inches over any underlying restrictive horizon is required. However, a modified LPP system may utilize a maximum of six (6) inches of compatible fill, as determined by an approved soil consultant, to obtain the thirty (30) inch depth.
3. Slopes of more than thirty (30) percent shall be considered unsuitable.
4. An area of suitable soil must be available to install the initial system and maintain a suitable area of adequate size for 100% duplication.
5. The size of the LPP system shall be determined by the following:
 - (i) An extra high intensity soil map, provided by a soil consultant approved by the department, shall establish the soil absorption rate.
 - (ii) If the extra high intensity soil map determines that a percolation test is necessary to establish a rate, the percolation holes shall be located in a grid pattern with maximum perpendicular distances between holes of twenty-five (25) feet and the gridded portion shall encompass the entire area to be utilized for the system and duplicate area. Greater distances may be allowed as determined by the Commissioner. The percolation test procedure in Rule 1200-1-6-.04 of these R
 - (iii) Regulations shall apply.

RULEMAKING HEARINGS

- (iii) The daily wastewater flow divided by the loading rate (Table I) shall determine the amount of square footage (area) required for the initial system.
- (iv) Hydraulic overloading of the disposal field may occur when excessive amounts of effluent are distributed over a continuous common slope. Therefore, buffer zones are required if there is more than six (6) feet of elevation difference between the upper and lower laterals or if the distance between the upper and lower laterals exceeds fifty (50) feet. The buffer zone size and the use of soil improvement or soil protection practices are site specific and shall be determined by the Commissioner based on the recommendation of an approved soil consultant. The buffer zone shall not be included as part of the reserve area.

TABLE I. Maximum Loading Rate

Established Rate (mpi)	Loading Rate (gpd/ft ²)
10	.40
20	.40
30	.35
40	.30
45	.275
50	.25
60	.20
75	.15
90	.10
120	.05

(b) Layout of the LPP System

1. The required linear footage is determined by dividing the amount of required square footage of suitable soil area by five (5).
2. The location of the septic tank, dosing chamber, and the disposal field shall be in accordance with Rule 1200-1-6-.10 of these Regulations.
3. The lateral lines shall be placed on contour and lengths shall not exceed those specified in Figure 1.
4. The trench bottom of each lateral shall be at the same elevation throughout that lateral.

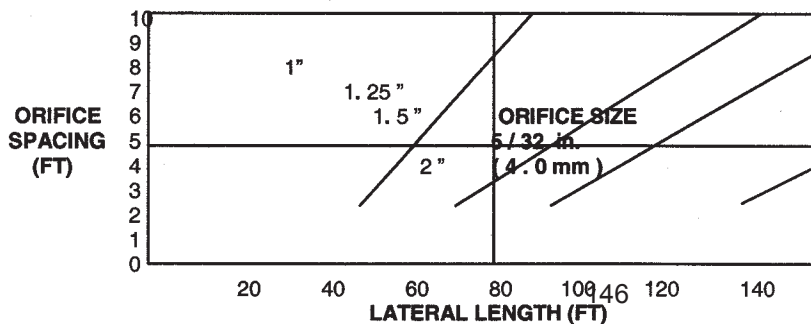

RULEMAKING HEARINGS

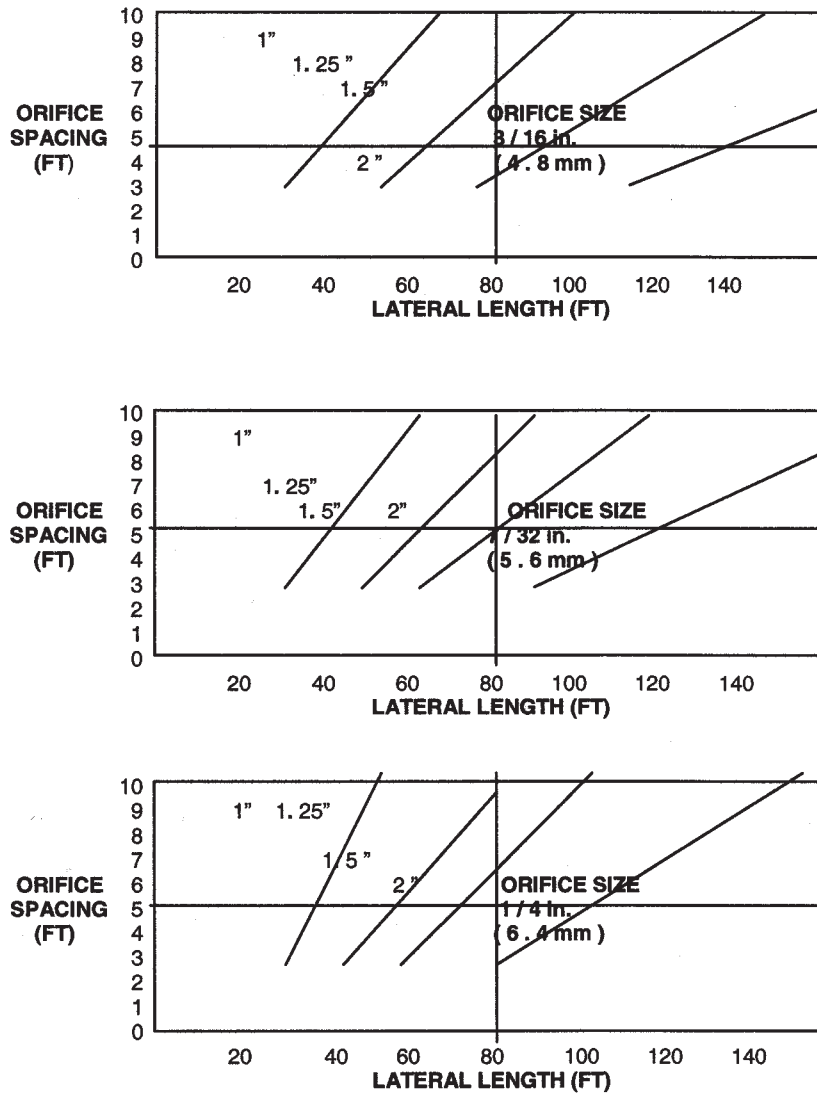

Figure 1. Maximum Length of Different Sized Laterals for Low Pressure Pipe Systems with Varying Orifice Sizes and Spacing (1 ft. = .305 m)

5. The distance between laterals (center to center) shall not be less than five (5) feet.
6. Trench width shall be a minimum of twelve (12) inches.
7. Trench depth shall range between eighteen (18) and twenty-two (22) inches.

RULEMAKING HEARINGS

8. A minimum of twelve (12) inches of soil material shall be present between the bottom of the trenches and the restrictive layer.

(c) Dosing and Distribution System Design

1. The dosing rate per linear foot of disposal trench shall be uniform over the entire system. This may be accomplished by varying the hole spacing, hole sizing, or placement of valves in the manifold or laterals to compensate for changes in ground elevation. Table II shall be used to calculate dosing rates.

TABLE II. Pressure Head vs GPM Flow Per Hole

Pressure Head ft.	psi.	Hole diameter (in.)		
		<u>5/32</u>	<u>3/16</u>	<u>7/32</u>
1	.43	.29	.42	.56
2	.87	.41	.59	.80
3	1.30	.50	.72	.98
4	1.73	.58	.83	1.13
5	2.16	.64	.94	1.26

2. The first and last holes in a lateral shall be thirty (30) inches from the ends of the lateral. Hole spacing shall not exceed seven and one-half (7.5) feet.
3. Hole sizes shall be within the range of five thirty-second (5/32) inches through seven thirty-second (7/32) inches.
4. Calculation of gallons per minute (gpm) flow and total dynamic head.
 - (i) The gallons per minute flow amount which the pump must provide shall be determined by adding the gallons per minute flows per hole over the system dosed by that pump.
 - (ii) The total dynamic head (TDH) shall be determined by adding the following:
 - (I) Elevation head is the difference in elevation between the bottom of the pump and the highest ground elevation at the disposal field. The minimum assigned elevation head shall be five (5) feet.
 - (II) Friction head shall be determined from Appendix III plus fittings loss.
 - (III) A pressure head average of three (3) feet shall be used for TDH calculations. The range shall be one (1) through five (5) feet.
5. When pumping uphill, a check valve must be utilized if the volume of the supply line, manifold, and the volume of the laterals that drain back into the pump tank exceeds one-fourth (1/4) daily flow.

RULEMAKING HEARINGS

6. The minimum dosing volume shall be determined by adding the volume of the supply line, manifold and five (5) times the volume of the laterals. If a check valve is utilized, the minimum dosing volume shall be determined by adding the volume of the manifold and five (5) times the volume of the laterals.
7. The dosing volume shall be between one-fourth (1/4) and one-half (1/2) daily flow, except in those situations where the minimum dose exceeds one-half (1/2) daily flow, then the calculated minimum dose shall be the dosing volume.

(d) Equipment and Material Specifications

1. Septic Tank and Dosing Tank
 - (i) The septic tank shall conform to all design, construction and installation criteria set forth in Rules 1200-1-6-.07 and 1200-1-6-.08.
 - (ii) The dosing chamber shall conform to all design construction and installation criteria set forth in Rule 1200-1-6-.11.
2. Pipe and Fittings
 - (i) All pipe materials shall be PVC and have a minimum equivalent strength of Schedule 40.
 - (ii) All fittings shall be pressure fittings.
 - (iii) All connections shall be adequately cleaned with cleaning solvent and glued with PVC solvent cement.
 - (iv) The gate or globe valve(s) and check valve shall be either bronze or PVC.
 - (v) The lateral pipe diameter shall be a minimum of one (1) inch.
 - (vi) The distal end of each lateral shall be equipped with a capped turnup that provides above-ground access.
3. Pump, Float Controls, and Alarm System
 - (i) The pump shall be an effluent pump of sufficient quality and size to meet or exceed the flow requirement and the total dynamic head requirement of the system.
 - (ii) The pump float controls must be adjustable and must be sealed against entry of effluent or gases.
 - (iii) Alarm System

RULEMAKING HEARINGS

- (I) A high water alarm shall be required and consist of an audible and visible alarm located in a visible place and clearly marked "wastewater system alarm."
- (II) The alarm and switches shall be placed on a separate electrical circuit from the pump power line.
- (III) The alarm float control shall be placed so as to be activated when the pump chamber water level rises above the "pump on" float control.

4. Disposal Field Media

The disposal field media size shall be within the range of one-half (1/2) to one (1) inch. It must be washed and free of fines.

(e) Installation Procedures

1. Site Preparation and Imported Fill

- (i) The soil area reserved for the initial and duplicate system must not be cut, filled, compacted or disturbed in any manner prior to or after system installation.
- (ii) No site preparation shall occur if the soil is wet. The designated person responsible for monitoring system installation shall determine when the soil is adequately dry.
- (iii) If imported fill is used during installation it must be of compatible material which shall be determined by the soil consultant approved by the department. The area to be filled must be plowed prior to adding fill. The fill material must be applied with a minimum amount of wheeled traffic and must be incorporated to ensure even mixing.

2. Supply Line and Manifold

- (i) The manifold and laterals shall be designed and installed to drain after each use.
- (ii) The supply line shall be designed and installed to drain after each use unless system design requires a check valve.
- (iii) A tee to tee connection between the manifold and laterals shall be used except in situations where the topographic, soil and other site conditions allow the manifold and laterals to be at right angles. If the manifold and laterals are at right angles then crosses or tee to tee connections may be utilized.

3. Distribution Laterals

RULEMAKING HEARINGS

- (i) The distribution laterals shall be constructed with a minimum disposal field media depth of nine (9) inches, with three (3) inches above the lateral pipe invert.
 - (ii) The disposal field media must be covered with untreated building paper, straw or other acceptable material which will allow movement of water and restrict soil movement.
4. Pump and Controls
- (i) The pump must be placed so that the intake is a minimum of eight (8) inches above the bottom of the pump chamber.
 - (ii) As a means to remove the pump from the pump chamber, a material of sufficient strength and durability must be secured to the pump and access riser.
 - (iii) The pump control must be positioned so the "pump off" switch is slightly above the top of the pump and the "pump on" switch is at the desired dosing depth.
 - (iv) The pump outlet pipe must be connected to the supply manifold with a threaded union or similar device.
 - (v) A PVC or bronze, gate or globe valve shall be placed in the supply line to adjust the specific pressure head.
 - (vi) If the effluent is pumped downhill, a five thirty second (5/32) inch siphon breaker hole must be drilled in the bottom of the supply line above the water level inside the pump tank.
 - (vii) All electrical installations shall be installed to meet the current wiring methods of the current edition of the National Electric Code (NEC) adopted by the State Fire Marshall's office.
5. The completed landscape must be shaped to prevent water from ponding or flowing over the system.
- (4) A Mound System is a soil absorption system that is located above the natural soil surface and constructed with suitable fill material. The system differs from the conventional subsurface sewage disposal system in three (3) ways: (1) uniform distribution of effluent, (2) dosing and resting cycles, and (3) above ground construction. When lots that are less than twenty thousand (20,000) square feet are proposed, the department shall determine the necessity, location and design of buffer zones. Mound systems shall not be used to dispose of wastewater wherein the average concentration of grease exceeds one hundred and fifty (150) milligrams per liter (mg/L) because of the clogging potential of the distribution network.

Mound systems designed to accommodate wastewater flows in excess of six hundred (600) gallons per day must be designed by a licensed engineer in accordance with T.C.A. §§62-2-101 et seq. The design shall be reviewed by the department applying Rule 1200-1-6-.14(2).

RULEMAKING HEARINGS

(a) Site and Soil Requirements

1. Prior to the design of the mound system, the suitability of the site must be demonstrated through acceptable soil absorption rates, acceptable soil conditions and other topographic characteristics.
2. The size of the mound system shall be determined by the following:
 - (i) An extra high intensity soil map, provided by a soil consultant approved by the department, shall establish the soil absorption rate.
 - (ii) If the extra high intensity soil map, determines that a percolation test is necessary to establish a rate, the percolation holes shall be located in a grid pattern with the maximum perpendicular distances between the holes being twenty-five (25) feet and the gridded portion shall encompass the entire area to be utilized for the system and duplicate area. Greater distances may be allowed as determined by the Commissioner. The percolation test procedure in Rule 1200-1-6-.04 of these Regulations shall apply.
 - (iii) The daily wastewater flow divided by the infiltrative capacity of medium sand (1.2 gal/ft²/day) shall determine the amount of square footage (area) required for the distribution bed.
3. The requirements relating to rock, groundwater and other site conditions established in Rule 1200-1-6-.03(2), (3) and (4) shall apply. A minimum soil depth of twenty-four (24) inches over any underlying restrictive horizon is required. However, a modified mound system may utilize up to four (4) inches of additional sand backfill reducing the minimum depth of soil to any underlying restrictive horizon to twenty (20) inches.
4. The acceptable soil absorption rate range for the mound system shall be from ten (10) minutes per inch through seventy-five (75) minutes per inch as determined by an extra high intensity soil map conducted by an approved soil consultant. If the soil absorption rate is determined to be greater than seventy-five (75) minutes per inch based upon a soils map prepared by an approved soil consultant, percolation tests may be conducted. However, soils with absorption rates in excess of seventy-five (75) minutes per inch due to wetness that cannot be corrected by drainage shall not be eligible for percolation tests. Percolation rates from seventy-six (76) minutes per inch through one hundred twenty (120) minutes per inch are acceptable if no water problems exist.
5. An area of suitable soil must be available to install the initial system and maintain a suitable area of adequate size for 100% duplication.
6. If tree stumps, or boulders are present within the areas designated for the initial and duplicate systems, adequate area must be available to compensate for the area occupied by the boulders and tree stumps.

RULEMAKING HEARINGS

7. The basal area available for a mound must be equal to or greater than the basal area required for a given soil absorption rate.
- (i) On sloping sites, the basal area available is that area directly below and downslope of the distribution bed. On level sites, the basal area available is that area below and on both sides of the distribution bed. That area below the end slopes shall not be included as available basal area.
 - (ii) The basal area required is determined by dividing the daily flow by infiltrative capacity of the soil. The infiltrative capacity of the following soils shall have the following absorption rates:

<u>Absorption Rate</u>	<u>Infiltrative Capacity Gal./ft.²/day</u>
10-29	1.2
30-60	0.74
61-120	0.24

8. Slopes steeper than twelve (12) percent shall not be utilized. Sites with soil absorption rates of sixty-one (61) through one hundred twenty (120) minutes per inch shall not exceed a slope of six (6) percent.
9. When cluster mounds are used, buffer zones are required at a frequency and size as determined by an extra high intensity soil/site evaluation.

(b) Layout of the Mound System

- 1. The mound shall be located so as to insure that the distribution bed is situated parallel to slope contour.
- 2. The location of the septic tank, dosing tank and disposal mound shall be in accordance with Rule 1200-1-6-.10 of these Regulations.
- 3. The distribution bed shall be constructed level and its thickness shall be constant. A layer of uncompacted straw six (6) inches thick, untreated building paper or acceptable synthetic fabric shall be placed between the distribution bed and the clay cap.
- 4. Configuration
 - (i) The end slope gradient of the mound shall not be steeper than three (3) horizontal to one (1) vertical. The distance from the gravel bed to the toe of the end slope is calculated by multiplying the average mound height by the horizontal slope figure.
 - (ii) The upslope and downslope gradient of the mound shall not be steeper than three (3) horizontal to one (1) vertical. The distance

RULEMAKING HEARINGS

from the gravel bed to the toe of either the upslope or the downslope side is calculated by multiplying the mound height at the appropriate edge of the gravel bed by the horizontal slope figure and then by the slope correction factor found in Table III.

- (iii) The distribution bed thickness shall be a minimum of three-fourths (3/4) feet with a minimum of one-half (1/2) feet of aggregate below the distribution network.
- (iv) The bed width shall not exceed ten (10) feet.
- (v) The sand fill thickness beneath the gravel bed shall be a minimum of one (1) foot.

TABLE III. Downslope and Upslope Width Corrections for Mounds on Sloping Sites

<u>Slope Percent</u>	<u>Downslope Correction Factor</u>	<u>Upslope Correction Factor</u>
0	1.00	1.00
2	1.06	.94
4	1.14	.89
6	1.22	.86
8	1.32	.80
10	1.44	.77
12	1.57	.73

- (vi) The cap above the distribution bed shall consist of one (1) foot of clayey subsoil at its center tapering to one-half (1/2) foot at its edges.
- (vii) The entire finished mound shall be covered with one-half (1/2) foot of soil material suitable for plant growth.

(c) **Dosing and Distribution System Design**

1. The dosing rate per linear foot of lateral shall be uniform throughout the entire distribution network.
2. Hole spacing and location shall be such so as to provide uniform distribution of effluent over the entire distribution bed. If the last hole is equal to or greater than one-half (1/2) of the hole spacing distance from the distal end of the lateral, a hole shall be placed in the end cap or adjacent to it.
3. Hole sizing, hole spacing, lateral length and lateral diameter shall be derived from Table IV. The hole diameter shall range from five thirty-second (5/32) through one-fourth (1/4) inch.
4. The system must be designed and placed so that the laterals and manifold drain after each dosing.

RULEMAKING HEARINGS

5. Calculation of gallons per minute (gpm) flow and total dynamic head (TDH).
 - (i) The gallons per minute flow, which the pump must provide, shall be determined by adding the combined gallons per minute flows of each hole.
 - (ii) The total dynamic head shall be determined by adding the following:
 - (I) Elevation head is the difference in elevation between the bottom of the pump and the laterals in the distribution bed. The minimum assigned elevation head shall be five (5) feet.
 - (II) Friction head shall be determined from Appendix III plus fittings loss.

TABLE IV. Allowable Lateral Lengths (in Feet) for Three (3) Pipe Diameters, Three (3) Perforation Sizes, and Two (2) Perforation Spacings.

Perforation spacing (in.)	Perforation Diameter (in.)	Pipe Diameter		
		(1 in.)	(1-1/4 in.)	(1-1/2 in.)
		feet	feet	feet
30	5/32	42	68	85
	3/16	34	52	70
	7/32	30	45	57
	1/4	25	38	50
36	5/32	45	70	90
	3/16	36	60	75
	7/32	33	51	63
	1/4	27	42	54

- (III) A pressure head average of three (3) feet shall be used for TDH calculations. The range shall be one (1) through five (5) feet.
6. The minimum dosing volume shall be determined by adding the volume of the supply line, manifold and five (5) times the volume of the laterals.
7. The dosing volume shall be between one-fourth (1/4) and one-half (1/2) daily flow, except in those situations where the minimum dose exceeds one-half (1/2) daily flow, then the calculated minimum dose shall be the dosing volume.

RULEMAKING HEARINGS

8. When pumping uphill, a check valve must be utilized if the volume of the supply line, manifold and the volume of the laterals that drain back into the pump tank exceeds one-fourth (1/4) of the daily flow. If a check valve is utilized, the minimum dosing volume shall be determined by adding the volume of the manifold and five (5) times the volume of the laterals.

(d) Equipment and Material Specifications

1. Septic Tank and Dosing Tank

- (i) The septic tank shall conform to all design, construction and installation criteria set forth in Rules 1200-1-6-.07 and 1200-1-6-.08.
- (ii) The dosing chamber shall conform to all design, construction and installation criteria set forth in Rule 1200-1-6-.11.

2. Pipe and Fittings

- (i) All pipe materials shall be PVC and have a minimum equivalent strength of Schedule 40.
- (ii) All fittings shall be pressure fittings.
- (iii) All connections shall be adequately cleaned with cleaning solvent and glued with PVC solvent cement.
- (iv) The gate or globe valve(s) and check valve shall be either bronze or PVC.
- (v) The lateral pipe diameter shall be a minimum of one (1) inch.
- (vi) The distal end of at least one (1) lateral shall be equipped with a capped turnout.

3. Pump, Float Controls and Alarm System

- (i) The pump shall be an effluent pump of sufficient quality and size to meet or exceed the gallons flow requirement and the total dynamic head requirement of the system.
- (ii) The pump float controls must be adjustable and must be sealed against entry of effluent or gases.
- (iii) Alarm System
 - (I) A high water alarm shall be required and consist of an audible and visible alarm located in a visible place and clearly marked "wastewater system alarm."

RULEMAKING HEARINGS

- (II) The alarm and switches shall be placed on a separate electrical circuit from the pump power line.
- (III) The alarm float control shall be placed so as to be activated when the pump chamber water level rises above the "pump on" float control.

4. Disposal Field Media

The media size shall be within the range of one-half (1/2) to one (1) inch. It must be washed and free of fines.

5. Sand

- (i) The particle sizes shall be predominantly (fifty (50%) percent or greater) medium sand (0.50 to 0.25 mm.) with no more than twenty (20%) percent fine sand (0.25 to 0.10 mm.) and be free from silt and clay.
- (ii) The sand shall be composed of stable materials and not subject to chemical deterioration.

6. Clay Cap Above the Distribution Bed - The cap shall be clayey subsoil.

7. Final Cover - The final cover shall consist of non-clayey, friable, fertile soil capable of supporting plant growth.

(e) Installation Procedures

1. Site Preparation and Imported Fill

- (i) The soil area reserved for the initial and duplicate system must not be cut, filled, compacted or disturbed in any manner prior to or after system installation.
- (ii) No site preparation shall occur if the soil is wet. The designated person responsible for monitoring system installation shall determine when the soil is adequately dry.
- (iii) All trees within the area designated for the mound shall be cut to ground level and all excess vegetation shall be removed.
- (iv) The area designated for the mound shall be plowed to a minimum depth of eight (8) inches prior to addition of the sand fill. This area shall be plowed on contour.
- (v) After any area is plowed there shall be no large equipment or wheeled traffic on or over said area. If a small tracked vehicle is used for construction there shall be a minimum of six (6) inches of sand between the track and plowed layer.

RULEMAKING HEARINGS

2. Supply Line and Manifold
 - (i) The manifold and laterals shall be designed and installed to drain after each use.
 - (ii) The supply line shall be designed and installed to drain after each use unless the system design requires a check valve.
 - (iii) The supply line shall be installed so as to prevent freezing and shall not enter from the downslope side.
 3. Pump and Controls
 - (i) The pump must be placed so that the intake is a minimum of eight (8) inches above the bottom of the pump chamber.
 - (ii) As a means to remove the pump from the pump chamber, a material of sufficient strength and durability must be secured to the pump and access riser.
 - (iii) The pump control must be positioned so the "pump off" switch is at the desired dosing depth.
 - (iv) The pump outlet pipe must be connected to the supply manifold with a threaded union or similar device.
 - (v) Immediately after the union, a gate or globe valve shall be placed in the supply line. The valve may be either PVC or bronze and shall be used to adjust the pressure on the system to the desired head.
 - (vi) If the effluent is pumped downhill, a five thirty-second (5/32) inch siphon breaker hole must be drilled in the bottom of supply line above the water level in the pump tank.
 - (vii) All electrical installations shall be installed to meet the current wiring methods of the current edition of the National Electric Code (NEC) adopted by the State Fire Marshall's office.
 4. The completed system must be shaped to prevent water from ponding or flowing over the system.
- (5) Where soil conditions preclude the use of other soil absorption systems, a Waste Stabilization Lagoon may provide satisfactory sewage treatment for residences where soils are not suited for absorption systems and flows are less than six hundred (600) gallons per day. Waste stabilization lagoons require a minimum acreage tract of five (5) acres.
- (a) Site and Soil Requirements

RULEMAKING HEARINGS

1. Prior to the design of the oxidation lagoon, the suitability of the site must be demonstrated through acceptable soil absorption rates, acceptable soil conditions and other topographic characteristics.
2. The soil characteristics shall be determined by a site investigation which includes the following elements.
 - (i) A site plan to a scale of one (1) inch equals fifty (50) feet shall show the four corners of each cell and the four (4) corners of the floor (bottom) of each cell. The four corners of the floor of the proposed lagoon shall be identified with flags or wood stakes.
 - (ii) A minimum of four (4) borings shall be made to a minimum of five (5) feet. One (1) boring shall be made in the floor of the lagoon near each stake or flag.
 - (iii) Additional borings shall be made in the side slopes (walls) of the wetted area of the lagoon to determine that the site has acceptable soil conditions and that the site is free of rocks to a depth of one (1) foot or more below the bottom of the wetted area of the lagoon.
 - (iv) The soil notes shall state the soil color, including mottles; the texture, including coarse fragments and consistence for each layer in the soil.
 - (v) The absorption rate may be estimated by an approved soil consultant but may require approval by the department. Where the estimated absorption rate has been determined to be less than one hundred twenty (120) minutes per inch by an approved soil consultant, absorption rates shall be established by a percolation test. The percolation holes shall be located in a grid pattern with maximum perpendicular distances between holes being twenty-five (25) feet and the gridded portion shall encompass the entire area to be utilized for the system and duplicate area. The percolation test holes shall be dug to a depth equivalent to the total depth of the anticipated oxidation lagoon. The water level shall be adjusted three (3) feet from the bottom of the hole. All other portions of the percolation test procedure in Rule 1200-1-6-.04 of these Regulations shall apply.
 - (vi) The depth of the seasonal high water table shall be noted if it is located within six (6) feet of the soil surface.
3. The soil percolation rate must be a minimum of one hundred twenty (120) minutes per inch.
4. Adequate suitable soil must be available to install the initial system and reserve an area of equal size.
5. The lagoon shall be located in soils where the vertical separation from the bottom of the lagoon and bedrock and rock formations are a minimum of one (1) foot.

RULEMAKING HEARINGS

6. The minimum operating level of the lagoon shall be located above the seasonal high ground water level. The lagoon shall not be located in areas subject to flooding as determined by the department.
 7. Slopes greater than eight (8) percent shall be considered unsuitable.
 8. Selection of the site shall include a clear sweep of the surrounding area by prevailing winds. Heavy timber must be removed for a distance of one hundred (100) feet from the water's edge to enhance wind action and prevent shading.
 9. Areas consisting of fill shall be excluded from the area considered for installation of the oxidation lagoon and disposal field.
 10. Lot Grading - The area to be used for the oxidation lagoon and disposal field shall not be disturbed when grading the lot. However, where this is unavoidable, a re-evaluation shall be made by an approved soil consultant after grading has been completed. After the suitability of any area to be used for an oxidation lagoon has been evaluated and approved for construction, no change shall be made to this area unless the Commissioner is notified and a re-evaluation of the area's suitability is made prior to the initiation of construction.
- (b) Location - A minimum acreage tract of five (5) acres is required and larger areas may be necessary.
1. Minimum Separation Distances
 - (i) The lagoon shall be located a minimum of fifty (50) feet from property lines, as measured from the lagoon shoreline.
 - (ii) The lagoon shall be located a minimum of two hundred (200) feet from the nearest residence, commercial or industrial establishments, any habitable building or public use area. With the owner's permission the lagoon may be within a lesser distance of his home.
 - (iii) The lagoon shall not be located closer than fifty (50) feet away from any spring or well. Greater horizontal separation distances may be required depending on engineering and hydrogeological data and type of water supply.
 - (iv) The lagoon shall not be closer than fifty (50) feet away from a stream, lake or impoundment.
 - (v) The lagoon shall not be located closer than fifty (50) feet from gullies, ravines, dry stream beds, natural drainageways, sinks, caves and cut banks.
- (c) Design of the Oxidation Lagoon

RULEMAKING HEARINGS

1. The capacity of a two (2) cell lagoon shall be equivalent to a sixty (60) day minimum retention time based upon the average daily sewage flow of one hundred and fifty (150) gallons per bedroom for residences. The minimum water surface area of both cells shall be one thousand two hundred and fifty (1,250) square feet.
2. A properly sized and constructed two (2) compartment septic tank shall precede the lagoon.
3. The inner embankment of the lagoon shall be lined with soil, which has a clay content of thirty-five (35) percent or more. The liner shall have a minimum thickness of six (6) inches after compaction.
4. The shape of the lagoon shall be such that there are no narrow or elongated portions. Round, square, or rectangular cells are considered most desirable. Rectangular cells shall have a length not exceeding three (3) times the width. No islands, peninsulas, or coves shall be permitted. Embankments must be rounded at corners to minimize accumulations of floating materials.
5. The embankment top width shall be a minimum of two (2) feet.
6. The embankment slopes shall not be steeper than two (2) horizontal to one (1) vertical on the inner and outer sides.
7. Inner embankment slopes shall not be flatter than three (3) horizontal to one (1) vertical. Outer embankment slopes shall be sufficient to prevent the entrance of surface water into the lagoon.
8. Freeboard (the distance from the top of the water to the top of the embankment) shall be at least two (2) feet after settling. Additional freeboard may be provided.
9. Embankments shall be seeded with a locally hardy grass from the outside toe to the water line, to minimize erosion and facilitate weed control. Alfalfa or similar long-rooted crops which may interfere with the water holding capacity of the embankment shall not be used. Riprap may be necessary under unusual conditions to provide protection of embankments from erosion.
10. On sloping areas, a diversion ditch or soil improvement practices shall be located immediately upslope from the embankment. The ditch or soil improvement practice shall be installed to intercept and remove all surface and subsurface water and shall be protected from erosion.
11. The gravity flow lagoon influent line shall be Schedule 40 PVC or equivalent and have a minimum diameter of three (3) inches with a minimum grade of one-fourth (1/4) inch per foot. When gravity flow is utilized, the outlet invert of the septic tank shall be a minimum of one (1) foot above the high water level in the lagoon. The water level of each cell shall be at an elevation lower than the original ground surface.

RULEMAKING HEARINGS

12. The influent line shall be center discharging at a point two (2) feet beneath the water level. A watertight cleanout shall be provided in the influent line near the lagoon embankment and shall extend upwards to finished grade.
 13. The effluent line from each cell shall be designed to maintain the water level of that cell at a depth of four (4) feet and be located so as to minimize short-circuiting from the influent line.
 14. The effluent from the second cell shall be disposed of by a subsurface sewage disposal system.
 15. The subsurface sewage disposal system shall be constructed according to Rule 1200-1-6-.06(4) of these Regulations and shall require a minimum of one hundred and fifty (150) square feet of soil absorption trench bottom area.
 16. The finished grade above the subsurface sewage disposal system shall be lower in elevation than the invert of the effluent discharge line from the last cell.
- (d) Dosing of the System (applicable only when pumping is necessary).
1. If pumping to the lagoon is necessary, the total dynamic head (TDH) shall be determined by the elevation head, friction head and three (3) feet of pressure head.
 2. The gallons per minute (gpm) flow amount, which the pump must provide shall be a minimum of ten (10) gpm.
 3. The dosing volume shall be less than one-half (1/2) daily flow.
 4. A check valve must be utilized when pumping uphill.
- (e) Equipment and Material Specifications
1. Septic tank and dosing tank.
 - (i) The septic tank shall conform to all design, construction and installation criteria set forth in Rules 1200-1-6-.07 and 1200-1-6-.08.
 - (ii) The dosing chamber shall conform to all design, construction and installation criteria set forth in Rule 1200-1-6-.11.
 2. Pipe Materials
 - (i) All pipe materials shall be PVC and have a minimum equivalent strength of Schedule 40 PVC.
 - (ii) If pumping is necessary, all fittings shall be pressure fittings.

RULEMAKING HEARINGS

- (iii) All connections shall be adequately cleaned with cleaning solvent and glued with PVC solvent cement.

(f) Construction

1. The area designated for the lagoon liquid storage area and embankments shall be stripped of vegetation. The organic material removed during excavation of the lagoon shall not be used in embankment construction.
2. The area designated for the lagoon liquid storage area and embankments shall be stripped of soils that will not form an effective seal.
3. The liquid storage area of the lagoon must be sealed to prevent excessive exfiltration.
4. Embankments shall be constructed of impervious materials, and compacted sufficiently to form a stable structure.
5. The influent line shall be installed at sufficient depth to protect the line from freezing and be properly bedded to prevent structural damage to the pipe from wheeled vehicles that cross the area. Slope of the line shall be such that excessive flow velocities do not cause scouring at the discharge point, but shall be adequate to prevent deposition within the line.
6. Effluent from the last cell shall be withdrawn from six (6) inches below the water surface. This shall be accomplished by placing a tee, with the run in a vertical position, on the inlet end of the effluent pipe.
7. The lagoon area shall be enclosed with a minimum four (4) feet high woven or chain-link fence to preclude livestock and discourage trespassing. The fence shall be so located to permit mowing of the embankment top and slopes. A gate of sufficient width to accommodate mowing equipment shall be provided.
8. Appropriate warning signs shall be provided to designate the nature of the facility and discourage trespassing.

(g) Operation and Maintenance

1. It shall be necessary to fill the lagoon with water prior to using it for waste disposal.
2. Vegetation growing along the water's edge and in the water shall be mowed or otherwise removed at least annually.
3. It shall be necessary to maintain a consistent water depth of four (4) feet at all times of the year.

- (6) A Large Diameter Gravelless Pipe (LDGP) system is a subsurface sewage disposal system which has one (1) basic design principle different from conventional subsurface sewage disposal systems, which is that an eight (8) or ten (10) inch inside diameter corrugated

RULEMAKING HEARINGS

polyethylene perforated pipe is used for the storage and distribution of effluent in a trench in lieu of a four (4) inch diameter pipe and gravel. A filter, fabric wrap around the pipe prevents soil infiltration into the pipe; prevents small, suspended solids from moving out of the pipe; and the pipe volume provides storage capacity equal to or slightly greater than a conventional gravel trench.

LDGP systems that exceed seven hundred fifty (750) linear feet of ten (10) inch diameter pipe or one thousand one hundred and twenty-five (1,125) linear feet of eight (8) inch diameter pipe shall meet the minimum requirements established in Rule 1200-1-6-.06(3)(c).

(a) Site and Soil Requirements

1. The site and soil requirements are the same as for a conventional subsurface sewage disposal system. Where the soil absorption rate exceeds sixty (60) minutes per inch, gravel backfill, leveled with the top of the LDGP, shall be required in accordance with Rule 1200-1-6-.06(4)(j) and (m) and a trench width of twenty-four (24) inches.
2. An area of suitable soil must be available equivalent in size to that necessary to install and duplicate a conventional subsurface sewage disposal system.
3. The size of the LDGP system shall be determined by the following:
 - (i) The soil series shall determine the soil absorption rate found in Appendix I except those series or variants thereof to which a different soil absorption rate has been assigned based on soil properties determined during soil evaluations by a soil consultant approved by the department. The rate found in Table V shall determine the size of the LDGP system. Should a rate not be established for a particular soil series, the rate for that series shall be established by the department.
 - (ii) On individual lots where the Commissioner determines site suitability, an established soil absorption rate up to and including seventy-five (75) minutes per inch may be established. The size of the LDGP system shall be determined by the rate found in Table V.
 - (iii) Where percolation tests are required, the size of the LDGP shall be determined by the rate found in Table V.

RULEMAKING HEARINGS

TABLE V. Soil Absorption Rates and Corresponding Trench Length Requirements for LDGP Systems

ABSORPTION RATE IN MINUTES PER INCH	TRENCH LENGTH IN LINEAR FEET/GALLON		TRENCH LENGTH IN FEET PER BEDROOM	
	8" Pipe	10" Pipe	8" Pipe	10"Pipe
10	0.600	0.400	83	55
15	0.700	0.467	95	64
30	1.000	0.667	125	84
45	1.250	0.834	150	100
60	1.450	0.967	165	110
75	1.600	1.067	185	124
80	1.650	1.100	190	126
85	1.700	1.134	195	130
90	1.750	1.167	200	134
95	1.800	1.200	208	139
100	1.850	1.234	215	144
105	1.900	1.267	223	149

EXAMPLES:

1. The soil absorption rate is thirty (30) minutes per inch. A three (3) bedroom home is to be located on this site. If an eight (8) inch inside diameter pipe is used, then three (3) bedrooms x one hundred and twenty-five (125) feet/bedroom = three hundred and seventy-five (375) linear feet of trench needed.
2. The soil absorption rate is ninety-five (95) minutes per inch. A four (4) bedroom house is to be located on this site. If a ten (10) inch inside diameter pipe is used, then four (4) bedrooms x one hundred and thirty-nine (139) feet/bedroom = five hundred and fifty-six (556) linear feet of trench needed.
3. The soil absorption rate is forty-five (45) minutes per inch. A commercial building generating five hundred (500) gallons of wastewater per day is to be located on this site. If a ten (10) inch inside diameter pipe is used, then five hundred (500) gallons x eight hundred and thirty-four one thousandths (0.834) feet/gallon = four hundred and seventeen (417) linear feet of trench needed.
4. The soil absorption rate is eighty-five (85) minutes per inch. An industrial plant generating three hundred and seventy-five (375) gallons of wastewater per day is to be located on this site. If an eight (8) inch inside diameter pipe is used, then three hundred and seventy-five (375) gallons x one and seven tenths (1.700) = six hundred and thirty-eight (638) linear feet of trench needed.

(b) Layout of the LDGP System

RULEMAKING HEARINGS

1. The linear footage required is determined from Table V.
2. The location of the septic tank and the disposal field shall be in accordance with Rule 1200-1-6-.10 of these Regulations.
3. The lateral lines shall be placed on contour. The maximum length of a single line should not exceed one hundred (100) feet unless conditions require a longer line.
4. The trench bottom of each lateral shall have a grade from level to no greater than two (2) inches per one hundred (100) feet.
5. A minimum of six (6) feet of undisturbed earth between adjacent trench walls shall be required.
6. Trench width shall be a minimum of eighteen (18) inches and a maximum of twenty-four (24) inches with the maximum trench width being required when the soil absorption rate exceeds sixty (60) minutes per inch.
7. Trench depth shall range between twenty-two (22) and forty-eight (48) inches for eight (8) inch pipe and twenty-four (24) and forty-eight (48) inches for ten (10) inch pipe.
8. The large diameter pipe shall be positioned in the trench so that the top location stripe is on top. Sections of pipe shall be securely joined and the filter wrap must cover all joints and the ends of each line. All couplings and/or connections must be accomplished with material/fittings manufactured specifically for large diameter gravelless pipe. Where a supply or tight line ties into the side of a large diameter gravelless pipe, the supply line or tight line shall not penetrate the pipe more than two (2) inches.
9. Soil material excavated from trenches should be used in backfilling and should be left mounded over the trenches until initial settling has taken place.
10. The invert of the overflow pipe in the first relief line shall be at least four (4) inches lower than the invert of the septic tank outlet. The trench for the relief pipe, where it connects with the preceding large diameter gravelless pipe, shall be dug no deeper than the top of the large diameter gravelless pipe. In a recirculating design, the top of the pipe must be a minimum of one (1) inch below the invert of the septic tank outlet.

(c) Equipment and Material Specifications

1. Septic Tank (Rules 1200-1-6-.07 and 1200-1-6-.08 shall apply)
2. Pipe
 - (i) The eight (8) and ten (10) inch inside diameter tubing shall be corrugated polyethylene, meeting the requirements of ASTM F667, Standard Specification for Large Diameter Corrugated Polyethylene Tubing.

RULEMAKING HEARINGS

- (ii) Perforations shall be cleanly cut and uniformly spaced along the length of the tubing as follows: two (2) rows of three-eighths (3/8) to one-half (1/2) inch diameter holes located 115° - 125° apart along the bottom half of the tubing with each row of holes 57.5° - 62.5° up from the bottom centerline. These perforations should be staggered so that there is only one (1) hole in each corrugation. Perforations must be located in the minimum diameter portions of the pipe.
 - (iii) The tubing shall be marked with an easily visible top location stripe.
3. Filter Wrap - All large diameter pipe shall be encased with a spun bonded nylon, or other material of similar strength and durability. If the filter wrap is installed at the point of manufacture, then the corrugated pipe and filter wrap shall be shipped in a protective covering that will prevent damage to the filter wrap. This wrap shall meet or exceed the following general qualities:

<u>Physical Properties</u>	<u>Minimum Values</u>
Weight (oz./sq.yd.)	0.75
Thickness (mils.)	4.4
Grab Strength (lbs.)	
Machine Direction	19
Transverse Direction	11
Burst strength (psi)	26
Air Permeability (cfm/sq.ft.)	500
Water Flow Rate (gpm/sq.ft. at 3" head)	200

(7) A chamber system is a media replacement system consisting of a high density polyethylene arch-shaped open bottomed chamber. Chamber systems that exceed seven hundred fifty (750) linear feet in a single system, or five hundred twenty-five (525) linear feet where the soil absorption rate is sixty (60) minutes per inch or less, shall meet the minimum requirements established in Rule 1200-1-6-.06(3)(c).

- (a) Site and Soil Requirements
 - 1. The site and soil requirements are the same as for a conventional subsurface sewage disposal system.
 - 2. An area of suitable soil must be available equivalent in size to that necessary to install and duplicate a conventional subsurface sewage disposal system.
- (b) Layout of the Chamber System

RULEMAKING HEARINGS

1. The size of a chamber system shall be equivalent to the total linear footage required for a three feet wide conventional subsurface sewage disposal system. However, where the soil absorption rate is from ten (10) to sixty (60) minutes per inch, the total linear footage may be reduced by thirty (30) percent. If a portion of a unit is left over after determining the total linear footage required, round up to the nearest whole unit.
2. The location of the septic tank and the disposal field shall be in accordance with Rule 1200-1-6-.10 of these Regulations.
3. The lateral lines shall be placed on contour. The maximum length of a single line should not exceed one hundred (100) feet unless conditions require a longer line.
4. The trench bottom of each lateral shall have a grade from level to no greater than two (2) inches per one hundred (100) feet.
5. A minimum of six (6) feet of undisturbed earth between adjacent trench walls shall be required.
6. Trench width shall be thirty-six (36) inches.
7. Trench depth shall range from twenty-four (24) to forty-eight (48) inches.
8. Soil material excavated from trenches should be used in backfilling and should be left mounded over the trenches until initial settling has taken place.
9. The top of the chambers shall be below the invert of the septic tank outlet.
10. The trench for the relief pipe, where it connects with the preceding absorption trench, shall be dug no deeper than the invert of the opening in the end plate.

(c) Equipment and Material Specifications

1. Septic Tank (Rules 1200-1-6-.07 and 1200-1-6-.08 shall apply)
2. Each chamber shall measure from thirty-two (32) to thirty-six (36) inches wide and ten (10) to twelve (12) inches high. Chambers of varying heights and widths may be approved on an individual basis by the Division of Ground Water Protection Central Office.
3. Each chamber must be designed to interlock with adjacent chambers, inlet plate or end plate forming a complete disposal trench that consists of an inlet plate with a splash plate located below the inlet on the trench bottom and a solid end plate to be located at the distal end of each terminal trench.
4. The chamber sidewall must be designed to allow effluent to pass laterally into the soil.

RULEMAKING HEARINGS

Authority: T.C.A. §§68-221-403, 4-5 et seq.

1200-1-6-.15 EXPERIMENTAL METHODS OF TREATMENT AND DISPOSAL OTHER THAN THOSE PROVIDED IN THESE REGULATIONS.

- (1) Experimental methods of treatment and disposal of sewage in lieu of those provided herein shall not be utilized unless approval has been granted by the department.
- (2) Prior to issuance of an experimental sewage system permit, a restrictive covenant shall be completed, notarized and recorded at the Register of Deeds Office in the county where the system will be located. A copy of such shall be submitted to the department.

Authority: T.C.A. §§68-13-403.

1200-1-6-.16 PRIVIES AND COMPOSTING TOILETS.

- (1) Pit privies shall be constructed to prevent a health hazard and prevent insect and rodent accessibility, and shall not be located less than fifty (50) feet from a water supply or less than ten (10) feet from any habitable building or property line.
- (2) Composting toilets must be certified by the National Sanitation Foundation (NSF) to be in compliance with NSF Standard 41, and be published in their "Listing of Certified Wastewater Recycle/Reuse and Water Conservation Devices," before they may be used for disposal of human excreta by non-water carriage methods.
- (3) A pit privy or composting toilet shall not be permitted for a facility where the facility has running water available unless there is an acceptable means to dispose of wastewater.

Authority: T.C.A. §§68-221-403, 4-5 et seq.

1200-1-6-.17 APPROVED SOIL CONSULTANTS.

- (1) An approved soil consultant shall be one who meets all of the following requirements:
 - (a) Graduation from an accredited college or university with a bachelor's degree in soil science, agronomy and/or agriculture with an emphasis in plant and soil science or agronomy OR graduation from an accredited college or university with a minimum of thirty (30) quarter hours biological, physical and earth sciences and an additional 22.5 quarter hours in soil science.
 - (b) A minimum of two (2) years full time or equivalent of soil evaluation experience in accordance with the United States Department of Agriculture system. Experience must include studies of soil physical characteristics, geology, and soil relationships, soil-landscape relationships, soils identification, landscape features, mapping techniques, interpretive ranges, sewage systems and soil improvement design variations.

RULEMAKING HEARINGS

- (c) Candidates must pass a written examination to demonstrate mastery in soil science. A test result of eighty (80) percent correct shall constitute a passing score.
 - (d) Candidate must pass a field soil mapping test to demonstrate mastery in soil classification, soil mapping, soil interpretations and cartography skills. A score of eighty (80) is satisfactory. Candidate then receives interim approval as a soil consultant.
 - (e) After completing the first five (5) soil maps, if no serious errors were made, the candidate then becomes a soil consultant approved to make general and high intensity soil maps.
 - (f) If the candidate fails the written examination, the field test or any of the first five (5) soil maps, the testing procedure may begin again after a six (6) month period. The second time, if the candidate fails the written test, the field mapping test or any of the first five (5) high intensity soil maps, the testing procedure may begin again after a twelve (12) month waiting period. The testing procedure may be repeated only one time.
 - (g) After a period of one year and the completion of a minimum of twenty-five (25) high intensity soil maps with a total of one hundred (100) acres, and approved soil consultant who has not been reprimanded or suspended may apply to become approved to make all intensity soil maps.
 - (h) Soil maps shall be made to comply with criteria set forth by the most current edition of "The Soils Handbook For Tennessee" prepared by the Division of Ground Water Protection.
- (2) Revocation of Approval
- (a) The department may revoke or suspend the approval of any soil consultant for the practice of any fraud or deceit in obtaining the approval or any gross negligence, incompetence or misconduct in the practice of soil evaluation or any continued disregard of evaluation criteria as required by "The Soils Handbook For Tennessee" prepared by the Division of Ground Water Protection. Any person whose approval as a soil consultant has been denied, suspended, or revoked, may request a hearing before the Commissioner by making such request in writing within thirty (30) days of the date of his denial, suspension, or revocation. Any hearing granted under this section shall be conducted in accordance with the Uniform Administrative Procedures Act, compiled in Title 4, Chapter 5, Part 3 of Tennessee Code Annotated.

Authority: T.C.A. §§68-221-403, 4-5 et seq.

1200-1-6-.18 INSTALLER OF SUBSURFACE SEWAGE DISPOSAL SYSTEMS.

- (1) No person shall engage in the business of constructing, installing, altering, or extending or repairing a subsurface sewage disposal system unless he has a valid annual permit issued by the Commissioner. This section does not apply to the property owner or the property owner's tenant doing his own work on his own property where such property is the residence of the owner or tenant, provided that nothing in this subsection shall act to remove the

RULEMAKING HEARINGS

requirement that any person must secure a construction permit as provided by law and duly promulgated Regulations.

- (a) Any person who is, on the effective date of these Regulations, or intends to become after the effective date of these Regulations, an installer, shall make application for the installer's permit in writing on a form furnished by the department.
- (2) No permit under this section shall be granted until:
- (a) An application is filled out in its entirety, unless otherwise specified by the Commissioner; and
 - (b) The installer scores a grade of seventy (70) percent or above on a written or oral test developed by the department. This test requirement does not apply, however, to an installer who was licensed the previous year and who performed satisfactory work, as determined by the Division of Ground Water Protection, during the previous year. The test shall cover design, location and installation of conventional/alternative subsurface sewage disposal systems; and
 - (c) A permit to install subsurface sewage disposal systems may be denied where the applicant has had a previous permit denied, suspended or revoked due to unsatisfactory work, where such unsatisfactory work is material to the subject matter of the permit.
- (3) Permits shall not be transferable or assignable and shall automatically become invalid upon a change of ownership or upon suspension or revocation.
- (4) When a permit has been denied, suspended or revoked, a hearing may be requested before the Commissioner by making such request in writing within thirty (30) days of the date of his denial, suspension, or revocation. Any hearing granted under this section shall be conducted in accordance with the Uniform Administrative Procedures Act, compiled in Title 4, Chapter 5, Part 3 of Tennessee Code Annotated.
- (5) Permits shall expire on the 31st day of December following the date of issuance.
- (6) An application for a permit shall contain the following:
- (a) Name of business.
 - (b) Business address and phone number.
 - (c) Owner's name.
 - (d) Address and phone number of owner.

Authority: T.C.A. §§68-221-403, 4-5 et seq..

RULEMAKING HEARINGS

1200-1-6-.19 SEPTIC TANK PUMPING CONTRACTOR.

- (1) Domestic Septage Removal Permit - Persons engaged in the business of removing and disposing of domestic septage from septic tanks, holding tanks, portable toilets, or other similar sewage treatment or disposal facilities covered within the provision of these Regulations shall obtain an annual permit from the Commissioner.

Septic tank pumping contractors are authorized under the domestic septage removal permit to pump the contents of grease traps that are a part of subsurface sewage disposal systems. This grease trap waste must be disposed of in a manner approved by the Commissioner. Grease trap waste may not be disposed of on a domestic septage disposal site, as authorized under these Regulations.

- (2) No permit under this section shall be granted until:
 - (a) An application is filled out in its entirety, unless otherwise specified by the Commissioner; and
 - (b) The contractor has demonstrated to the Commissioner that he is capable of conducting the operation in accordance with the Regulations as set forth herein.
 - (c) A domestic septage removal permit may be denied where the applicant has had a previous permit denied, suspended or revoked due to unsatisfactory work, where such unsatisfactory work is material to the subject matter of the permit.
- (3) Application for permit shall contain the following:
 - (a) Business name, owner's name, address and telephone number.
 - (b) Signature of applicant and date of application.
 - (c) Written permission of the proper official when contents are to be disposed of by discharging into a public or community wastewater treatment plant.
 - (d) Written permission of the landowner, and disposal site operator, if different from the landowner, for each land application site used, including a copy of the domestic septage disposal site permit(s).
 - (e) Tank capacity, in gallons, license number and state of registration for each vehicle used to transport domestic septage.
 - (f) Counties in which the contractor intends to conduct most of his business.
- (4) Monitoring Logs - A monthly log, on a form provided by the Department, of all pumpings and discharges shall be maintained. The log shall include, but not be limited to, the following:
 - (a) Date domestic septage is collected.
 - (b) Address of collection.
 - (c) Indicate if collection point is residential or commercial.

RULEMAKING HEARINGS

- (d) Volume in gallons collected.
 - (e) Type of waste hauled.
 - (f) The discharge location, by treatment plant name or land disposal site permit number.
 - (g) The date, time and total number of gallons of domestic septage applied to the approved disposal site (if applicable).
 - (h) Method of pathogen reduction and vector attraction reduction for each load (if applicable).
 - (i) The following statement of certification:

"I certify, under penalty of law, that all domestic septage has been disposed of at an approved wastewater treatment facility, or that the site requirements in the Regulations To Govern Subsurface Sewage Disposal Systems, Section 1200-1-6-.20(6) have been met."
- (5) Vehicle Identification - All vehicles engaged in domestic septage removal shall carry on both sides of the vehicle the name and address of the firm or operator conducting the business and the domestic septage removal permit number under which the business is being conducted. All lettering shall be at least two (2) inches high in bold print on a background of contrasting colors. All vehicles used for transporting domestic septage shall have an identifying sticker, provided by the department, attached to the vehicle in a location determined by the department.
- (6) Vehicle Maintenance - Every vehicle used for domestic septage removal purposes shall be equipped with a watertight tank and shall be maintained in a clean and sanitary condition. Liquid wastes shall not be transported in an open body vehicle unless contained within suitable portable receptacles. All pumps, valves and hose lines shall be maintained so as to prevent leakage. A splash plate or other approved method of dispersal shall be used for land application.
- (7) Portable Receptacles - All portable receptacles used for transporting liquid or solid wastes shall be watertight, equipped with tight-fitting lids, and cleaned daily.
- (8) Domestic Septage Removal Permit
- (a) Permits shall not be transferable or assignable and shall automatically become invalid upon a change of ownership or upon suspension or revocation.
 - (b) Permits shall expire on the 31st day of December, following the date of issuance.
 - (c) When a permit has been denied, suspended, or revoked, a hearing may be requested before the Commissioner by making such request in writing within thirty (30) days of the date of the denial, suspension or revocation. Any hearing granted under this section shall be conducted in accordance with the Uniform Administrative Procedures Act, compiled in Title 4, Chapter 5, Part 3 of Tennessee Code Annotated.

Authority: T.C.A. §§68-221-403, 4-5 et seq.

RULEMAKING HEARINGS

1200-1-6-.20 DOMESTIC SEPTAGE DISPOSAL.

- (1) When permission for use is obtainable, a public, or community, or private wastewater treatment facility shall be used to dispose of domestic septage. When permission to use wastewater treatment facilities cannot be obtained, then a permitted domestic septage disposal site may be used in accordance with this rule. A domestic septage disposal site permit shall be obtained from the Commissioner.
- (2) Domestic Septage Disposal Site Permit - Any site used for the disposal of the domestic septage from septic tanks or other sewage treatment or disposal facilities covered within the provisions of these Regulations shall require an annual permit from the Commissioner. The operator of the site shall obtain this permit prior to any use of the site and shall be responsible for the proper use and maintenance of the site.
- (3) No permit under this section shall be granted until:
 - (a) An application is filled out in its entirety, unless otherwise specified by the Commissioner; and
 - (b) The operator has demonstrated to the Commissioner that he is capable of operating the site in accordance with the Regulations as set forth herein; and
 - (c) The department has determined that the site meets the minimum requirements as set forth herein.
 - (d) A domestic septage disposal site permit may be denied, suspended, or revoked when the disposal site does not meet the minimum requirements as set forth herein or where it is determined that the operator is not operating the site in accordance with the Regulations as set forth herein.
- (4) Application for permit shall contain the following:
 - (a) Business name, address and telephone number of operator.
 - (b) Name, address and telephone number of applicant.
 - (c) Written permission of the landowner. The landowner must agree, in writing, to abide by the land use restrictions as provided in the Regulations.
 - (d) A high intensity soil map of the proposed disposal area prepared in accordance with Rules 1200-1-6-.02(3)(a)(1)(i) and 1200-1-6-.02(3)(a)(2)(i) of these Regulations. This map must note any areas where slope exceeds twelve (12) percent or where there is less than twenty-four (24) inches of soil material before subsurface bedrock formations, fragipans, seasonal high water table, or water are encountered.
 - (e) A plat, with seal and signature of a registered surveyor, of sufficient scale and accuracy to locate pertinent features. This plat shall include, but not be limited to, the property boundaries, disposal boundaries, buildings, underground utilities, roads, surface waters, water supplies, water courses, sinks, sinkholes, caves, etc.
 - (f) The crop to be grown on the disposal site for the coming year.

RULEMAKING HEARINGS

- (g) Any additional information that the Commissioner determines is necessary to properly evaluate the site.
- (5) Permits for Domestic Septage Disposal Site.
- (a) Permits shall not be transferable or assignable and shall automatically become invalid upon a change of land or business ownership or upon suspension or revocation.
 - (b) Permits shall expire on the 31st day of December, following the date of issuance.
 - (c) When a permit has been denied, suspended, or revoked, a hearing may be requested before the Commissioner by making such request in writing within thirty (30) days of the date of the denial, suspension, or revocation. Any hearing granted under this section shall be conducted in accordance with the Uniform Procedures Act, compiled in Title 4, Chapter 5, Part 3 of *Tennessee Code Annotated*.
- (6) Land application of domestic septage may be approved as follows:
- (a) The pH of the domestic septage shall be raised to a minimum of twelve (12) or higher by the addition of an alkali such as hydrated lime or quicklime, and without adding more alkali, the domestic septage shall remain at a pH of twelve (12) or higher for at least thirty (30) minutes prior to being land applied; or
 - (b) Domestic septage shall be injected below the surface of the soil. When domestic septage is injected below the surface of the soil, no significant amount of domestic septage shall be present on the surface of the soil within one (1) hour after the domestic septage is injected; or
 - (c) Domestic septage shall be incorporated into the surface of the soil within six (6) hours of land application.
 - (d) The vehicle must be in motion during land application to evenly distribute the domestic septage over the site. A splash plate or other approved method of dispersal shall be used for land application.
 - (e) Grease and/or the contents of grease traps shall not be disposed of at any domestic septage disposal site approved under these rules.
 - (f) Commercial or industrial wastewater shall not be disposed of at any domestic septage disposal site approved under these rules.
 - (g) The contents of portable toilets, Type III marine sanitation devices, or similar materials shall not be applied to domestic septage disposal sites unless the site is approved in conjunction with the Division of Ground Water Protection Central Office.
- (7) Site Restrictions
- (a) Soil requirements:
 - 1. Domestic septage disposal sites shall have a slope of twelve (12) percent or less.

RULEMAKING HEARINGS

2. The soil material in the domestic septage disposal site shall be at least twenty-four (24) inches deep before subsurface rock formations or seasonal ground water is encountered.
3. Domestic septage disposal sites shall have a well-established sod cover unless domestic septage is injected below the soil surface or incorporated into the soil surface within six (6) hours of land application.
4. The minimum soil absorption rate shall be thirty (30) minutes per inch. There are no upper limits on soil absorption rates.

- (b) The annual application rate for domestic septage shall not exceed the annual application rate calculated using the equation:

$$\text{AAR} = \frac{\text{N}}{0.0026}$$

Where:

AAR = Annual application rate in gallons per acre per 365 day period.

N = Amount of nitrogen in pounds per acre per 365 day period needed by the crop or vegetation grown on the land.

Once the annual application rate has been reached for an approved domestic septage disposal site, no additional domestic septage disposal will be allowed on that site during that calendar year.

- (c) The location of the disposal site shall be selected in accordance with the following minimum distances:
1. Five hundred (500) feet from any habitable building or public use area. With the owner's permission, the site may be within a lesser distance of his residence.
 2. One hundred (100) feet from adjoining property, any highway or public road, sink, cave or bedrock outcrop.
 3. Three hundred (300) feet from surface waters or any point where it can pollute any water course or groundwater.
 4. Five hundred (500) feet from water supplies or bathing areas.
 5. No disposal in areas subject to flooding, as determined by the department.
- (d) Grazing restrictions - Animals shall not be allowed to graze on the land for thirty (30) days after application of domestic septage.
- (e) Public access to the domestic septage disposal site shall be restricted for one year after application of domestic septage. Examples of restricted access include remoteness, posting "no trespassing" signs, and/or simple fencing.

RULEMAKING HEARINGS

- (f) Crop restrictions:
 - 1. Food crops with harvested parts that touch the domestic septage/soil mixture and are totally above ground shall not be harvested for fourteen (14) months after application of domestic septage.
 - 2. Food crops with harvested parts below the surface of the land shall not be harvested for thirty-eight (38) months after application of domestic septage.
 - 3. Animal feed, fiber, and those food crops that do not touch the soil surface shall not be harvested for thirty (30) days after application of domestic septage.

(8) Facility Standards

- (a) Storage facilities shall be identified and approved and must be used if pumping is continued when the site is not accessible or usable.
- (b) Mixing facilities for lime and domestic septage shall be identified, inspected, and approved by the Commissioner.
- (c) Mixing tanks must be watertight, structurally sound, and not subject to excessive corrosion or decay.

Authority: T.C.A. §§68-221-403, 4-5 et seq.

1200-1-6-.21 FEES FOR SERVICES.

- (1) Fees for services are assessed pursuant to the following:

<u>Specific Procedure Covered by Fee</u>	<u>Fee</u>
(a) General intensity mapping to determine eligibility for percolation tests.	Eighty (\$80.00) dollars per acre, with Eighty (\$80.00) dollars being the minimum for each separate acre or part of acre to be mapped.
(b) High intensity mapping (sufficient for final approval, 1" = 100' scale) of single lots, or tracts where lots have been staked, or where tracks are gridded (100' grid staking) for residential, commercial, industrial, institutional or recreational users.	Two hundred (\$200.00) dollars per acre, with two hundred (\$200.00) dollars being the minimum for each separate acre or part of acre to be mapped.
(c) Extra-high intensity mapping for alternative disposal system.	Two hundred fifty (\$250.00) dollars per acre with two hundred fifty (\$250.00) dollars being the minimum for each separate acre or part of acre to be mapped.

RULEMAKING HEARINGS

- (d) Conventional, chamber and large diameter gravelless pipe subsurface sewage disposal systems permit application processing, making inspections and other regulatory activities relative to the construction of new conventional, chamber and large diameter gravelless pipe subsurface sewage disposal systems and expansion of system because of additions resulting in added wastewater flow and for repair of malfunctioning systems. Permits shall be granted or denied within forty-five (45) days of receipt of all necessary information. Two hundred fifty (\$250.00) dollars up to (1,000) gallons per day (g.p.d.) design flow plus two hundred fifty (\$100.00) dollars for each additional (1,000) gallons per day flow, or portion thereof.
- (e) Alternative subsurface sewage disposal systems permit application processing (excluding chamber and large diameter gravelless pipe systems), making inspections and other enforcement activities relative to the construction of alternative subsurface sewage disposal systems and expansion of systems because of additions resulting in added wastewater flow but not for repair of malfunctioning systems. Permits shall be granted or denied within forty-five (45) days of receipt of all necessary information. Three hundred (\$300.00) dollars up to (1,000) g.p.d. design flow plus one hundred fifty (\$150.00) dollars for each additional (1,000) gallons per day flow, or portion thereof.
- (f) Experimental subsurface sewage disposal systems permit application processing, making inspections and other enforcement activities relative to the construction of experimental subsurface sewage disposal systems and expansion of systems because of additions resulting in added wastewater flow but not for repair of malfunctioning systems. Permits shall be granted or denied within forty-five (45) days of receipt of all necessary information. Five hundred (\$500.00) dollars.
- (g) Subdivision Evaluation - Evaluations of lots within proposed subdivisions to determine and to specify limitations on their usability for subsurface sewage disposal systems. Sixty-five (\$65.00) dollars per lot.

RULEMAKING HEARINGS

- | | | |
|-----|--|---|
| (h) | Inspections of existing sewage systems. | Two hundred (200.00) dollars per inspection. |
| (i) | Installer and Pumper Permits – Enforcement activities relative to sewage system installers and septic tank pumpers. Permits shall be granted or denied within forty-five (45) days of the date of application. | Two hundred (\$200.00) dollars per permit for pumpers and installers of conventional, and large diameter gravelless pipe systems. An additional (\$100.00) dollars for each type of alternative System to be permitted for. |
| (j) | Sewage Surveys - Activities involved in the inspections and surveying of sewage systems. | Actual costs. |
| (k) | Water Samples - Collection of water samples for bacteriological laboratory analysis but does not include samples collected in enforcement activities. | |
| | (I) Mail Deliver | One hundred fifteen (\$115.00) dollars per sample. |
| | (II) Direct Deliver | Two hundred fifteen (\$215.00) dollars per sample. |
| (l) | Plans Review - Review of designs for large conventional or large alternative subsurface sewage disposal systems to the point of permit issuance. | Six hundred (\$600.00) dollars per proposed system. |
| (m) | Plat approval for individual lots. | Sixty-five (\$65.00) dollars per lot. |
| (n) | Domestic Septage Disposal Site Permit - Permit application processing, making inspections and other regulatory activity relative to domestic septage disposal sites. Permits shall be granted or denied within forty-five (45) days of receipt of all necessary information. | Four hundred (\$400.00) dollars. |
| (o) | Training - Non-state agencies and individuals | Calculated costs |
| (p) | Add Certificate of Verification | One hundred (\$100.00) dollars |

Authority: T.C.A. §§68-221-403, 4-5 et seq.

RULEMAKING HEARINGS

1200-1-6-.22 GENERAL PROVISIONS.

- (1) Applicability
 - (a) Rule 1200-1-6-.02 applies to subdivisions as defined in Rule 1200-1-6-.01. All subdivisions shall comply with applicable provisions of Rule 1200-1-6-.02.
 - (b) Rule 1200-1-6-.03 applies to subdivisions and individual lots. All subdivisions and individual lots shall comply with all applicable provisions of Rule 1200-1-6-.03.
 - (c) Rule 1200-1-6-.04 applies to percolation tests. Percolation tests may only be conducted as authorized in T.C.A. §§68-13-403(c). A percolation test is defined in Rule 1200-1-6-.01 and is not to be confused with soil analyses conducted by a soil consultant. All percolation tests shall comply with all provisions of Rule 1200-1-6-.04.
 - (d) Rule 1200-1-6-.05 applies to all construction permits whether an individual lot or a lot within a subdivision. All persons installing or having installed a subsurface sewage disposal system must comply with all provisions of Rule 1200-1-6-.05.
 - (e) Rule 1200-1-6-.06 applies to installation of conventional subsurface sewage disposal systems. All conventional disposal field installations shall comply with all provisions of Rule 1200-1-6-.06.
 - (f) Rule 1200-1-6-.07 applies to installation of all subsurface sewage disposal systems. All septic tanks shall comply with all provisions of Rule 1200-1-6-.07.
 - (g) Rule 1200-1-6-.08 applies to installation of all subsurface sewage disposal systems. All septic tanks shall comply with all provisions of Rule 1200-1-6-.08.
 - (h) Rule 1200-1-6-.09 applies to subsurface sewage disposal effluent treatment devices/systems. All effluent treatment devices/systems shall comply with applicable provisions of Rule 1200-1-6-.09.
 - (i) Rule 1200-1-6-.10 applies to subsurface sewage disposal systems. All septic tanks, dosing chambers and absorption fields shall be located in accordance with Rule 1200-1-6-.10.
 - (j) Rule 1200-1-6-.11 applies to subsurface sewage disposal systems requiring dosing. All dosing systems shall be designed and installed in accordance with Rule 1200-1-6-.11.
 - (k) Rule 1200-1-6-.12 applies to subsurface sewage disposal systems. It shall be the responsibility of the property owner and the Commissioner to adhere to Rule 1200-1-6-.12.
 - (l) Rule 1200-1-6-.13 applies to those subsurface sewage disposal systems that utilize grease traps. All grease traps shall be designed, constructed, operated and maintained in accordance with Rule 1200-1-6-.13.

RULEMAKING HEARINGS

- (m) Rule 1200-1-6-.14 applies to all alternative methods of subsurface sewage disposal. All alternative subsurface sewage disposal systems shall comply with the applicable provisions of Rule 1200-1-6-.14.
 - (n) Rule 1200-1-6-.15 applies to experimental methods of subsurface sewage disposal. All experimental methods of subsurface sewage disposal shall comply with Rule 1200-1-6-.15.
 - (o) Rule 1200-1-6-.16 applies to privies. All privies shall comply with applicable provisions of Rule 1200-1-6-.16.
 - (p) Rule 1200-1-6-.17 applies to all persons who apply for or who are approved soil consultants. Any person applying for or maintaining this approval shall comply with all applicable provisions of Rule 1200-1-6-.17.
 - (q) Rule 1200-1-6-.18 applies to all persons who apply for or who have a valid installer of subsurface sewage disposal systems permit. Any person applying for or maintaining this permit shall comply with all applicable provisions of Rule 1200-1-6-.18 at all times.
 - (r) Rule 1200-1-6-.19 applies to all persons who apply for or who have a valid septage removal permit. Any person applying for or maintaining this permit shall comply with all applicable provisions of Rule 1200-1-6-.19 at all times.
 - (s) Rule 1200-1-6-.20 applies to any person (as defined in Rule 1200-1-6-.01) who disposes of septage and any site which is used for septage disposal. Any person requesting approval to dispose of septage shall comply with all applicable provisions of Rule 1200-1-6-.20. Any site used for disposal of septage shall comply with all applicable provisions of Rule 1200-1-6-.20 at all times.
 - (t) Rule 1200-1-6-.21 applies to all services provided by the Division of Ground Water Protection. All applicants requesting a soil map, subsurface sewage disposal system permit, subdivision evaluation, inspection of an existing system, installer or pumper permit, sewage survey, water sample or plan review shall comply with all provisions of Rule 1200-1-6-.22.
 - (u) Rules 1200-1-6-.01 through 1200-1-6-.21 apply only to subsurface sewage disposal. They do not include surface discharge systems or holding tanks.
- (2) Severability. If any provision or application of any provision of these rules is held invalid, that invalidity shall not affect other provisions or applications of these rules.

Authority: T.C.A. §§68-13-403(a)(2) and Public Chapter 417.

RULEMAKING HEARINGS

APPENDIX I

Soil Series or Soil Phase	Soil Absorption Rate Min./In. (Average)	Foot Note
Abernathy	30	1
Adaton	>75	2
Adler	30	1
Agee	>75	4
Alcoa	45	
Allegheny	30	
Allen	45	
Alligator	>75	4
Almaville	>75	4
Almo	>75	
Alticrest	30	5
Altavista	30	2
Alva	15	1
Amagon	75	1
Apison	45	5
Arkabutla	45	4
Armour	30	
Armuchee	>75	5
Arrington	30	1
Ashe	15	3
Askew	45	1
Ashwood	>75	3
Atkins	30	4
Augusta	>75	2
Balfour	30	
Barbourville	15	1
Barfield	2	
Barger	2	
Fragipan>20 inches	75	
Fragipan<20 inches	>75	
Bays	>75	3
Baxter (Cherty)	60	
Beason	>75	2
Bedford		
more than 24 inches to fragipan	75	
less than 24 inches to fragipan	>75	
Beechy	30	4
Bellamy	2	
Fragipan>20 inches	75	6
Fragipan<20 inches	>75	
Bewleyville	45	
Bibb	15	4
Biffle	45	5
Biltmore	<10	1

RULEMAKING HEARINGS

APPENDIX I (continued)

Soil Series or Soil Phase	Soil Absorption Rate Min./In. (Average)	Foot Note
Birds	30	4
Bland	>75	3
Bloomington	>75	4
Bodine (Cherty)	30	
Bolton	45	
Bonair	30	4
Bonn	>75	2
Bosket	30	1
Boswell	>75	
Bouldin	10	
Bowdre	30	4
Bradyville		
more than 20 inches to clay	75	
less than 20 inches to clay	>75	
Brandon	30	
Brantley	>75	
Brasstown	45	
Braxton		
more than 24 inches to clay	75	
less than 24 inches to clay	>75	
Brevard	30	
Briensburg	30	1
Britton	>75	
Brookshire	15	
Bruno	<10	1
Bryson		
more than 24 inches to fragipan	75	2
less than 24 inches to fragipan	>75	2
Buncombe	<10	1
Burgin	>75	2
Burton	30	3
Busselton		
Fragipan>20 inches	75	6
Fragipan<20 inches	>75	
Byler		
more than 24 inches to fragipan	5	2
less than 24 inches to fragipan	>75	2
Calhoun	>75	2
Calloway	>75	2
Calvin	>75	3
Camp	30	1
Cannon	15	1
Capshaw	>75	2

RULEMAKING HEARINGS

APPENDIX I (continued)

Soil Series or Soil Phase	Soil Absorption Rate Min./In. (Average)	Foot Note
Captina		
more than 24 inches to fragipan	75	2
less than 24 inches to fragipan	>75	2
Carbo	>75	3
Cataska	>75	
Caylor	60	
Center	75	2
Chagrin	30	1
Chenneby	45	2
Chewacla	30	4
Chickasaw	>75	
Christian	>75	
Citico	45	
Claiborne	45	
Clarksville (Cherty)	30	
Clarkrange		
more than 24 inches to fragipan	75	2
less than 24 inches to fragipan	>75	2
Clifton	45	
Cloudland		
more than 24 inches to fragipan	75	2
less than 24 inches to fragipan	> 75	2
Cobstone	15	1
Coghill	>7	5
Coile	>75	5
Colbert	>75	
Collegedale	>75	
Collins	30	1
Commerce	60	4
Conasauga	>75	2
Conagree	15	1
Convent	45	4
Cookeville	60	
Corryton	>75	
Cotaco	30	1
Craggey	>75	
Craigsville	15	1
Crevassee	<101	
Crider	30	
Crossville	303	
Culleoka	30	5
Cumberland	45	
Curtistown	30	
Cuthbert	>75	3
Cynthiana	>75	3

RULEMAKING HEARINGS

APPENDIX I (continued)

Soil Series or Soil Phase	Soil Absorption Rate Min./In. (Average)	Foot Note
Dandridge	>75	3
Deanburg	30	
Decatur	45	
DeKalb	15	5
Dekoven	>75	4
Delanco	30	2
Dellrose (Cherty)	30	
Dewey	60	
Dexter	30	
Dickson		
more than 24 inches to fragipan	75	2
less than 24 inches to fragipan	>75	2
Dilton	75	2
Ditney	30	5
Donerail	>75	
Dowelltown	>75	2
Dubbs	45	1
Dulac		
more than 24 inches to fragipan	75	2
less than 24 inches to fragipan	>75	
Dundee	60	4
Dunmore		
more than 24 inches to clay	60	
less than 24 inches to clay	75	
Dunning	>75	2
Dyer	45	4
Eagleville	>75	3
Ealy	15	1
Egam	>75	1
Elk	45	
Elkins	45	4
Elliber	30	
Ellisville	30	1
Emory	30	1
Enders	>75	
Ennis	30	1
Enville	45	4
Etowah	30	
Eustis	<10	
Eupora	30	4
Evard	45	
Fairmount	>75	3
Falaya	45	4
Falkner	>75	
Fannin	30	5

RULEMAKING HEARINGS

APPENDIX I (continued)

Soil Series or Soil Phase	Soil Absorption Rate Min./In. (Average)	Foot Note
Farragut		
more than 36 inches to shale material	75	
less than 36 inches to shale material	>75	
Fletcher	45	
Forestdale	>75	4
Fountain	>75	2
Frankstown (Cherty)	45	
Freeland		
more than 24 inches to fragipan	75	2
less than 24 inches to fragipan	>75	2
Fullerton (Cherty)	45	
Fullerton	60	
Gilpin	>75	3
Gladdice	>75	3
Gladeville	>75	3
Godwin	>75	4
Greendale (Cherty)	30	1
Grenada		
more than 24 inches to fragipan	75	2
less than 24 inches to fragipan	>75	2
Groseclose	>75	
Guin	15	
Gumdale	>75	2
Guthrie	>75	4
Guyton	>75	2
With subsurface drains	75	
Hagerstown	60	
Hamblen	30	1
Hampshire	>75	
Hanceville	45	
Harpeth	30	
Hartsells	30	5
Hatchie	>75	2
Hawthorne	45	5
Hayesville	45	
Hayter	45	
Hector	>75	3
Hendon		2
Fragipan>20 inches	75	6
Fragipan<20 inches	>75	
Henry	>75	2
Hermitage	30	
Hicks	45	
Hillwood	45	
Hiwassee	45	

RULEMAKING HEARINGS

APPENDIX I

Soil Series or Soil Phase	Note	Soil Absorption Rate Min./In. (Average)	Foot
Hollywood		>75	2
Holston		45	
Humphreys		30	
Huntington		30	1
Hymon		30	1
Iberia		>75	4
Ina		45	4
Inman		>75	3
Iron City		60	
Iuka		30	1
Jeffrey		30	3
Jefferson		30	
Jefferson			
Stoney		15	
Cobbly		15	
Gravelly		15	
Johnsburg		>75	2
Junaluska		45	5
Keener		45	
Landisburg		>75	2
Lanton		>75	1
Lawrence		>75	2
Lax			
more than 24 inches to fragipan		75	
less than 24 inches to fragipan		>75	
Leadvale		>75	2
Lee		30	4
Leesburg		30	
Lehew		30	5
Lewistown		>75	
Lexington		30	
Lickdale		60	4
Lily		30	5
Lindell		30	1
Lindside		30	1
Linker		30	5
Litz		>75	3
Lintonia		45	
Lobdell		30	1
Lobelville		30	1
Lomond		45	
Lonewood		60	
Lonon		45	
Loring			
more than 24 inches to fragipan		75	

RULEMAKING HEARINGS

APPENDIX I

Soil Series or Soil Phase	Note	Soil Absorption Rate Min./In. (Average)	Foot
	less than 24 inches to fragipan	>75	
Lost Cove		30	
Lucy		30	
Luverne		>75	
Lynnville		45	4
Magnolia		>75	
Manse		30	
Mantachie		45	4
Marsh		45	3
Masada		30	
Matney		30	3
Maury		45	
Maymead		30	
McCamy		30	3
Melvin		45	4
Memphis		45	
Mercer			
	more than 24 inches to fragipan	75	2
	less than 24 inches to fragipan	>75	2
Mhoon		60	4
Mimosa		>75	
Minter		>75	4
Minvale		45	
Minvale (Cherty)		30	
Morganfield		30	1
Monongahela			
	more than 24 inches to fragipan	75	2
	less than 24 inches to fragipan	>75	2
Monteagle		60	3
Montevallo		>75	3
Morehead		>75	4
	With drainage	75	
Mountview		45	
Muskingum		60	3
Mullins		>75	4
Muse		>75	
Natchez		60	
Needmore		>75	5
Nella		15	
Nesbitt		75	
Neubert		15	1
Newark		30	4
Nixa			
	more than 24 inches to fragipan	75	
	less than 24 inches to fragipan	>75	

RULEMAKING HEARINGS

APPENDIX I

Soil Series or Soil Phase	Note	Soil Absorption Rate Min./In. (Average)	Foot
Noah		75	
Nolichucky		30	
Nolin		30	1
Norene		>75	4
Northcove		30	
Nugent		<10	1
Oaklimeter		30	1
Ocana		15	1
Ochlochkonee		30	1
Oktibbeha		>75	
Oliver		>75	4
Ooltewah		30	1
Opeduon		>75	3
Openlake		>75	1
Orrville		30	4
Pace		75	2
Paden			
more than 24 inches to fragipan		75	2
less than 24 inches to fragipan		>75	2
Pailo		60	
Paraloma			
more than 24 inches to fragipan		75	2
less than 24 inches to fragipan		>75	2
Pembroke		45	
Perkinsville		45	
Petros		>75	3
Pettyjon		45	1
Philo		30	1
Pickaway			
more than 24 inches to fragipan		75	2
less than 24 inches to fragipan		>75	2
Pickwick		60	
Pikeville		45	
Platt		30	
Pope		30	1
Porters		30	5
Potomac		45	1
Prentiss			
more than 24 inches to fragipan		75	2
less than 24 inches to fragipan		>75	2
Providence			
more than 24 inches to fragipan		75	2
less than 24 inches to fragipan		>75	2
Pruitton		45	1
Pottsville		>75	3

RULEMAKING HEARINGS

APPENDIX I

Soil Series or Soil Phase	Note	Soil Absorption Rate Min./In. (Average)	Foot
Purdy		>75	4
Ramsey		>75	3
Ranger		45	5
Red Hills		45	5
Reelfoot		60	4
Renox		45	
Richland			
more than 24 inches to fragipan		75	2
less than 24 inches to fragipan		>75	2
Riverby		15	1
Roane		>75	4
Roanoke		>75	2
Robertsville		>75	4
Robinsonville		15	1
Roellen		>75	2
Rosebloom		45	4
Routon		>75	2
Russellville			
more than 24 inches to fragipan		75	2
less than 24 inches to fragipan		>75	2
Ruston		30	
Saffell		30	
Safford		>75	
Sango			
more than 24 inches to fragipan		75	2
less than 24 inches to fragipan		>75	2
Savannah			
more than 24 inches to fragipan		75	2
less than 24 inches to fragipan		>75	2
Sees		>75	
Sensabaugh		30	1
Sentown		60	
Sequatchie		30	1
Sequoia		>75	
Sewanee		30	1
Shack			2
Fragipan>20 inches		75	6
Fragipan<20 inches		>75	
Shady		45	
Shannon		30	1
Shelocta		45	
Sharkey		>75	4
Shouns		60	
Shubuta		75	

RULEMAKING HEARINGS

APPENDIX I

Soil Series or Soil Phase	Note	Soil Absorption Rate Min./In. (Average)	Foot
Silerton			
	more than 24 inches to clay	75	
	less than 24 inches to clay	>75	
Skidmore		30	1
Smithdale		30	
Soco		45	5
Solway		>75	3
Spivey		15	
Staser		30	1
State		30	1
Statler		30	1
Steadman		>75	4
	With drainage	75	
Steekee		>75	3
Steens		75	2
Stemley			
	more than 24 inches to fragipan	75	2
	less than 24 inches to fragipan	>75	2
Stiversville		30	
Suches			1
	Well drained	45	
	Moderately well drained with Subsurface drained	45	
Sugargrove		45	5
Sulphura		>75	3
Sullivan		30	1
Sumter		>75	
Sunlight		>75	3
Susquehanna		>75	
Swafford			
	more than 24 inches to fragipan	75	2
	less than 24 inches to fragipan	>75	2
Swaim		>75	
Sweatman		>75	
	Depth to clay>30 inches	60	
	Depth to clay 24 to 30 inches	75	
	Depth to clay<24 inches	>75	
Sylco		>75	5
Taft		>75	2
Talbott		>75	3
Talladega		>75	3
Tallant		60	3
Tarklin			
	more than 24 inches to fragipan	75	2
	less than 24 inches to fragipan	>75	2

RULEMAKING HEARINGS

APPENDIX I

Soil Series or Soil Phase	Note	Soil Absorption Rate Min./In. (Average)	Foot
Tasso			
more than 24 inches to fragipan		75	
less than 24 inches to fragipan		>75	
Tate		30	
Teas		>75	3
Tellico		45	
Tichnor		>75	4
Tickfaw		>75	4
Tigrett		30	1
Tilsit			
more than 24 inches to fragipan		75	2
less than 24 inches to fragipan		>75	2
Tioga		10	1
Tippah			
more than 24 inches to clay		75	
less than 24 inches to clay		>75	
Tiptonville		45	1
Toccoa		>75	1
With drainage		30	
Tooterville		>75	4
Townley		>75	5
Trace		45	1
Transylvania		15	1
Trappist		>75	5
Tsali		>75	5
Tunica		>75	4
Tupelo		>75	2
Tuscumbia		>75	4
Tusquitee		30	
Tyler		>75	2
Una		>75	4
Unaka		30	5
Unicoi		>75	3
Upshur		>75	
Urbo		>75	
Vacherie		>75	4
Vaiden		>75	2
Vicksburg		30	1
Wakeland		45	4
Wallen		45	5
Watauga		30	5
Waverly		45	4
Waynesboro		60	

RULEMAKING HEARINGS

APPENDIX I

Soil Series or Soil Phase	Note	Soil Absorption Rate Min./In. (Average)	Foot
Waynesboro			
Gravelly		30	
Weaver		30	1
Wehadkee		45	4
Welchland		15	1
Wellston		75	
Weon		>75	
Whitesburg		45	1
Whitwell		45	2
Wilcox		>75	
Woodmont		>75	2
Wolftever		>75	2
Woolper		>75	
Worthen		30	
more than 24 inches to fragipan		75	2
less than 24 inches to fragipan		>75	2
Zenith		45	5

FOOTNOTES

1. Flooding or standing water during brief periods of high rainfall make many areas of these soils unsuitable even though the absorption rate is favorable. Areas protected from flooding or otherwise not subject to flooding may be suitable. These are dominantly well drained and moderately well drained soils along rivers and streams.
2. A seasonally high watertable due to position in landscape and/or soil properties make most areas of these soils unsuitable.
3. Depth to bedrock is generally not sufficient to accommodate a septic tank system. There are some spots of these soils with adequate depths.
4. Flooding and/or a seasonally high watertable make these soils unsuitable sites for subsurface sewage disposal systems. Areas protected from flooding and/or artificially drained may be suitable.
5. Depth to bedrock is generally sufficient to accommodate a filter field system. There are some spots of these soils with inadequate depths.

Depths equal to or less than 24 inches and equal to or greater than 20 inches shall be used on extra high intensity soil maps only.

RULEMAKING HEARINGS

APPENDIX II

SOIL ABSORPTION/PERCOLATION RATES AND CORRESPONDING
 ABSORPTION AREA REQUIREMENTS

ABSORPTION/PERCOLATION RATES	ABSORPTION AREA (A S TRENCH BOTTOM RATES	
	IN MINUTES PER INCH	AREA) SQ. FT./BEDROOM
	SQ. FT./GAL.	
10	1.2	165
15	1.4	190
30	2.0	250
45	2.5	300
60	2.9	330
75	3.2	370
80	3.3	380
85	3.4	390
90	3.5	400
95	3.6	415
100	3.7	430
105	3.8	445

NOTE: Round percolation rates to next highest increment of five (5).

NOTE: Trenches of two (2) to three (3) feet in width are preferred. For trenches greater than three (3) feet in width, increase absorption area by the following factors:

<u>Trench Width</u>	<u>Factor</u>
4	1.33
6	1.50
8	1.60

- EXAMPLES:
1. The soil absorption rate is fifteen (15) minutes per inch. A factory with a daily flow of three thousand (3,000) gallons is to be located on this site. Three thousand (3,000) gal. x one point four (1.4) sq. ft./gal. = four thousand two hundred (4,200) sq. ft. If a two (2) ft. width trench is used, four thousand two hundred (4,200) sq. ft. ÷ two (2) = two thousand one hundred (2,100) linear feet needed.
 2. The soil absorption rate is thirty (30) minutes per inch. A four (4) bedroom house is to be constructed. Two hundred and fifty (250) sq. ft./bedroom x four (4) bedrooms = one thousand (1,000) sq. ft. If a three (3) ft. width trench is used, one thousand (1,000) square ft. ÷ three (3) = three hundred and thirty-three point three (333.3) linear ft. needed.

NOTE: Flow rates for non-residential establishments will be based on the memo from Kent D. Taylor to the Division of Ground Water Protection Field Office Managers dated July 8, 1993, regarding expected sewage flow from non-residential establishments.

RULEMAKING HEARINGS

APPENDIX III

FRICITION LOSS, IN FEET, THROUGH 100 FEET OF SCHEDULE 40 PVC PIPE

----- Pipe Diameter (in.) -----

Flow (GPM)	1"	1 1/4"	1 1/2"	2"	3"	4"	6"
1	.09						
2	.32	.09					
3	.68	.18	.08				
4	1.17	.31	.14				
5	1.76	.46	.22	.06			
6	2.47	.65	.31	.09			
7	3.28	.86	.41	.12			
8	4.20	1.10	.52	.15			
9	5.22	1.37	.65	.19			
10	6.35	1.67	.79	.23			
11	7.57	1.99	.94	.28			
12		2.34	1.10	.33			
13		2.71	1.28	.38			
14		3.11	1.47	.43	.06		
15		3.54	1.67	.49	.07		
16		3.98	1.88	.56	.08		
17		4.46	2.10	.62	.09		
18		4.95	2.34	.69	.10		
19		5.47	2.58	.77	.11		
20		6.02	2.84	.84	.12		
25			4.29	1.27	.19		
30			6.02	1.78	.25	.07	
35				2.37	.35	.09	
40				3.03	.44	.12	
45				3.77	.55	.15	
50				4.58	.67	.18	
60				6.42	.94	.25	
70					1.25	.33	
80					1.60	.43	.06
90					1.99	.53	.07
100					2.41	.64	.09
125					3.65	.97	.13

RULEMAKING HEARINGS

APPENDIX III (continued)

FRICTION LOSS, IN FEET, THROUGH 100 FEET OF SCHEDULE 40 PVC PIPE

Flow (GPM)	----- Pipe Diameter (in.) -----						
	1"	1 1/4"	1 1/2"	2"	3"	4"	6"
150					6.11	1.36	.19
175					6.80	1.81	.25
200						2.32	.32
225						2.88	.39
250						3.50	.48
275						4.18	.57
300						4.91	.67
325						5.69	.77
350						6.53	.89
375						7.41	1.01
400							1.14
425							1.27
450							1.41
475							1.56
500							1.72
550							2.05
600							2.40
650							2.79
700							3.20
750							3.63
800							4.09
850							4.58
900							5.09
950							5.63

Notes: 160 PSI pipe assumed to be SDR 26.
 Computed by the Hazen Williams Formula, assuming C = 140:

$$h_f = \frac{0.00113LQ^{1.85}}{D^{4.87}}$$

- h_f = head loss (feet)
- L = pipe length
- Q = flow (GPM)
- D = pipe inside diameter (inches)

The notice of rulemaking set out herein was properly filed in the Department of State on the 30th day of May, 2005. (05-28)

RULEMAKING HEARINGS

TENNESSEE DEPARTMENT OF FINANCE AND ADMINISTRATION - 0620 BUREAU OF TENNCARE

There will be a hearing before the Commissioner to consider the promulgation of amendments of rules pursuant to Tennessee Code Annotated, 71-5-105 and 71-5-109. The hearing will be conducted in the manner prescribed by the Uniform Administrative Procedures Act, Tennessee Code Annotated, Section 4-5-204 and will take place in the Multi Media Room, 3rd Floor, W.R. Snodgrass Tennessee Tower, 312 8th Avenue North, Nashville, Tennessee 37243, at 9:00 a.m. C.D.T. on the 18th day July 2005.

Any individuals with disabilities who wish to participate in these proceedings (to review these filings) should contact the Department of Finance and Administration, Bureau of TennCare, to discuss any auxiliary aids or services needed to facilitate such participation. Such initial contact may be made no less than ten (10) days prior to the scheduled meeting date (the date the party intends to review such filings) to allow time for the Bureau of TennCare to determine how it may reasonably provide such aid or service. Initial contact may be made with the Bureau of TennCare's ADA Coordinator by mail at the Bureau of TennCare, 729 Church Street, Nashville, Tennessee 37247-6501 or by telephone at (615) 741-0155 or 1-800-342-3145.

For a copy of this notice of rulemaking hearing, contact George Woods at the Bureau of TennCare, 729 Church Street, Nashville, Tennessee 37247-6501 or call (615) 741-0145.

SUBSTANCE OF PROPOSED RULE

Rule 1200-13-13-.12 Other Appeals By TennCare Applicants and Enrollees is amended by deleting paragraph (1) in its entirety and by substituting instead the following new language so that as amended paragraph (1) shall read as follows:

- (1) Appeal Rights of TennCare Standard or TennCare Medicaid Applicants or Enrollees.
 - (a) TennCare Standard and TennCare Medicaid applicants or enrollees will be given the opportunity to have an administrative hearing before a Hearing Officer of an Administrative Law Judge, as determined by the Department of Human Services, regarding valid factual disputes concerning denial of his/her application, cost sharing disputes, limitation, reduction or termination of coverage, failure to act upon a request or application within required timeframes, and disputes regarding disenrollment from TennCare Standard or TennCare Medicaid. A valid factual dispute in a dispute that, if resolved in favor of the appellant, would prevent the state from taking the adverse action that is the subject of the appeal.
 - (b) Such appeals will be conducted by the Department of Human Services for TennCare Medicaid and TennCare Standard applicants/enrollees under the Department of Human Services' administrative procedures rules, in accordance with subchapter 1200-13-14-.12(1), and in accordance with any other applicable rules, laws or court orders governing those programs.

Authority: T.C.A. §§4-5-202, 4-5-203, 71-5-105, 71-5-109, Executive Order No. 23.

The notice of rulemaking set out herein was properly filed in the Department of State on the 31st day of May, 2005. (05-42)

RULEMAKING HEARINGS

TENNESSEE DEPARTMENT OF FINANCE AND ADMINISTRATION - 0620 Bureau of TennCare

There will be a hearing before the Commissioner to consider the promulgation of amendments of rules pursuant to Tennessee Code Annotated, 71-5-105 and 71-5-109. The hearing will be conducted in the manner prescribed by the Uniform Administrative Procedures Act, Tennessee Code Annotated, Section 4-5-204 and will take place in the Multi Media Room, 3rd Floor, W.R. Snodgrass Tennessee Tower, 312 8th Avenue North, Nashville, Tennessee 37243, at 9:00 a.m. C.D.T. on the 18th day July 2005.

Any individuals with disabilities who wish to participate in these proceedings (to review these filings) should contact the Department of Finance and Administration, Bureau of TennCare, to discuss any auxiliary aids or services needed to facilitate such participation. Such initial contact may be made no less than ten (10) days prior to the scheduled meeting date (the date the party intends to review such filings) to allow time for the Bureau of TennCare to determine how it may reasonably provide such aid or service. Initial contact may be made with the Bureau of TennCare's ADA Coordinator by mail at the Bureau of TennCare, 729 Church Street, Nashville, Tennessee 37247-6501 or by telephone at (615) 741-0155 or 1-800-342-3145.

For a copy of this notice of rulemaking hearing, contact George Woods at the Bureau of TennCare, 729 Church Street, Nashville, Tennessee 37247-6501 or call (615) 741-0145.

SUBSTANCE OF PROPOSED RULE

Rule 1200-13-14-.02 - Eligibility is amended by adding paragraph (9) - Disenrollment Related to TennCare Standard Eligibility Reforms

Due to the implementation of TennCare Standard eligibility-related reforms which will eliminate the TennCare Standard eligibility categories for adults age 19 and older, TennCare Standard enrollees must have their eligibility redetermined to see if they qualify for any open Medicaid eligibility categories. The new rule lays out the procedures to be followed by DHS for this redetermination and the relevant timelines. The DHS review of eligibility will follow the requirements set forth by CMS in the Special Terms and Conditions of the TennCare demonstration project.

At least thirty (30) days before an enrollee is scheduled to be disenrolled, DHS will send to each enrollee that the State has been unable to determine eligible for an open Medicaid eligibility category based on ex parte review, a form that s/he must return to DHS. The form will include certain information so that DHS can determine if the enrollee qualifies for an open Medicaid category. Enrollees with disabilities or with limited English proficiency will have the opportunity to seek additional assistance in responding to the Request for Information. Enrollees will have thirty (30) days to provide the State with all of the necessary information for DHS to determine whether the individual is eligible for an open Medicaid category, but may request an extension based on good cause in limited special circumstances such as serious illness or death of an immediate family member. DHS shall have discretion in evaluating such requests for good cause extension on a case-by-case basis, and DHS' decisions on granting good cause exceptions will not themselves be fair hearable.

If the information received by DHS is incomplete, the State will send the enrollee a Verification Request notice. S/he will then have ten (10) days (inclusive of mail time) to send in the additional required information. If enrollees submit all of the remaining requested information during this 10-day time period, enrollees will retain coverage (subject to applicable changes in the TennCare Standard benefit package) until DHS determines that the individual does not qualify for open categories of TennCare Medicaid (and proper disenrollment and appeal processes have been completed).

RULEMAKING HEARINGS

DHS will use all of the information provided by the enrollee to determine if s/he meets eligibility requirements for an open Medicaid category. If the form is submitted within the 30-day time period following the Request for Information, enrollees will retain eligibility for TennCare Standard while DHS is completing its determination (subject to applicable changes in the TennCare Standard benefit package).

If the enrollee qualifies for an open Medicaid category, DHS will notify the enrollee and will enroll him/her into that category. If the enrollee does not qualify for an open Medicaid category or fails to respond timely to DHS' request for information, TennCare will send the enrollee a 20-day advance notice of termination. The enrollee will then have forty (40) days inclusive of mail time to appeal factual disputes related to the action of disenrollment. If the enrollee appeals prior to the date of action, the enrollee will retain coverage (subject to applicable changes in the TennCare Standard benefit package) pending resolutions of the appeal. The State reserves its right to recover from the enrollee the cost of services provided during the hearing process. The State will Grant fair hearings only for those enrollees raising valid factual disputes related to the action of disenrollment.

Authority: *T.C.A. 4-5-202, 71-5-105, 71-5-109, Executive Order No. 23.*

The notice of rulemaking set out herein was properly filed in the Department of State on the 31st day of May, 2005. (05-43)

RULEMAKING HEARINGS

TENNESSEE DEPARTMENT OF FINANCE AND ADMINISTRATION - 0620 BUREAU OF TENNCARE

There will be a hearing before the Commissioner to consider the promulgation of amendments of rules pursuant to Tennessee Code Annotated, 71-5-105 and 71-5-109. The hearing will be conducted in the manner prescribed by the Uniform Administrative Procedures Act, Tennessee Code Annotated, Section 4-5-204 and will take place in the Multi Media Room, 3rd Floor, W.R. Snodgrass Tennessee Tower, 312 8th Avenue North, Nashville, Tennessee 37243 at 9:00 a.m. C.D.T. on the 18th day July 2005.

Any individuals with disabilities who wish to participate in these proceedings (to review these filings) should contact the Department of Finance and Administration, Bureau of TennCare, to discuss any auxiliary aids or services needed to facilitate such participation. Such initial contact may be made no less than ten (10) days prior to the scheduled meeting date (the date the party intends to review such filings) to allow time for the Bureau of TennCare to determine how it may reasonably provide such aid or service. Initial contact may be made with the Bureau of TennCare's ADA Coordinator by mail at the Bureau of TennCare, 729 Church Street, Nashville, Tennessee 37247-6501 or by telephone at (615) 741-0155 or 1-800-342-3145.

For a copy of this notice of rulemaking hearing, contact George Woods at the Bureau of TennCare, 729 Church Street, Nashville, Tennessee 37247-6501 or call (615) 741-0145.

SUBSTANCE OF PROPOSED RULE

Rule 1200-13-14-.12 Other Appeals By TennCare Applicants and Enrollees is amended by deleting paragraph (1)(a) in its entirety and by substituting instead the following new language so that as amended paragraph (1)(a) shall read as follows:

- (1) Appeal Rights of TennCare Standard or TennCare Medicaid Applicants or Enrollees.
 - (a) Appeal Time; Continuation of Services.
 1. TennCare Standard and TennCare Medicaid Appeals.
 - (i) TennCare Standard and TennCare Medicaid applicants or enrollees will be given the opportunity to have an administrative hearing before a Hearing Officer or an Administrative Law Judge, as determined by the Department of Human Services, regarding valid factual disputes concerning denial of his/her application, cost sharing disputes, limitation, reduction or termination of coverage, failure to act upon a request or application within required timeframes, and disputes regarding disenrollment from TennCare Standard or TennCare Medicaid. A valid factual dispute is a dispute that, if resolve in favor of the appellant, would prevent the state from taking the adverse action that is the subject of the appeal.
 - (ii) Requests for appeals must be made within forty (40) calendar days, including mail time, of the date of the notice to the applicant/enrollee regarding the intended action, notwithstanding the provisions of Chapter 1240-5-3-.03 relating to the ninety (90) day timeframe for filing of an appeal of an intended action for TennCare Medicaid applicants/enrollees, and any provisions regarding the time within which to file an appeal in order to maintain coverage while the appeal is determined.

RULEMAKING HEARINGS

- (iii) If the enrollee whose TennCare Standard or TennCare Medicaid coverage is being reduced or terminated or whose cost sharing is in dispute wants his/her coverage or cost sharing obligation to remain unchanged while the appeal is being determined, s/he must submit his/her appeal within ten (10) days of the date of the notice sent to the enrollee regarding the intended action, or prior to the effective date of the intended action, whichever is later.

The notice of rulemaking set out herein was properly filed in the Department of State on the 31st day of May, 2005. (05-44)

RULEMAKING HEARINGS

DEPARTMENT OF HEALTH - 1200 BOARD FOR LICENSING HEALTH CARE FACILITIES DIVISION OF HEALTH CARE FACILITIES

There will be a hearing before the Board for Licensing Health Care Facilities to consider the promulgation of amendment of rules pursuant to T.C.A. §§ 4-5-202, 4-5-204, 68-11-202 and 68-11-209. The hearing will be conducted in the manner prescribed by the Uniform Administrative Procedures Act, Tennessee Code Annotated, Section 4-5-204 and will take place in the Tennessee Room on the Ground floor of the Cordell Hull Building located at 425 Fifth Avenue North, Nashville, TN at 9:00 a.m. (CDST) on the 18th day of July, 2005.

Any individuals with disabilities who wish to participate in these proceedings (review these filings) should contact the Department of Health, Division of Health Care Facilities to discuss any auxiliary aids or services needed to facilitate such participation or review. Such initial contact may be made no less than ten (10) days prior to the scheduled meeting date (the date such party intends to review such filings), to allow time for the Division to determine how it may reasonably provide such aid or service. Initial contact may be made with the ADA Coordinator at the Division of Health Care Facilities, First Floor, Cordell Hull Building, 425 Fifth Avenue North, Nashville, TN 37247-0508, (615) 741-7598.

For a copy of the entire text of this notice of rulemaking hearing visit the Department of Health's web page on the Internet at www.state.tn.us/health and click on "rulemaking hearings" or contact: Steve Goodwin, Health Facility Survey Manager, Division of Health Care Facilities, 425 Fifth Avenue North, First Floor, Cordell Hull Building, Nashville, TN 37247-0508, (615) 741-7598.

SUBSTANCE OF PROPOSED RULES

CHAPTER 1200-8-1 STANDARDS FOR HOSPITALS

AMENDMENTS

Rule 1200-8-1-.01, Definitions, is amended by deleting paragraph (17) in its entirety and substituting instead the following language, so that as amended, the new paragraph (17) shall read:

- (17) Critical Access Hospital. A hospital located in a rural area, certified by the Department as being a necessary provider of health care services to residents of the area, which makes available twenty-four (24) hour emergency care; is a designated provider in a rural health network; provides not more than twenty-five (25) acute care inpatient beds for providing inpatient care not to exceed an annual average of ninety-six (96) hours, and has a quality assessment and performance improvement program and procedures for utilization review. If swing-bed approval has been granted, all twenty-five (25) beds can be used interchangeably for acute or Skilled Nursing Facility (SNF/swing-bed) level of care services. For the purposes of determining eligibility of a hospital to reclassify as a critical access hospital, "rural" is defined as any Tennessee county outside the four metropolitan areas of Davidson, Hamilton, Knox, and Shelby counties.

Authority: T.C.A. §§4-5-202, 4-5-204, 68-11-202, 68-11-204, 68-11-207, 68-11-209, 68-11-210, 68-11-211, 68-11-213, and 68-11-255.

The notice of rulemaking set out herein was properly filed in the Department of State on the 4th day of May, 2005. (05-04)

RULEMAKING HEARINGS

THE TENNESSEE DEPARTMENT OF HUMAN SERVICES - 1240 DIVISION OF ADULT AND FAMILY SERVICES

There will be a hearing before the Tennessee Department of Human Services to consider the promulgation of amendments to rules pursuant to Tennessee Code Annotated §§ 4-5-201 et seq. and 71-1-105(12). The hearing will be conducted in the manner prescribed by the Uniform Administrative Procedures Act, Tennessee Code Annotated, § 4-5-204 and will take place in the 2nd Floor, BoardRoom, Citizens Plaza Building, 400 Deaderick Street, Nashville, Tennessee at 1:30p.m. CDT on, Tuesday, July 19, 2005.

Any individuals with disabilities who wish to participate in these proceedings (to review these filings) should contact the Department of Human Services to discuss any auxiliary aids or services needed to facilitate such participation. Such initial contact may be made no less than ten (10) days prior to the scheduled meeting date (the date the party intends to review such filings), to allow time for the Department of Human Services to determine how it may reasonably provide such aid or service. Initial contact may be made with the Department of Human Services' ADA Coordinator, Fran McKinney, Citizens Plaza Building, 400 Deaderick Street, 3rd Floor, Nashville, Tennessee 37248, telephone number (615) 313-5563 (TTY)-(800) 270-1349.

For a copy the proposed rule contact: Phyllis Simpson, Assistant General Counsel, Department of Human Services, Citizens Plaza Building, 400 Deaderick Street, 15th Floor, Nashville, TN 37248-0006, telephone number (615) 313-4731.

SUBSTANCE OF PROPOSED RULES OF THE TENNESSEE DEPARTMENT OF HUMAN SERVICES ADULT AND FAMILY SERVICES DIVISION

CHAPTER 1240-1-50 FINANCIAL ELIGIBILITY REQUIREMENTS FAMILIES FIRST PROGRAM

AMENDMENTS

Rule 1240-1-50-.20 Standard Of Need/Income, is amended by deleting the Rule in its entirety and by substituting instead the following language so that, as amended, the rule shall read:

1240-1-50-.20 Standard Of Need/Income. The following table shows the maximum income level, consolidated standard of need, and the possible standard payment amounts and differential grant payment amounts (maximum payment per assistance group size) to be used in the Families First program to determine eligibility and amount of payment.

- (1) Families First Cash Assistance Standards
 - (a) Consolidated Need Standard (CNS). The Department has developed a consolidated standard of need based on size of the assistance group (AG), which indicates the amount of income the assistance group would need to meet subsistence living costs according to allowances set by the state for items including food, clothing, shelter and utilities, transportation, medical care, personal incidentals, and school supplies. The CNS is used as the basis for

RULEMAKING HEARINGS

determining the gross income standard (GIS), the standard payment amount (SPA), and the Differential Grant Payment Amount (DGPA).

- (b) Gross Income Standard (GIS). This standard is set at One Hundred Eighty-Five Percent (185%) of the consolidated need standard. If the gross countable income of an assistance group exceeds this standard, the Assistance Group (AG) is not eligible for Families First.

Standard Payment Amount (SPA). Tennessee does not meet One Hundred Percent (100%) of need as defined by the consolidated need standard. Rather, a maximum payment by family size, dependent on available State and Federal funds is paid, except in the instances specified in 1240-1-50-.20(e).

- (d) Differential Grant Payment Amount (DGPA). A Families First Assistance Group which meets any one of the criteria for exemption from Time Limited Assistance as specified in 1240-1-51-.01(4)(a) through (d), will be eligible for a grant based on the Differential Grant Payment Amount (DGPA), which is a maximum payment by family size, dependent on funds available, except in the instances specified in subparagraph (e) below.

- (e) Family Benefit Cap

1. No additional benefits will be issued due to the birth of a child when the birth occurs more than ten (10) calendar months after the later of:
 - (i) the date of application for Families First, or
 - (ii) the date of implementation of the Families First program (September 1, 1996), as provided by T.C.A. § 71-3-151, unless:
 - (I) the child was conceived as the result of verified rape or incest;
 - (II) the child is the firstborn (including all children in the case of a multiple birth) of a minor included in the Families First grant who becomes a first-time minor parent;
 - (III) the child does not reside with his/her parent;
 - (IV) the child was conceived in a month the AG was not receiving Families First; or
 - (V) the child was already born prior to the later of the date of application for Families First or the date of implementation of Families First, and the child has entered or returned to the home.
2. The additional child will be included in the need standard for the purpose of determining Families First eligibility. The income of the child, including child support, will be applied against the need standard in determining the Families First payment amount for the family. The child will be considered a Families First recipient for all other purposes, including Medicaid/TennCare coverage.

RULEMAKING HEARINGS

The family benefit cap will not apply to a subsequent period of eligibility for families who reapply for Families First subsequent to receipt of cash assistance for an eighteen (18)-month eligibility period during which the child was born, as long as the reason for prior case closure was other than a failure to comply with work or child support enforcement requirements or other Personal Responsibility Plan provisions, and the parent/caretaker had cooperated with the Department as defined in departmental policies for the Families First program.

- (i) Departmental policies and rules with which the parent/caretaker must cooperate include, but are not limited to:
 - (I) Child support cooperation requirements, such as identifying the absent parent, meeting with child support enforcement staff, submitting a child for blood testing, and testifying in court if necessary;
 - (II) Carrying out and fulfilling Personal Responsibility Plan provisions and requirements; or
 - (III) Carrying out and fulfilling Work Plan provisions and requirements.
- (f) An assistance payment is determined as follows:
 - 1. If the assistance group's net income (after allowable exclusions and deductions) equals or exceeds their consolidated need, the assistance group is not eligible.
 - 2. If the assistance group's net income is less than their consolidated need, the monthly grant amount is the smaller of a maximum payment amount by family size (SPA or DGPA, as appropriate) or the deficit if it is ten dollars (\$10) or more. If the deficit is one dollar (\$1) - nine dollars (\$9), the AG is eligible for Medicaid (TennCare) only, and is deemed to be a Families First recipient group.

In the case of an AG receiving Families First because one or both parents are unemployed, if the Principal Wage Earner (PWE) receives Unemployment Compensation (UC) the UC benefit is deducted from the grant amount determined after deducting all other countable income from the CNS, to determine the actual amount of Families First payment for the AG.
 - 3. The minimum monthly grant which can be paid is ten dollars (\$10).

RULEMAKING HEARINGS

(g) Families First Need/Payment Standards

1. Tables

TABLE I

Number of Persons in Assistance Group	1	2	3	4	5	6	7	8	9	10
Gross Income Standard	1141	1469	1743	1972	2163	2322	2455	2570	2671	2760
Consolidated Need Standard	617	794	942	1066	1169	1255	1327	1389	1444	1492
Maximum Payment (SPA)	95	142	185	226	264	305	345	386	425	467

Minimum Families First Payment is \$10 per month for any Assistance Group

Number of Persons in Assistance Group	11	12	13	14	15	16	17	18	19	20
Gross Income Standard	2842	2917	2988	3056	3119	3176	3228	3269	3299	3310
Consolidated Need Standard	1536	1577	1615	1652	1686	1717	1745	1767	1783	1789
Maximum Payment (SPA)	508	549	589	630	670	711	750	790	831	871

Minimum Families First Payment is \$10 per month for any Assistance Group

RULEMAKING HEARINGS

TABLE II

Number of Persons in Assistance Group	1	2	3	4	5	6	7	8	9	10
Gross Income Standard	1141	1469	1743	1972	2163	2322	2455	2570	2671	2760
Consolidated Need Standard	617	794	942	1066	1169	1255	1327	1389	1444	1492
Maximum Payment (DGPA)	140	192	232	242	291	305	345	386	425	467
Minimum Families First Payment is \$10 per month for any Assistance Group	11	12	13	14	15	16	17	18	19	20
Number of Persons in Assistance Group										
Gross Income Standard	2842	2917	2988	3056	3119	3176	3228	3269	3299	3310
Consolidated Need Standard	1536	1577	1615	1652	1686	1717	1745	1767	1783	1789
Maximum Payment (DGPA)	508	549	589	630	670	711	750	790	831	871

Minimum Families First Payment is \$10 per month for any Assistance Group

The Families First standard payment amount (maximum payment) for an assistance group of three (3) persons represents 19.6% of the consolidated need for an assistance group of that size. The Families First maximum differential grant payment amount for an assistance group of three (3) persons represents 24.6% of the consolidated need for an assistance group of that size. The payments for groups composed of different numbers of recipients represent an upward or downward adjustment of the percentage in the preceding sentences which is necessary to maintain the payment at a level not more or less than that paid in fiscal year 2004-2005.

3. Standard for Families First Transitional Services

- (i) Families First assistance groups and other low income families may receive transitional services after the Families First case closes.
- (ii) For purposes of this Part, “transitional services” is defined as services to assist the customer in attaining long-term self-sufficiency.
- (iii) Transitional services will be provided subject to the continued availability of state and/or federal funding.

RULEMAKING HEARINGS

- (iv) In order to receive these services, the assistance group's gross monthly income must meet a standard of need.

- (v) The standard of need for transitional services under this Part is defined as Two Hundred Percent (200%) of the Federal poverty level for the assistance group family size. The standard of need for this Part does not apply to Transitional Child Care or Transitional Medicaid.

Authority: TCA §§ 4-5-201 et seq.; 71-1-105; 71-3-151—71-3-165, 71-3-154(i); 71-3-155(e)-(g); Senate Bill 2315/House Bill 2331 (2005); 42 USCA §§ 601 et seq.; 45 CFR 233.20; and 42 USCA § 1315.

The notice of rulemaking set out herein was properly filed in the Department of State on the 31st day of May, 2005. (05-46)

RULEMAKING HEARINGS

BOARD OF MEDICAL EXAMINERS - 0880

There will be a hearing before the Tennessee Board of Medical Examiners to consider the promulgation of amendments to rules pursuant to T.C.A. §§ 4-5-202, 4-5-204, 48-101-610, 48-101-618, 48-101-630, 48-248-401, 48-248-404, 48-248-501, 48-248-603, 63-6-101, 63-6-204, 63-6-210, 63-6-224, 63-6-230, 63-6-233, 63-6-236, and Public Chapter 59 of the Public Acts of 2005. The hearing will be conducted in the manner prescribed by the Uniform Administrative Procedures Act, Tennessee Code Annotated, Section 4-5-204 and will take place in the Cumberland Room of the Cordell Hull Building located at 425 Fifth Avenue North, Nashville, TN at 10:30 a.m. (CDT) on the 18th day of July, 2005.

Any individuals with disabilities who wish to participate in these proceedings (review these filings) should contact the Department of Health, Division of Health Related Boards to discuss any auxiliary aids or services needed to facilitate such participation or review. Such initial contact may be made no less than ten (10) days prior to the scheduled meeting date (the date such party intends to review such filings), to allow time for the Division to determine how it may reasonably provide such aid or service. Initial contact may be made with the ADA Coordinator at the Division of Health Related Boards, First Floor, Cordell Hull Building, 425 Fifth Avenue North, Nashville, TN 37247-1010, (615) 532-4397.

For a copy of the entire text of this notice of rulemaking hearing contact:

Jerry Kosten, Regulations Manager, Division of Health Related Boards, 425 Fifth Avenue North, First Floor, Cordell Hull Building, Nashville, TN 37247-1010, (615) 532-4397.

SUBSTANCE OF PROPOSED RULES

AMENDMENTS

Rule 0880-2-.09 Licensure Renewal and Reinstatement, is amended by deleting subparagraph (2) (d) in its entirety and substituting instead the following language, so that as amended, the new subparagraph (2) (d) shall read:

- (2) (d) Submit, along with the application, documentation of successful completion of the continuing medical education requirements provided in rule 0880-2-.19 for all the calendar years (January 1 – December 31) that the license was expired that precede the calendar year during which the reinstatement is requested. Unless the licensee has actively practiced medicine in another state while the Tennessee license has been expired, none of the required continuing medical education shall be taken via the Internet or other electronic means.

Authority: T.C.A. §§4-5-202, 4-5-204, 63-6-101, 63-6-210, and 63-6-233.

0880-2-.10 Licensure Retirement/Inactivation and Reactivation, is amended by deleting subparagraph (3) (b) in its entirety and substituting instead the following language, so that as amended, the new subparagraph (3) (b) shall read:

- (3) (b) Submit, along with the application, documentation of successful completion of the continuing medical education requirements provided in rule 0880-2-.19 obtained within two (2) years preceding the reactivation request. Unless the licensee has practiced pursuant to rule 0880-2-.22 or has actively practiced medicine in another state while the Tennessee license

RULEMAKING HEARINGS

has been inactivated or retired, none of the required continuing medical education shall be taken via the Internet or other electronic means.

Authority: T.C.A. §§4-5-202, 4-5-204, 63-6-101, 63-6-210, 63-6-230, and 63-6-233.

Rule 0880-2-.14 Specially Regulated Areas and Aspects of Medical Practice, is amended by deleting paragraph (4) in its entirety and substituting instead the following language, so that as amended, the new paragraph (4) shall read:

- (4) Prescription writing shall be governed by T.C.A. § 63-6-236.

Authority: T.C.A. §§ 4-5-202, 4-5-204, 63-6-101, 63-6-204, and 63-6-236.

Rule 0880-2-.20 Medical Professional Corporations and Medical Professional Limited Liability Companies, is amended by adding the following language as part (1) (b) 9., and is further amended by deleting part (1) (c) 1. but not its subparts, and substituting instead the following language, and is further amended by deleting part (1) (c) 2. in its entirety and substituting instead the following language, and is further amended by adding the following language as part (2) (b) 9., and is further amended by deleting part (2) (c) 1. but not its subparts, and substituting instead the following language, and is further amended by deleting part (2) (c) 2. in its entirety and substituting instead the following language, so that as amended, the new part (1) (b) 9., the new part (1) (c) 1. but not its subparts, the new parts (1) (c) 2. and (2) (b) (9), the new part (2) (c) 1. but not its subparts, and the new part (2) (c) 2. shall read:

- (1) (b) 9. A foreign or domestic physician assistant general partnership, physician assistant professional corporation or physician assistant professional limited liability company doing business in Tennessee in which all shareholders/members are either physician assistants licensed pursuant to Tennessee Code Annotated Title 63, Chapter 19, Part 1 and/or physicians licensed pursuant to Tennessee Code Annotated Title 63, Chapter 6 and/or Chapter 9 or composed of entities which are directly or indirectly owned by such licensed physician assistants and/or physicians.
- (1) (c) 1. All, except the following officers, must be persons who are eligible to form or own shares of stock in a medical professional corporation as limited by T.C.A. § 48-101-610 (d) (1), (2), (3) and/or (4) and subparagraph (1) (b) of this rule:
- (1) (c) 2. With respect to members of the Board of Directors, only persons who are eligible to form or own shares of stock in a medical professional corporation as limited by T.C.A. § 48-101-610 (d) (1), (2), (3) and/or (4) and subparagraph (1) (b) of this rule shall be directors of a MPC.
- (2) (b) 9. A foreign or domestic physician assistant general partnership, physician assistant professional corporation or physician assistant professional limited liability company doing business in Tennessee in which all shareholders/members are either physician assistants licensed pursuant to Tennessee Code Annotated Title 63, Chapter 19, Part 1 and/or physicians licensed pursuant to Tennessee Code Annotated Title 63, Chapter 6 and/or Chapter 9 or composed of entities which are directly or indirectly owned by such licensed physician assistants and/or physicians.

RULEMAKING HEARINGS

- (2) (c) 1. All, except the following managers, must be persons who are eligible to form or own shares of stock in a medical professional limited liability company as limited by T.C.A. § 48-248-401 (d) (1), (2), (3) and/or (4) and subparagraph (2) (b) of this rule:
- (2) (c) 2. Only persons who are eligible to form or become members of a medical professional limited liability company as limited by T.C.A. § 48-248-401 (d) (1), (2), (3) and/or (4) and subparagraph (1) (b) of this rule shall be allowed to serve on the Board of Governors of a MPLLC.

Authority: T.C.A. §§ 4-5-202, 4-5-204, 48-101-610, 48-101-618, 48-101-630, 48-248-401, 48-248-404, 48-248-501, 48-248-603, 63-6-101, and Public Chapter 59 of the Public Acts of 2005.

Rule 0880-5-.01 Definitions, is amended by deleting paragraphs (2) and (3) in their entirety and substituting instead the following language, so that as amended, the new paragraphs (2) and (3) shall read:

- (2) Full Certification - Certification obtained by submitting certification issued by the A.R.R.T. which will enable the holder to perform, except for bone densitometry, any and all procedures or functions in a physician's office.
- (3) Limited Certification - Certification issued by the Tennessee Board of Medical Examiners which enables the holder to perform only those radiological procedures or functions intended for the body areas or specialty indicated on the issued certification, other than those procedures involving the administration of contrast media.

Authority: T.C.A. §§ 4-5-202, 4-5-204, 63-6-101, and 63-6-224.

Rule 0880-5-.10 Scope of Practice, is amended by deleting paragraph (4) in its entirety and substituting instead the following language, so that as amended, the new paragraph (4) shall read:

- (4) A.R.R.T. certificate holders are fully certified and may perform any and all radiographic procedures or functions in a physician's office that are within the American Society of Radiologic Technologists' (A.S.R.T.) scope of practice for radiographers.
 - (a) Performing bone densitometry is not considered to be within the A.S.R.T.'s scope of practice for radiographers.
 - (b) A.R.R.T. certificate holders who wish to perform bone densitometry and who receive initial certification as an x-ray operator in Tennessee after July 1, 2006 are required to:
 - 1. obtain the A.R.R.T.'s certification in bone densitometry (BD) by successfully completing the A.R.R.T.'s Bone Densitometry Clinical Experience Requirements; or
 - 2. obtain limited certification in bone densitometry, pursuant to Rule 0880-5-.11.

Authority: T.C.A. §§ 4-5-202, 4-5-204, 63-6-101, and 63-6-224.

RULEMAKING HEARINGS

Rule 0880-5-.11 Bone Densitometry, is amended by deleting parts (3) (a) 5. and (3) (a) 6. in their entirety and substituting instead the following language, and is further amended by deleting subparagraph (3) (c) in its entirety and renumbering the remaining subparagraphs accordingly, so that as amended, the new parts (3) (a) 5. and (3) (a) 6. shall read:

- (3) (a) 5. Cause to have submitted verification of attendance and successful completion of a Board-approved radiological certification training course; and
- (3) (a) 6. Have successfully completed the Board-approved examination pursuant to subparagraph (4) (f) of this rule; and

Authority: T.C.A. §§ 4-5-202, 4-5-204, 63-6-101, and 63-6-224.

The notice of rulemaking set out herein was properly filed in the Department of State on the 17th day of May, 2005. (05-15)

RULEMAKING HEARINGS

BOARD OF NURSING - 1000

There will be a hearing before the Tennessee Board of Nursing to consider the promulgation of amendments to rules pursuant to T.C.A. §§ 4-5-202, 4-5-204, and 63-7-207. The hearing will be conducted in the manner prescribed by the Uniform Administrative Procedures Act, Tennessee Code Annotated, Section 4-5-204 and will take place in the Cumberland Room of the Cordell Hull Building located at 425 Fifth Avenue North, Nashville, TN at 2:30 p.m. (CDT) on the 9th day of August, 2005.

Any individuals with disabilities who wish to participate in these proceedings (review these filings) should contact the Department of Health, Division of Health Related Boards to discuss any auxiliary aids or services needed to facilitate such participation or review. Such initial contact may be made no less than ten (10) days prior to the scheduled meeting date (the date such party intends to review such filings), to allow time for the Division to determine how it may reasonably provide such aid or service. Initial contact may be made with the ADA Coordinator at the Division of Health Related Boards, First Floor, Cordell Hull Building, 425 Fifth Avenue North, Nashville, TN 37247-1010, (615) 532-4397.

For a copy of the entire text of this notice of rulemaking hearing contact:

Jerry Kosten, Regulations Manager, Division of Health Related Boards, 425 Fifth Avenue North, First Floor, Cordell Hull Building, Nashville, TN 37247-1010, (615) 532-4397.

SUBSTANCE OF PROPOSED RULES

AMENDMENTS

Rule 1000-1-.04, Discipline of Licensees, Unauthorized Practice of Professional Nursing, Civil Penalties, Screening Panels, Subpoenas, Advisory Rulings, Declaratory Orders, and Assessment of Costs, is amended by deleting paragraph (5) in its entirety and renumbering the remaining paragraphs accordingly.

Authority: T.C.A. §§ 4-5-202, 4-5-204, 63-7-115, 63-7-116, and 63-7-207.

Rule 1000-2-.04, Discipline of Licensees, Unauthorized Practice of Practical Nursing, Civil Penalties, Screening Panels, Subpoenas, Advisory Rulings, Declaratory Orders, and Assessment of Costs, is amended by deleting paragraph (5) in its entirety and renumbering the remaining paragraphs accordingly.

Authority: T.C.A. §§ 4-5-202, 4-5-204, 63-7-115, 63-7-116, and 63-7-207.

The notice of rulemaking set out herein was properly filed in the Department of State on the 11th day of mMay, 2005. (0510)

TENNESSEE WILDLIFE RESOURCES COMMISSION

**PROCLAMATION 05-02
AMENDMENT TO PROCLAMATION 04-18
SPORT FISHING**

Pursuant to the authority granted by Title 70, Tennessee Code Annotated, and Sections 70-4-107 and 70-4-119 thereof, the Tennessee Wildlife Resources Commission proclaims the following amendment to Proclamation 04-18.

In Section X, under Giggling, Grabbling, Grab Hooking, Snagging, Tubbing, Archery, Spear-Gun Fishing, Dipping, and Cast Netting, change number 7 to "All Streams in the following counties closed year-round to gigging, but are open to all other methods identified in Section X:"

-Bedford	-Lawrence	-Maury
-Giles	-Lewis	-Wayne
-Hickman	-Marshall	

Proclamation 05-02 received and recorded this 3rd day of May, 2005. (05-03)

WILDLIFE PROCLAMATIONS

TENNESSEE WILDLIFE RESOURCES COMMISSION - 1660

PROCLAMATION 05-03

AMENDING PROCLAMATION 75-12 JOHNSON BOTTOMS, NATHAN BEDFORD FORREST STATE PARK, AND VOLUNTEER ARMY AMMUNITION PLANT WILDLIFE MANAGEMENT AREAS

Pursuant to the authority granted by Title 70, Tennessee Code Annotated, Section 70-1-206, the Tennessee Wildlife Resources Commission hereby amends proclamation 75-12 by deleting Section III in its entirety and replacing it with the following:

That area of Hamilton County consisting of lands formerly owned and delineated by the Department of the Army and transferred to Hamilton County and the City of Chattanooga known as the Volunteer Army Ammunition Plant, to be known as the Volunteer Army Ammunition Plant Wildlife Management Area.

Proclamation No. 05-03 received and recorded this 31st day of May, 2005. (05-29)

WILDLIFE PROCLAMATIONS

TENNESSEE WILDLIFE RESOURCES COMMISSION - 1660

**PROCLAMATION 05-04
PROCLAIMING MAPLE SPRINGS WILDLIFE MANAGEMENT AREA**

Pursuant to the authority granted by Title 70, Tennessee Code Annotated, Sections 70-1-206 and 70-5-101, the Tennessee Wildlife Resources Commission hereby proclaims the area known as Lovell Field Wildlife Management Area as no longer under the management of the Tennessee Wildlife Resources Agency, therefore, this proclamation repeals Proclamation 02-10 dated August 29, 2002.

Proclamation No. 05-04 received and recorded this 31st day of May, 2005. (05-30)

WILDLIFE PROCLAMATIONS

TENNESSEE WILDLIFE RESOURCES COMMISSION - 1660

PROCLAMATION 05-05

PROCLAIMING MAPLE SPRINGS WILDLIFE MANAGEMENT AREA

Pursuant to the authority granted by Title 70, Tennessee Code Annotated, Sections 70-1-206 and 70-5-101, the Tennessee Wildlife Resources Commission hereby proclaims the following area as a wildlife management area to be known as the Maple Springs Wildlife Management Area.

1. Maple Springs Wildlife Management Area – Those lands located in Coffee County, Tennessee, north of Manchester consisting of 50 acres.

The boundary line is posted with “Wildlife Management Area” signs. A more complete description may be found on file in the Real Estate Division office of Tennessee Wildlife Resources Agency, Nashville, Tennessee.

Proclamation No. 05-05 received and recorded this 31st day of May, 2005. (05-31)

WILDLIFE PROCLAMATIONS

TENNESSEE WILDLIFE RESOURCES COMMISSION - 1660

**PROCLAMATION 05-06
PROCLAIMING MINGO SWAMP WILDLIFE MANAGEMENT AREA**

Pursuant to the authority granted by Title 70, Tennessee Code Annotated, Sections 70-1-206 and 70-5-101, the Tennessee Wildlife Resources Commission hereby proclaims the following area as a wildlife management area to be known as the Mingo Swamp Wildlife Management Area.

1. Mingo Swamp Wildlife Management Area – Those lands located in Franklin County, Tennessee, west of Winchester consisting of 370 acres.

The boundary line is posted with “Wildlife Management Area” signs. A more complete description may be found on file in the Real Estate Division office of Tennessee Wildlife Resources Agency, Nashville, Tennessee.

Proclamation No. 05-06 received and recorded this 31st day of May, 2005. (05-32)

WILDLIFE PROCLAMATIONS

TENNESSEE WILDLIFE RESOURCES COMMISSION - 1660

**PROCLAMATION 05-07
PROCLAIMING OWL HOLLOW MILL WILDLIFE MANAGEMENT AREA**

Pursuant to the authority granted by Title 70, Tennessee Code Annotated, Sections 70-1-206 and 70-5-101, the Tennessee Wildlife Resources Commission hereby proclaims the following area as a wildlife management area to be known as the Owl Hollow Mill Wildlife Management Area.

1. Owl Hollow Mill Wildlife Management Area – Those state lands bordering Tims Ford Reservoir in Franklin County, Tennessee consisting of approximately 3,000 acres located in the Hurricane and Owl Hollow Creek drainages.

The boundary line is posted with “Wildlife Management Area” signs. A more complete description may be found on file in the Real Estate Division office of Tennessee Wildlife Resources Agency, Nashville, Tennessee.

Proclamation No. 05-07 received and recorded this 31st day of May, 2005. (05-33)

WILDLIFE PROCLAMATIONS

TENNESSEE WILDLIFE RESOURCES COMMISSION - 1660

PROCLAMATION 05-08

PROCLAIMING SHELTON FERRY WILDLIFE MANAGEMENT AREA

Pursuant to the authority granted by Title 70, Tennessee Code Annotated, Sections 70-1-206 and 70-5-101, the Tennessee Wildlife Resources Commission hereby proclaims the following area as a wildlife management area to be known as the Shelton Ferry Wildlife Management Area.

1. Shelton Ferry Wildlife Management Area - Those lands and waters located in Montgomery County, Tennessee, known as the Shelton Ferry Tract consisting of approximately 628 acres and owned by Tennessee Wildlife Resources Agency.

This tract is posted with "Wildlife Management Area" signs along the boundary lines. A more complete description for this tract may be found on file in the Real Estate Division office of Tennessee Wildlife Resources Agency, Nashville, Tennessee.

Proclamation No. 05-08 received and recorded this 31st day of May, (05-34).

WILDLIFE PROCLAMATIONS

TENNESSEE WILDLIFE RESOURCES COMMISSION - 1660

PROCLAMATION 05-09 MANNER AND MEANS OF HUNTING, TAKING, AND TRAPPING STATEWIDE AND ON WILDLIFE MANAGEMENT AREAS AND STATE REFUGES

Pursuant to the authority granted by Tennessee Code Annotated, Section 70-4-107 and 70-5-108, the Tennessee Wildlife Resources Commission hereby proclaims the manner and means of hunting, taking, and trapping, effective August 1, 2005.

NOTE: All sections contained herein apply to statewide and management area hunting. Special restrictions may apply on some wildlife management areas. Legislative Private Acts also apply in some counties.

SECTION I. ILLEGAL WEAPONS

- (1) Shotguns using ammunition loaded with shot larger than Number four (4) are prohibited for hunting all wildlife except beavers, coyotes and waterfowl.
- (2) Shotguns loaded with single ball or rifled slug ammunition are prohibited for hunting all wildlife except deer, bear, boar and feral hogs¹ except as follows: Coyotes and bobcats may be taken by big game hunters while hunting big game with any legal big game weapon or ammunition.
- (3) Rifles or handguns loaded with military or other full metal jacketed type of ammunition are prohibited.
- (4) Rifles or handguns loaded with center-fire ammunition are prohibited for all hunting between 30 minutes after sunset and 30 minutes before sunrise.
- (5) Rifles or handguns loaded with center-fire ammunition are prohibited during all deer, bear or boar seasons for hunting any wildlife except deer, bear, or boar. Coyotes, crows, groundhogs, beaver, feral hogs, foxes and bobcats may be taken by big game hunters while hunting big game with any legal big game weapon or ammunition as provided in the Big Game Season Proclamation.
- (6) Any arrow with poisoned or chemically treated tip or explosive head is illegal for hunting.
- (7) Weapons capable of fully automatic fire are prohibited for hunting of all wildlife.
- (8) Firearms or archery equipment with any device utilizing an artificial light capable of locating wildlife.

SECTION II. PROHIBITED ACTS

- (1) The use or possession of predator calls while night hunting of any species is prohibited.

¹ Feral hogs are defined as any wild hog found in Tennessee, except on Catoosa, South Cherokee, Cove Mountain, and Foothills WMAs.

WILDLIFE PROCLAMATIONS

- (2) The use or possession and/or the accompanying of anyone using or possessing raccoon calls, squallers, weapons, ammunition, or climbers while training dogs is prohibited during training season, except raccoon calls may be used during authorized field trials.
- (3) The use of dogs in taking or attempting to take deer is prohibited. Taking or attempting to take deer being pursued by dog, or dogs, is prohibited.
- (4) The use or possession of a pod arrow, any pod-type device for holding drugs or chemicals on an arrow, or any drugs or chemicals used in pod arrows while archery hunting is prohibited.
- (5) Quota hunt permits are not transferable. Anyone found hunting on a borrowed quota permit shall be deemed guilty of hunting in closed season.
- (6) Juveniles under the age of eighteen (18) are prohibited from using handguns for the purpose of hunting.
- (7) Hunting prohibited over a site where bait has been placed to feed or attract wildlife unless the bait has been removed at least ten days prior to hunting.
- (8) Evidence of species or sex of big game animals shall not be destroyed or removed prior to a permanent kill tag being issued at a checking station. (normal field dressing is permitted)
- (9) Possession of firearms prohibited while chasing coyote, fox, and bobcat with dogs from the first Saturday in November through the end of the deer season.
- (10) Use or possession of any electronic light amplifying night vision scope or device is prohibited when in possession of a firearm or archery tackle between sunset and sunrise.
- (11) Use or possession of electronic calls and live decoys prohibited while hunting wild turkey.
- (12) Possession of agricultural grain on one's person while turkey hunting is prohibited.

SECTION III. LEGAL WEAPONS

- (1) Turkey Hunting
 - (a) Shotguns 20 gauge or larger using ammunition loaded with number 4 shot or smaller.
 - (b) Longbows, compound bows and crossbows.
 - (c) Weapons may be equipped with sighting devices except those devices utilizing an artificial light capable of locating wildlife.
- (2) Deer, Bear, Boar and Feral Hog Hunting
 - (a) Shotguns using ammunition loaded with single solid ball or rifled slugs.
 - (b) Rifles, except those described in Section I. (3) above, using center- fire ammunition of .24 caliber or larger, in all counties except where regulated by legislative acts.

WILDLIFE PROCLAMATIONS

- (c) Muzzle-loading percussion cap or flintlock rifles, handguns or shotguns of .40 caliber (.40") minimum. These muzzle-loading firearms are legal during any gun season or hunt unless otherwise specified. Muzzleloading firearms are defined as those firearms which are incapable of being loaded from the breech.
 - (d) Longbows, compound bows and crossbows.
 - (e) Hunting arrows and bolts shall be of a barbless design and shall have sharpened blades.
 - (f) Center-fire handguns .24 caliber or larger having a barrel length of four (4) inches or more, in all counties except where regulated by legislative acts.
 - (g) Weapons may be equipped with sighting devices except those devices utilizing an artificial light capable of locating wildlife.
- (3) Small Game Hunting
- (a) Shotguns and handguns using ammunition loaded with Number Four (4) or smaller shot are legal for all small game hunting.
 - (b) Shotguns using ammunition loaded with BBB (0.19 inch diameter) or smaller shot are legal for hunting coyotes and beaver except during big game seasons.
 - (c) Shotguns loaded with nontoxic shot approved by the U. S. Fish and Wildlife Service are legal for hunting waterfowl.
 - (d) Rifles and handguns using rim-fire ammunition and air rifles are legal for hunting small game except migratory birds.
 - (e) Rifles and handguns using center-fire ammunition are legal for hunting beaver, bobcat, foxes, coyotes, feral hogs, groundhogs, and crows, except during deer, bear or boar seasons. Rifles and handguns using center-fire ammunition prohibited for hunting all small game species on wildlife management areas (except as specified in Section I.(2) and (5) above)
 - (f) Muzzle-loading firearms (rifles, handguns and shotguns).
 - (g) Longbows, compound bows and crossbows.
 - (h) Falcons and Falconry – Subject to Tennessee Code Annotated Section 70-414.
 - (i) Gigs and angling equipment are also legal for taking bullfrogs.
 - (j) Weapons may be equipped with sighting devices except those devices utilizing an artificial light capable of locating wildlife.

SECTION IV. LEGAL TRAPPING DEVICES AND DEFINITIONS

- (1) Leg-hold traps with a jaw spread of 7 1/2 inches or less are legal for all furbearer species during the legal trapping season.

WILDLIFE PROCLAMATIONS

- (2) Instant-kill traps with jaw measurements no greater than 10 x 10 inches and smaller are legal for all furbearer species during the legal trapping season. Instant kill traps are considered steel jawed traps and their use is restricted to that allowed for steel jawed traps.
- (3) Live traps are legal for taking any species of wildlife listed as having a trapping season. Live traps are defined as those traps that act as a cage after capture.
- (4) Steel cable snares having a minimum cable diameter of 5/64 inch and a maximum cable diameter of 3/32 inch are legal for all legal furbearer species during the legal trapping season. All snares shall have affixed a tag bearing the name of the owner. Spring activated snares other than Collarum snares prohibited.
- (5) Cushion-hold traps are legal for all furbearer species during the legal trapping season. The Woodstream Soft-Catch, Duke Rubber Jaw Trap, Butera Cushion Catch traps, Cushion Catch #33 Trap, J. C. Conner Coyote "Jake" Trap, and any legal sized offset jawed traps equipped with Humane Hold universal pads by KG Enterprises meet the definition of a "cushion-hold trap" as provided in TCA 70-1-101 which may be used in accordance with TCA 70-4-120.
- (6) The following species specific traps - Egg Traps, Coon Cuffs, Lil' Grizz Getrz and Duffer's Raccoon Trap, are legal for furbearers during the legal trapping season.
- (7) For trapping purposes "water set" is defined to mean traps set in water adjacent to and part of streams, ponds, lakes, wetlands or other water courses and includes floating sets.

SECTION V. AMMUNITION

- (1) Possession of ammunition except that as specifically authorized is prohibited on all wildlife management areas, state refuges, and public hunting areas.
- (2) Possession or use of buckshot is specifically prohibited while hunting all species, except in those counties where authorized by Private Acts.
- (3) Possession of shotgun ammunition loaded with more than one solid ball is specifically prohibited while hunting deer, bear, boar or feral hogs except in those counties where legal by Private Act.
- (4) Possession of shot larger than No. 4 is prohibited when hunting all wildlife except waterfowl, coyotes and beaver.
- (5) Possession of rifled slugs is prohibited except while hunting deer, bear, boar and feral hogs.
- (6) Possession or use of any loose shot other than non-toxic (as approved by U.S Fish and Wildlife Service) or any shotgun shell loaded with shot other than non-toxic is prohibited while hunting waterfowl, coots, gallinules, Virginia rails, and sora rails.

WILDLIFE PROCLAMATIONS

SECTION VI. POSSESSION OF LIVE ANIMALS

Every game animal, wounded or unwounded by hunting and/or trapping and taken into possession by the hunter or trapper, shall be immediately slain and become part of the daily bag limit. No person shall, at any time, or by any means, possess or transport live animals taken under the authority of hunting season proclamations.

SECTION VII. LEGAL HUNTING HOURS

- (1) All big game and small game species (except bullfrogs, raccoons, opossums, migratory birds, and the chasing of foxes) daylight hours only (30 minutes before official sunrise and until 30 minutes after official sunset) except turkey open only until official sunset.
- (2) Hunting of bullfrogs, raccoons, opossums, the chasing of foxes and the trapping of furbearers is permitted day or night unless restricted by Proclamation.
- (3) Migratory birds - To comply with federal regulations for migratory birds, unless restricted by proclamation.

SECTION VIII. MISCELLANEOUS MIGRATORY BIRD REGULATIONS

- (1) Federal regulations relative to baiting, firearms, bag and possession limits, wanton waste, tagging, and methods of hunting are hereby adopted and will be applicable to hunting and/or taking of species listed.
- (2) No person shall hunt migratory game birds with a shotgun of any description capable of holding more than three (3) shells, unless it is plugged with a one-piece filler, incapable of removal without disassembling the gun, so its total capacity does not exceed three (3) shells.
- (3) All persons who hunt migratory game birds are required to have in their possession a valid Tennessee Migratory Bird Permit (TMBP) in addition to other required Tennessee licenses and permits, with the following exceptions:
 - (a) disabled veterans
 - (b) landowners hunting on their own land
 - (c) lifetime license holders
 - (d) residents of Tennessee under 13 years of age
 - (e) residents of Tennessee who are 65 or older

Military personnel on leave or furlough will be required to possess the TMBP when hunting migratory game birds even though they are not required to possess a hunting and fishing license.

- (4) Refer to federal regulations 50 CFR Ch. 1 (21.41 and 21.43) for conditions and restrictions applicable to the taking of crows in certain depredation or health hazard situations outside of the crow sport hunting season.

WILDLIFE PROCLAMATIONS

SECTION IX. REPEAL OF PRIOR PROCLAMATION

This proclamation repeals Proclamation No. 04-6 dated May 20, 2004 .

Proclamation No. 05-09 received and recorded the 31st day of May, 2005. (05-35)

WILDLIFE PROCLAMATIONS

TENNESSEE WILDLIFE RESOURCES COMMISSION - 1660

**PROCLAMATION 05-10
CONTROLLED AND COMMERCIAL SHOOTING PRESERVES
HUNTING SEASONS AND BAG LIMITS**

Pursuant to the authority granted by Tennessee Code Annotated, Section 70-4-107 and 70-5-108, the Tennessee Wildlife Resources Commission hereby proclaims the controlled and commercial shooting preserves hunting and bag limits effective August 1, 2005.

SECTION I. CONTROLLED AND COMMERCIAL SHOOTING PRESERVES

	Opens	Closes	Daily Bag
Upland Game Birds	Year-round		No Limit
Waterfowl	March 15	October 15	No Limit
Big Game - (Feral Hogs and Exotic Species only, excluding Exotic Cats and all species of Bear)(Dogs may be used in the hunting of swine)	Year-round		No Limit
Small Game Mammals (fenced enclosures only) Bobcat specifically prohibited	Year-round		No Limit

Native wildlife species naturally occurring in a preserve must be hunted and harvested in accordance with statewide regulations, license and permit requirements. Captive Elk are regarded as Class III wildlife in a preserve.

Any wildlife authorized for release on the wildlife preserve may be taken with gun, archery equipment or trap.

SECTION VI. REPEAL OF PRIOR PROCLAMATIONS

This proclamation repeals Section II of Proclamation No. 04-08 dated May 20, 2004

Proclamation No. 05-10, received and recorded this 31st day of May, 2005. (05-36)

WILDLIFE PROCLAMATIONS

TENNESSEE WILDLIFE RESOURCES COMMISSION - 1660

**PROCLAMATION 05-11
OPENING**

HATCHIE, LOWER HATCHIE, REELFOOT, LAKE ISOM, CROSS CREEKS, CHICKASAW, AND TENNESSEE NATIONAL WILDLIFE REFUGES TO HUNTING

Pursuant to the authority granted by Tennessee code annotated sections, 70-4-107, 70-5-108 and 70-5-111 thereof, the Tennessee Wildlife Resources Commission, after making a survey of Hatchie, Lower Hatchie, Reelfoot, Lake Isom, Cross Creeks, Chickasaw, and Tennessee National Wildlife Refuges and finding that the supply of game is sufficient to allow hunting thereof as hereinafter described without the danger of extinction or depletion hereby proclaims the following regulations for the 2005-2006 season, effective August 1, 2005.

A federal permit required for all hunts. Quota permits are required for quota hunts and special federal regulations apply as specified. A signed refuge brochure serves as the permit for non-quota hunts.

All antlered deer taken on National Wildlife Refuges count toward the statewide antlered deer bag limit except on NWR quota hunts or as otherwise noted. Antler-less deer taken on NWR quota hunts or where specific NWR hunt dates are listed are bonus deer except as otherwise noted.

On all Young Sportsman Hunts, youth, ages 6-16, may participate but must be accompanied by an adult, 21 years of age or older, who must remain in a position to take immediate control of the hunting device. Adults cannot hunt except as indicated otherwise. Adults must comply with fluorescent orange regulations, as specified for legal hunters when accompanying young sportsmen on Young Sportsman Big Game Hunts, except as indicated. Youth, ages 6-16, may participate on other NWR hunts (big game, small game, waterfowl, etc.) but must be accompanied by an adult, 21 years of age or older, who must remain in a position to take immediate control of the hunting device, except as otherwise noted.

SECTION I. HATCHIE NATIONAL WILDLIFE REFUGE

Dove, Opossum, Quail, Rabbit,
Raccoon, Snipe, Squirrel and
Woodcock¹

Same as statewide seasons (except closed during deer hunts and no spring squirrel season).
Bag and possession limit same as statewide regulations.
Non-toxic shot only.

Deer (Archery)

One 16-day hunt. Sept. 24–Oct. 9, 2005. No hunter quota. Four deer, either sex (no more than two antlered). Counts in Unit A bag.

Deer (Archery/Muzzleloader/Gun)

Two 2-day hunts. Oct. 22-23, Nov. 12-13, 2005. Hunter quota 225 per hunt, plus 4 wheelchair bound hunters and their assistants per hunt. Two deer, either sex. Deer counts as a bonus deer. Deer taken on quota gun hunts must be checked out at the refuge check station.

¹ Opossum and raccoon - hunting hours from sunset to one hour before sunrise. Closed the night before and during any refuge deer seasons. Armadillo, beaver and coyote may be taken on any hunt. Non-toxic shot only.

WILDLIFE PROCLAMATIONS

Ducks, Geese and Coots²
(Porter Tract only)³

Tues., Thurs. and Sat. of both the early and regular statewide seasons (hunting until 12:00 noon only). Young Sportsmen hunt same as statewide season. Bag and possession limit in accordance with statewide regulations. Non-toxic shot only.

SECTION II. CHICKASAW AND LOWER HATCHIE NATIONAL WILDLIFE REFUGES

All small game and waterfowl hunting seasons and bag limits in accordance with statewide regulations (except closed during spring squirrel season). Raccoon, opossum, squirrel, rabbit, quail, dove, woodcock, and snipe hunting is closed during all young sportsmen deer, muzzleloader, and gun deer hunts. All hunting blinds will be portable and nothing of a permanent nature will be constructed. No axes or saws allowed on raccoon hunts. Waterfowl hunting until 12:00 Noon only. Temporary blinds and decoys must be removed at the end of each day's hunt. Non-toxic shot only.

Beaver and coyote may be taken during any scheduled hunt with any weapon legal for the hunt.

Deer (Archery)	Sept. 24- Oct. 28, Nov. 7-18, Dec. 12-16, 2005. No hunter quota. Four deer, either sex (no more than two antlered). Counts in Unit A bag.
Deer (Archery/Muzzleloader/Gun) (Young Sportsman)	Two 2-day hunts. Oct. 29-30, 2005; Jan. 14-15, 2006. No hunter quota. Two deer (no more than one antlered). Counts in Unit A bag.
Deer (Archery/Muzzleloader)	One 7-day hunt. Nov. 5-11, 2005. No hunter quota. Two deer (no more than one antlered). Counts in Unit A bag.
Deer (Archery/Muzzleloader/Gun)	One 16-day hunt. Nov. 19 - Dec. 4, 2005. No hunter quota. Two deer, buck only. Counts in Unit A bag.
Deer (Archery/Muzzleloader)	One 7-day hunt. Dec. 5-11, 2005. No hunter quota. Two deer (no more than one antlered). Counts in Unit A bag.
Deer (Archery/Muzzleloader/Gun)	One 23-day hunt. Dec. 17 2005 – Jan. 8, 2006. No hunter quota. Two deer, buck only. Counts in Unit A bag.

SECTION III. SUNK LAKE PUBLIC USE MANAGEMENT AREA (NORTHERN UNIT ONLY)

Squirrel, Rabbit, Quail,
Raccoon and Opossum

Season same as statewide. Spring squirrel season closed. Bag and possession limit same as statewide. Non-toxic shot only.

² Only portable blinds or blinds of native vegetation may be used. Blinds and decoys must be removed each day.

³ Porter Tract is that portion of the refuge that lies at the extreme east end of the refuge lying east of Richland Creek and the Big Eddy Road.

WILDLIFE PROCLAMATIONS

Deer (Archery only) Sept. 24- Oct. 28, Nov. 7-18, Dec. 12-16, 2005. No hunter quota. Four deer, either sex (no more than two antlered). Counts in Unit A bag.

SECTION IV. TENNESSEE NATIONAL WILDLIFE REFUGE

Special federal permit required (except designated closed areas). Beaver and coyote may be taken on a scheduled hunt for other species with any weapon legal for the hunt.

Deer (Primitive Weapons: long bow, recurve bow and side hammered muzzleloaders with iron sights only) One 2-day hunt. Sept. 17-18, 2005. Three deer (only one may be antlered). Hunter quota: Big Sandy Peninsula–150, Duck River Bottoms Unit–150, Duck River Uplands Unit–100, Britton Ford Peninsula–40, Busseltown–60. All deer harvested are bonus deer.

Deer (Archery/Muzzleloader/Gun) Three 2-day hunts. Oct. 15-16, 29-30, Nov. 12-13, 2005. Three deer (only one may be antlered). Hunters must harvest an antlerless deer before harvesting an antlered deer. Hunter quota: Big Sandy Peninsula–150, Duck River Bottoms Unit–150, Duck River Uplands Unit–100, Britton Ford Peninsula–40, Busseltown–60. All deer harvested are bonus deer.

Deer/Turkey (Archery) Same as statewide seasons through Nov. 14, 2005. No hunter quota. Closed during quota hunts. Four deer, either sex, (no more than two antlered). One turkey either sex. Deer and turkey count in Unit A bag limit.

Deer (Archery/Muzzleloader/Gun) (Young Sportsman) One 2-day hunt. Oct. 1-2, 2005. No hunter quota. Three deer, either sex (no more than one antlered, bonus deer).

Squirrel Aug. 27-Nov. 14, 2005. Closed during quota hunts. Bag and possession limits are same as statewide.

Raccoon Oct 31-Nov.3, Nov. 7-10, 2005. Bag and possession limits are same as statewide.

Canada Goose Same as statewide season until opening of early wood duck/teal season. Bag and possession limits in accordance with statewide regulations.

SECTION V. REELFOOT AND LAKE ISOM NATIONAL WILDLIFE REFUGES

Squirrel Aug. 27-Oct. 14, 2005. Spring squirrel season closed. Bag and possession limits in accordance with statewide season. Non-toxic shot only.

WILDLIFE PROCLAMATIONS

Raccoon	Sept. 30-Oct. 15, 2005. No limit. Hunting hours – 7:00 pm until midnight only. Hunters must check out all raccoons for tagging. Non-toxic shot only.
Deer (Archery)	Sept. 24-Oct. 28, 2005. No hunter quota. Four deer, either sex (no more than two antlered). Counts toward statewide bag limit.
Deer (Archery/Muzzleloader/Gun) (Reelfoot Refuge only)	One 3-day hunt. Nov. 11-13, 2005. Hunter quota–200 (100 permits for Long Point Unit and 100 permits for Grassy Island Unit). Two deer, either sex (no more than one antlered). All deer harvested are bonus deer. Harvested deer must be reported at refuge check station.

SECTION VI. CROSS CREEKS NATIONAL WILDLIFE REFUGE

No hunting in safety zones as listed in NWR pamphlet. All other hunting (squirrel, turkey, archery deer) will be closed on weekends when quota deer hunts are scheduled.

Squirrel Aug. 27-Nov. 14, 2005.	Bag and possession limit same as statewide. Closed when quota deer hunts are scheduled.
Deer (Archery)	One 2-day hunt. Sept. 17-18, 2005. Hunter quota: Southside: Northwest of Pool 5 Bridge–25, Southside: Southeast of Pool 5 Bridge–25, Northside of Cumberland River–50. Three deer, only one may be antlered. All deer harvested are bonus deer.
Deer (Archery/Muzzleloader/Gun)	Two 2-day hunts. Oct. 22-23, Nov. 5-6, 2005. Hunter quota : Southside: Northwest of Pool 5 Bridge–25, Southside: Southeast of Pool 5 Bridge–25, Northside of Cumberland River–50. Three deer (only one may be antlered). Hunters must harvest an antlerless deer before harvesting an antlered deer. All deer harvested are bonus deer.
Deer/Turkey (Archery)	Same as statewide seasons through Nov. 14, 2005. No hunter quota. Closed during quota hunts. Four deer, either sex, (no more than two antlered). One turkey either sex. Deer and turkey count in Unit A bag limit.
Deer (Archery/Muzzleloader/Gun) (Young Sportsman)	One 2-day hunt. Oct. 29-30, 2005. No hunter quota. Two deer either sex (no more than one antlered). Counts in Unit A bag.
Canada Goose	Same as statewide season until opening of early wood duck/teal season. Bag and possession limits in accordance with statewide regulations.

WILDLIFE PROCLAMATIONS

SECTION VII. GENERAL REGULATIONS FOR HUNTING NATIONAL WILDLIFE REFUGES

1. Vehicles must remain on established roads. Roads may be closed due to adverse weather conditions. Park vehicles in a manner that will not interfere with normal flow of traffic.
2. Camping and fires are prohibited except in designated areas.
3. It is unlawful to drive a nail, spike, or other metal object into any tree or to hunt from any tree in which a nail, spike, or other metal object has been driven.
4. Dogs are prohibited except when used during the small game and migratory bird hunts.
5. Designated areas of refuges will be closed to all public entry to provide sanctuaries for waterfowl.
6. Small game hunters may only possess and use shotgun shells containing non-toxic shot in areas designated as high waterfowl use areas.
7. Hunters must possess a signed refuge brochure/permit.
8. All fall turkey hunts open in open counties on National Wildlife Refuges close ½ hour after sunset on Nov. 14.

SECTION VIII. REPEAL OF PRIOR PROCLAMATIONS

This proclamation repeals proclamation No. 04-07 dated May 20, 2004.

Proclamation 05-11 received and recorded this 31st day of May, 2005. (05-37)

WILDLIFE PROCLAMATIONS

TENNESSEE WILDLIFE RESOURCES COMMISSION - 1660

**PROCLAMATION 05-12
STATEWIDE FURBEARER HUNTING AND TRAPPING SEASONS AND BAG LIMITS
(EXCLUSIVE OF WILDLIFE MANAGEMENT AREAS AND REFUGES)**

Pursuant to the authority granted by Tennessee Code Annotated, Section 70-4-107 and 70-5-108, the Tennessee Wildlife Resources Commission hereby proclaims the statewide furbearer hunting and trapping seasons and bag limits effective August 1, 2005.

SECTION I. HUNTING

Species	Opens	Closes	Daily Bag
Groundhog, Coyote, Nutria, Striped Skunk, Beaver	Year-round		No Limit
Fox, Mink, Muskrat, Spotted Skunk, Weasel	Friday before Thanksgiving	Feb. 15	No Limit

River Otter¹

Regions I, II and III. That portion of Tennessee as defined by TWRA regional boundaries as published

Opens	Closes	Daily Bag
Friday before Thanksgiving	Feb. 15	No Limit

Restrictive Experimental River Otter Season in all TWRA Region IV counties

Opens	Closes	Seasonal Bag ²
Friday before Thanksgiving	Dec. 31	4

Bobcat	Opens	Closes	Daily Bag
	Friday before Thanksgiving	Feb. 15	1

¹ All river otters harvested must be tagged by harvester with Tennessee US CITES tags.

² Aggregate bag limit: River otters taken by both hunting and trapping in TWRA Region IV shall not exceed 4 per harvester per season.

WILDLIFE PROCLAMATIONS

Raccoon, Opossum³

Western Unit

That portion of Tennessee west of and including Scott, Morgan, Roane, McMinn, and Bradley counties

	Opens	Closes	Daily Bag
Taking Season	Sunset 3rd Friday in September	Sunrise Feb. 15	2 per person per night ⁴
Training Season	Year-round except where regulated by Private Act		No Taking Permitted

Eastern Unit

That portion of Tennessee east of Scott, Morgan, Roane, McMinn, and Bradley counties

	Opens	Closes	Daily Bag
Taking Season	Sunset 1st Friday in November	Sunrise Feb. 15	2 per person per night ⁴
Training Season	Year-round except where regulated by Private Act		No Taking Permitted

SECTION II. TRAPPING

Species	Opens	Closes	Daily Bag
Groundhog, Coyote, Nutria, Beaver	Year-round		No Limit
Bobcat, Fox, Mink, Muskrat, Opossum, Raccoon, Spotted Skunk, Striped Skunk, Weasel	Friday before Thanksgiving	Feb. 15	No Limit

³ No limit on opossum

⁴ Night defined as one 24-hour period commencing at sunset.

WILDLIFE PROCLAMATIONS

River Otter ⁵

Regions I, II and III. That portion of Tennessee as defined by TWRA regional boundaries as published

Opens	Closes	Daily Bag
Friday before Thanksgiving	Feb. 15	No Limit

River Otter ⁶

Restrictive Experimental
River Otter Season in all
TWRA Region IV counties

Opens	Closes	Seasonal Bag ⁷
Friday before Thanksgiving	Dec. 31	4

The following counties are included in the statewide fox hunting and trapping seasons, after determining a need for the opening thereof:

Blount	Johnson	Overton
Carter	Knox	Pickett
Clay	Loudon	Putnam
Cocke	Macon	Rhea
Fentress	McMinn	Robertson
Hamblen	Meigs	Sevier
Haywood	Monroe	White
Jefferson		

SECTION VI. POSSESSION LIMITS

The possession limit for all species listed herein is twice the daily bag limit except opening day when it shall be the same as the daily bag limit.

SECTION VII. REPEAL OF PRIOR PROCLAMATION

This proclamation repeals Proclamations No. 04-09, dated May 20, 2004.

Proclamation No. 05-12 received and recorded this 31st day of May, 2005 (05-38).

⁶ All river otters harvested must be tagged by harvester with Tennessee US CITES tags.

⁷ Aggregate bag limit: River otters taken by both hunting and trapping in TWRA Region IV shall not exceed 4 per harvester per season.

WILDLIFE PROCLAMATIONS

TENNESSEE WILDLIFE RESOURCES COMMISSION - 1660

PROCLAMATION 05-13 STATEWIDE BIG GAME HUNTING SEASONS AND BAG LIMIT (EXCLUSIVE OF WILDLIFE MANAGEMENT AREAS AND REFUGES)

Pursuant to the authority granted by Tennessee Code Annotated Sections 70-4-107 and 70-5-108, the Tennessee Wildlife Resources Commission hereby proclaims the statewide big game seasons and bag limits, effective August 1, 2005.

SECTION I. WHITE-TAILED DEER

A. White-tailed Deer Hunting Units

For the purpose of these hunting regulations and better wildlife management, the State of Tennessee is hereby divided into three (3) deer units, as follows:

Unit

- A. Benton, Bledsoe, Bradley, Chester, Clay, Crockett, Decatur, DeKalb, Dyer, Franklin, Gibson, Grundy, Hamilton, Hardin, Haywood, Henderson, Houston, Jackson, Lake, Lauderdale, Marion, McMinn, McNairy, Meigs, Obion, Overton, Perry, Putnam, Rhea, Roane, Sequatchie, Shelby, Smith, Stewart, Tipton, Van Buren, Warren, White.
- B. Anderson, Blount, Campbell, Carter, Claiborne, Cocke, Cumberland, Fentress, Grainger, Greene, Hamblen, Hancock, Hawkins, Jefferson, Johnson, Knox, Loudon, Monroe, Morgan, Pickett, Polk, Scott, Sevier, Sullivan, Unicoi, Union, Washington.
- L. Bedford, Cannon, Carroll, Cheatham, Coffee, Davidson, Dickson, Fayette, Giles, Hardeman, Henry, Hickman, Humphreys, Lawrence, Lewis, Lincoln, Macon, Madison, Marshall, Maury, Montgomery, Moore, Robertson, Rutherford, Sumner, Trousdale, Wayne, Weakley, Williamson, Wilson.

B. White-tailed Deer Bag Limits and Season Dates

Statewide - Antlered Buck Bag Limit

The statewide bag limit for antlered bucks in Tennessee is three (3), except a hunter may take no more than two (2) antlered bucks from Unit B. No more than 1 antlered deer may be taken per day. The only way the bag limit of three antlered bucks may be exceeded is if bucks are taken on TWRA or NWR managed hunts where the bucks are noted as bonus deer in the section listing WMA regulations. Deer taken on Ft. Campbell are also bonus deer.

WILDLIFE PROCLAMATIONS

Units A and L - Bag Limits:

Season Type	Season Dates	Antlered Bag Limit		Antlerless Bag Limits	
		Unit A	Unit L	Unit A	Unit L
Archery	Sept. 24, 2005 - Oct. 28, 2005 Oct. 31, 2005 - Nov. 4, 2005 Nov. 12, 2005 - Nov. 18, 2005 Dec. 12, 2005 - Dec. 16, 2005	2	2	4	3/day
Muzzleloader	Nov. 5, 2005 - Nov. 11, 2005 Dec. 5, 2005 - Dec. 11, 2005	1 1	2	4	3/day
Gun	Nov. 19, 2005 - Dec. 4, 2005 Dec. 17, 2005 - Jan. 8, 2006	2	2	See Quota Hunt Table – Section C for antlerless hunts	3/day* (Type 94 permit required)
Young Sportsman**	Oct. 29 – Oct. 30, 2005 Jan. 14 – Jan 15, 2006	1 1	1 1	2 2	2 2

Unit B - Bag Limits:

Season Type	Season Dates	Deer Bag Limits (see Note below)
		Unit B
Archery	Sept. 24, 2005 - Oct. 28, 2005 Oct. 31, 2005 - Nov. 4, 2005 Nov. 12, 2005 - Nov. 18, 2005	2 deer, either sex
Muzzleloader	Nov. 5, 2005 - Nov. 11, 2005	1 deer, antlered only (this deer may be either sex Nov. 5-7)
	Dec. 9, 2005 - Dec. 11, 2005	1 deer, antlered only
Gun	Nov. 19, 2005 - Nov. 27, 2005 Dec. 17, 2005 - Jan. 4, 2006	2 deer, antlered only See Quota Hunt Table – Section C for antlerless hunts
Young Sportsman**	Oct. 29 – Oct. 30, 2005	1 deer, either sex
	Jan. 14 – Jan 15, 2006	1 deer, either sex

* A Type 94 permit is required to hunt antlerless deer during this season except for landowners hunting under the landowner exemption (as described in T.C.A. 70-2-204), Sportsman license holders (including Lifetime Sportsman), and hunters who possess a Type 167 permit.

** Youths 6-16 years of age may participate. Each young sportsman must be accompanied by a non-hunting, adult, 21 years of age or older, who must remain in a position to take immediate control of the hunting device and who must also comply with fluorescent orange regulations, as specified for legal hunters.

Note: The statewide antlered buck limit is three (3), except no more than two (2) antlered bucks may be harvested in Unit B. Antlered deer must have antlers a minimum of three inches (3") in length on buck only or antlered only hunts. Antlerless deer are defined as deer with no antlers or deer with antlers less than three inches (3") in length.

WILDLIFE PROCLAMATIONS

C. Antlerless White-tailed Deer Special Hunts

The following counties and portions of counties are open to antlerless deer hunting during the regular gun season as specified.

Quota Hunts -- Special quota permit required, except for landowners hunting under the landowner exemption (as described in T.C.A. 70-2-204). Bag limit-one deer per permit except where noted.

Note: Anderson and Blount county allow a bag limit of 2 deer per permit.

Franklin and Smith county allow a bag limit of 3 deer per permit.

Non-quota Hunts -- No hunter quota but a Type 94 permit is required except for landowners hunting on their own land, Sportsman license holders (including Lifetime Sportsman), and hunters who possess a Type 167 permit.

Note: Unit A & B: the bag limit for each county for each non-quota hunt is defined in the Table.

Unit L: a hunter may harvest 3 antlerless deer per day during the regular gun season.

COUNTY	Quota Hunts						Non-Quota Hunts		
	Nov 19- Nov 20	Nov 21- Nov 24	Nov 25- Nov 29	Nov 30- Dec 4	Dec 17- Dec 19	Dec 30- Jan 2	Dec 17 – Dec 23	Dec 24 – Dec 30	Dec 31 – Jan 8
	NUMBER OF PERMITS PER HUNT						NUMBER OF DEER PER HUNT		
Anderson ^{1*}					200	200			
Benton							2	2	
Blount ^{2*}					100	100			
Bradley		500	500						
Carter ³					100				
Chester	100						2	2	2
Claiborne					250				
Clay			200				2		
Crockett									2
Decatur							2	2	2
DeKalb									2
Dyer									2
Franklin ^{**}	1200	1200	1200	1200			3	3	3
Gibson				100			2	2	2
Grainger					250				
Greene ³					100				
Hamblen					100				
Hamilton		500	500						
Hancock					250				
Hardin			400	400			2	2	2
Hawkins ⁴									

See footnotes on page 4

WILDLIFE PROCLAMATIONS

COUNTY	Quota Hunts						Non-Quota Hunts		
	Nov 19- Nov 20	Nov 21- Nov 24	Nov 25- Nov 29	Nov 30- Dec 4	Dec 17- Dec 19	Dec 30- Jan 2	Dec 17 – Dec 23	Dec 24 – Dec 30	Dec 31 – Jan 8
Hawkins ⁵									
Haywood		400	400	400			2	2	2
Henderson							2	2	2
Houston	250						2	2	2
Jackson			200						
Jefferson					250				
Johnson ³					100				
Knox					250				
Lake									2
Lauderdale									2
Loudon					100				
McMinn		500	500						
McNairy				200			2	2	2
Marion			500						
Meigs		500	500						
Obion							2	2	2
Overton				200			2		
Perry								2	2
Rhea		500	500						
Roane		500	500						
Sevier ⁶					100				
Shelby								2	2
Smith**	750	750	750	750			3	3	3
Stewart	200	200	200	200			2	2	2
Sullivan ³					250				
Van Buren			300						
Warren								2	2
White			500						

* - Indicates bag limit of 2 deer per permit for quota hunts.

** - Indicates bag limit of 3 deer per permit for quota hunts.

¹ Anderson County East of Interstate 75 only.

² Blount County West of Highway 411 and east of Highway 129.

³ Excludes Cherokee WMA.

⁴ Hawkins County – Quota hunt on Dec 17-25. 1000 Hunter Quota

⁵ Holston Army Plant - Two quota hunts on Nov. 19 and Nov. 20. 80 Hunter quota.

Two quota hunts on Nov. 26 and Nov 27. 80 Hunter quota.

Bag limit 2 antlerless deer per permit on all hunts

Note: Holston Army Ammunition Plant – additional installation permit fee required if drawn

⁶ Sevier County North of Highway 411.

WILDLIFE PROCLAMATIONS

D. Special Regulations

1. Big Game Tagging – It is unlawful to move, transport, or field dress any big game animal, except for feral hogs, without invalidating and attaching a properly completed temporary kill tag. If additional animals are to be harvested on that calendar day, the hunter is not required to stop hunting and tag the animal until he/she is ready to move, transport, or field dress the animal. All animals harvested must be accompanied by one tagged animal and must be taken together to the nearest big game checking station by the most reasonably direct route where one new temporary kill tag will be issued. The permanent harvest tag is a legal document and must be signed by the hunter. By signing the permanent harvest tag, the hunter is affirming that the information, as it appears on the permanent tag, is correct and valid. The permanent game tag must remain with each carcass until final processing. Persons legally hunting without a license are also required to take any big game animal harvested to a check station. After receiving a temporary harvest tag from checking in their first kill, these persons must comply with all tagging regulations. All big game taken to a taxidermist to be mounted must be accompanied by documentation showing the permanent game tag number, checking station number, and date of kill.

SECTION II. FERAL HOG SEASONS (No hunting with dogs allowed except where indicated.)

Feral hogs are defined as any wild hog found in Tennessee except on Catoosa, South Cherokee, Cove Mtn, and Foothills WMA's. Feral hogs are considered big game but are not required to be tagged or checked in at big game checking stations.

Private lands (Public Hunting Areas are considered private land)

Year round season, except in holdings on Catoosa WMA and South Cherokee where season is open with statewide deer seasons with no dogs.	No limit -either sex
--	----------------------

Publicly owned lands

Open during scheduled white-tailed deer hunts unless otherwise specified.	No limit -either sex
---	----------------------

Big South Fork National River and Recreation Area is also open from Jan. 18-Feb. 28, 2006.	No limit -either sex
--	----------------------

In the following counties dogs may be used for feral hog hunting on the dates indicated7:

Monroe

Gun-Muzzleloader-Archery (Dogs Permitted)	Oct. 10-17, 2005 No limit-Either Sex
--	---

Blount, Cocke (South of I-40), and Sevier

Gun-Muzzleloader-Archery (Dogs Permitted)	Sept. 26-Oct 2, 2005 No limit-Either Sex
--	---

WILDLIFE PROCLAMATIONS

Blount, Cocke, Greene, Monroe, Polk (East of Hwy. 411 & North of Hwy. 64), Sevier, Unicoi, and Washington

Gun-Muzzleloader-Archery (Dogs Permitted)	Nov. 14-15, 2005 No limit-Either Sex
--	---

Blount, Cocke, Monroe, Polk (East of Hwy. 411 & North of Hwy. 64), Sevier

Gun-Muzzleloader-Archery (Dogs Permitted)	Dec. 1-14, 2005 No limit-Either Sex
--	--

SECTION III. BEAR.

The Following Counties Are Open For Bear Hunting⁷:

Blount, Cocke, Greene, Monroe, Sevier, Unicoi, and Washington

Gun-Muzzleloader-Archery (Dogs Permitted)	Nov. 14-15, 2005 1 per year-Either Sex
--	---

Blount, Cocke, Greene, Monroe, Sevier, Unicoi, and Washington

Gun-Muzzleloader-Archery (No Dogs)	Nov. 26-Nov. 27, 2005 1 per year-Either Sex
---------------------------------------	--

Blount, Carter, Cocke, Greene, Johnson, Monroe, Polk (that portion north of Hwy 64), Sevier, Sullivan (that portion east of I-81), Unicoi, and Washington.

Gun-Muzzleloader-Archery (Dogs Permitted)	Dec. 1-14, 2005 1 per year-Either Sex.
--	---

Blount, Cocke (South of I-40), and Sevier

Gun-Muzzleloader-Archery (Dogs Permitted)	Sept. 26-Oct 2, 2005 1 per year-Either Sex.
--	--

Blount and Sevier

Archery Only (No Dogs)	Oct. 8-16, 2005 1 per year-Either Sex.
---------------------------	---

⁷ Dates inclusive.

WILDLIFE PROCLAMATIONS

The Following Counties Are Open For A Bear Dog Training Season:

Cocke, Greene, and Sevier Counties.

Sept. 6-19, 2005. No bears may be taken. No weapons may be possessed. Daylight hours only.

Special Bear Hunting Regulations:

1. The limit of bears for any person participating in the statewide or managed hunts or both shall not exceed one (1) bear per calendar year.
2. Cubs or female bears with cubs at side may not be taken at any time. A cub is defined as any bear weighing seventy-five (75) pounds or less.
3. All harvested bears must be checked out at an official bear checking station designated by TWRA. Bears may be whole or field dressed, but must weigh 75 pounds or greater when checked in.
4. The reproductive sex organs shall remain attached to each bear harvested at least until the bear has been officially checked out at an official bear checking station.

SECTION IV. FALL TURKEY (Shotgun/Archery)

The following counties are open for archery only fall turkey hunting during fall archery only deer seasons. Bag limit for this season is one turkey either-sex. These same counties are open for one quota gun fall turkey hunt on Nov 12-18 with a bag limit of one turkey either-sex per permit with the exception that those counties indicated by an asterisk (*) are open Nov. 12-18 and Dec. 12-16 and have a bag limit of 2 either sex turkeys per permit.

Bedford*	800 Hunter Quota	Hamblen	50 Hunter Quota
Benton	50 Hunter Quota	Hancock	100 Hunter Quota
Cannon*	400 Hunter Quota	Hardeman	50 Hunter Quota
Carroll	50 Hunter Quota	Hardin	50 Hunter Quota
Carter	50 Hunter Quota	Hawkins	150 Hunter Quota
Cheatham*	500 Hunter Quota	Henderson	50 Hunter Quota
Claiborne	100 Hunter Quota	Henry	100 Hunter Quota
Clay	50 Hunter Quota	Hickman*	1000 Hunter Quota
Cocke	100 Hunter Quota	Houston	100 Hunter Quota
Coffee*	400 Hunter Quota	Humphreys	100 Hunter Quota
Davidson	100 Hunter Quota	Jackson	50 Hunter Quota
DeKalb*	500 Hunter Quota	Jefferson	100 Hunter Quota
Dickson*	1500 Hunter Quota	Johnson	50 Hunter Quota
Fayette	100 Hunter Quota	Lawrence*	400 Hunter Quota
Fentress	50 Hunter Quota	Lewis	300 Hunter Quota
Franklin*	600 Hunter Quota	Lincoln*	1200 Hunter Quota
Giles*	1000 Hunter Quota	Macon*	400 Hunter Quota
Grainger	100 Hunter Quota	Madison	100 Hunter Quota
Greene	150 Hunter Quota	Marion*	300 Hunter Quota

WILDLIFE PROCLAMATIONS

Union	50 Hunter Quota	White	100 Hunter Quota
Warren	300 Hunter Quota	Williamson*	500 Hunter Quota
Wayne*	500 Hunter Quota	Wilson*	750 Hunter Quota
Weakley	50 Hunter Quota		

SECTION V. REPEAL OF PRIOR PROCLAMATIONS

This proclamation repeals Proclamations No. 04-10, dated May 20, 2004.

Proclamation No. 05-13 received and recorded this 31st day of May, 2005. (05-39)

WILDLIFE PROCLAMATIONS

TENNESSEE WILDLIFE RESOURCES COMMISSION -1660

PROCLAMATION 05-14 WILDLIFE MANAGEMENT AREAS HUNTING SEASONS, LIMITS AND MISCELLANEOUS REGULATIONS

Pursuant to the authority granted by Tennessee Code Annotated Sections 70-4-107 and 70-5-108, the Tennessee Wildlife Resources Commission hereby proclaims the wildlife management areas hunting seasons, limits and miscellaneous regulations, effective August 1, 2005.

Note: Migratory Bird Season Dates and Limits are pending in lieu of Federal Frameworks.

SECTION 1. GENERAL

A. Hunting Season

1. Management areas open on dates shown and as otherwise indicated.
2. Small game hunting and dog training closed at sunset on the day before and during scheduled big game hunts on the following Wildlife Management Areas, unless special exception indicated: AEDC, Bridgestone/Firestone Centennial Wilderness, Buffalo Springs, Catoosa, Chuck Swan State Forest, Cove Creek, Eagle Creek, Foothills, Laurel Hill, Prentice Cooper State Forest, Reelfoot, the Thief Neck Island Unit of Watts Bar, and Williamsport.
3. Coyote may be taken on any hunt with the weapon legal for that hunt.
4. Season open on groundhog, fox and skunk on all wildlife management areas during any scheduled small game hunt unless special exception is indicated. Crow may be taken on small game hunt days that coincide with statewide crow season.
5. Raccoon and opossum hunting is from sunset of the date shown to sunrise of the next day.
6. Bobcat may be taken on any big game or small game hunt that coincides with the statewide bobcat season, except Oak Ridge WMA.
7. Falconry open with statewide falconry seasons.
8. Small game (except raccoon) and retriever field trials permitted year-round with approval of the Area Manager unless otherwise specified.
9. Raccoon hound field trials permitted Sept. 1-Apr. 30 unless prohibited.
10. Dog training for small game Sept. 1-Mar. 15 unless otherwise indicated. Dog training prohibited on Cove Mountain, Doe Mountain, Eagle Lake Refuge, Fall Creek Falls State Park, Foothills, Ft. Loudoun, Gallatin Steam Plant, Joachim Bible Refuge Unit of Lick Creek Bottoms, Nathan Bedford Forrest State Park, Oak Ridge, Niles Ferry Unit of Tellico Lake, and South Fork Refuge.
11. Spring squirrel season, May 13-June 11, 2006, except closed on the following areas: Cherokee, Cove Mountain, Eagle Lake Refuge, Edgar Evins State Park, Fall Creek Falls State Park, Foothills, Forks of the River, Gallatin Steam Plant, Haley-Jaqueth, Henderson Island, Kingston Refuge, Lick Creek Bottoms, Meeman-Shelby State Park and Natural Area, Nathan Bedford Forrest State Park, Oak Ridge, Paint Rock Refuge, Rankin, Tellico Lake (McGhee-Carson and Niles Ferry Units only), and Yuchi Refuge at Smith Bend. Daily bag limit is 10 squirrels and the possession limit is 20. Hunting with dogs is not allowed, unless exception is noted.
12. Waterfowl hunting from temporary blinds-no blinds or decoys left overnight unless otherwise specified by rule or proclamation.

WILDLIFE PROCLAMATIONS

13. Feral hogs¹ may be taken during any big game hunt on wildlife management areas or refuges, unless otherwise specified. Wild boar seasons are open as indicated.
 14. All game killed or crippled shall be retrieved if possible and retained in the custody of the hunter in the field. No game may be discarded on the premises of the management area.
 15. Persons participating in a sanctioned field trial on a WMA, as authorized by the TWRA, may shoot to retrieve mallards. Mallards used in these trials must be held and released in accordance with all State laws, rules and regulations governing captive wildlife.
 16. The use of ATVs is prohibited on State Parks and state Natural Areas by TDEC rules and regulations.
- B. Bag and Possession Limits
1. One deer may be taken on each managed hunt where a permit is required except as otherwise indicated. Deer taken on buck-only hunts must have antlers a minimum of three inches (3") in length.
 2. Statewide bag and possession limits shall apply unless special exception is indicated.
- C. Miscellaneous Regulations
1. Muzzleloading weapons legal on all Gun-Archery hunts except where indicated.
 2. Possession of shotgun ammunition loaded with more than one solid ball is specifically prohibited while hunting deer, bear or boar.
 3. Dogs allowed for small game hunting. Special regulations apply where indicated.
 4. On all "Young Sportsman Hunts", youths 16 years of age or younger may participate but must be accompanied by an adult, 21 years of age or older, who must remain in a position to take immediate control of the hunting device. Adults cannot hunt except as indicated otherwise. Adults must comply with fluorescent orange regulations, as specified for legal hunters when accompanying young sportsmen on "Young Sportsman Big Game Hunts", except as indicated.
 5. If WMAs are designated as being open with the statewide season, then deer harvested count towards the statewide bag limit. If a specific hunt date and bag limit are listed, the deer are considered bonus deer and are not counted against the statewide bag limit unless otherwise noted. WMA bag limits listed are per hunt.
 6. The placement or depositing of any type of food to feed or attract wildlife on WMAs is prohibited.
 7. Where persons are required to wear fluorescent orange, they must wear on their upper body and head a minimum of 500 square inches of daylight fluorescent orange visible front and back.
 8. Wheelchair bound hunts, zones, or blinds are open to hunters who are totally and permanently confined to a wheelchair as certified by a physician.
 9. On wheelchair bound deer hunts, each wheelchair bound hunter must be accompanied by a non-hunting assistant (age 16 years or older) except on Cordell Hull Refuge and Yuchi Refuge at Smith Bend where the assistant may also participate in hunting. On wheelchair bound waterfowl hunts, each wheelchair bound hunter must be accompanied by at least one, but not more than three assistants (at least one of whom must be age 16 years of age or older), who may also participate in hunting.

¹ Feral hogs are defined as any wild hog found in Tennessee, except on Catoosa, South Cherokee, Cove Mountain and Foothills WMAs.

WILDLIFE PROCLAMATIONS

10. Persons already holding a blind permit may not participate in wheelchair blind permit drawings. If a wheelchair bound blind is not occupied by legal shooting hours, it may be occupied by another wheelchair bound hunter for that day. Applications for wheelchair bound waterfowl blind permits must be received by the appropriate regional office by noon on the 4th Friday in October.

SECTION II. WILDLIFE MANAGEMENT AREAS AND REFUGES – SEASON AND BAG LIMITS

The following areas or units are open to hunting as set out in the statewide seasons and bag limits except as noted:

Alpine Mountain	Jarrell Switch Refuge (10)(11)(17)
Arnold Hollow (17)	Keyes-Harrison
Barkley Unit I (5)(6)(12)(17)(21)(27)	Lick Creek (17)(21)
Barkley Unit II (17)(21)	Long Pond (11)(17)
Bean Switch Refuge (10)(11)(17)(18)(21)	Maple Springs (17)
Beaver Dam Creek (17)	Mingo Swamp (17)
Big Sandy (5)(6)(12)(17)(21)	MTSU (17)
Browntown (17)	Mt. Roosevelt
Camden Unit I (1)(6)(12)(17)(21)(27)	New Hope (17)(21)
Camden Unit II (12)(17)(21)	Normandy (17)
Cedar Hill Swamp (8)(17)	Owl Hollow Mill (17)(31)
Chickasaw State Forest (17)(21)(25)(29)	Pickett State Forest
Cold Creek (17)(30)	Shelton Ferry (17)(32)
Cove Creek (3)(17)(9)	Standing Stone State Forest (2)(15)
Cove Mountain (3)(22)(23)	Tie Camp (17)
Cypress Pond Refuge (10)(11)(17)	Tigrett (1)(17)(21)
Doe Mountain (3)(14)(17)(24)	Tumbleweed (17)
Harmon Creek (17)(21)	Watts Bar (7)(16)
Hick Hill (17)	West Sandy (1)(6)(12)(17)(20) (21)(28)
Hop-In Refuge (10)(11)(17)(18)(21)	White Lake Refuge (10)(11)(17)(18)
Horns Bluff Refuge (8)(10)(17)	White Oak (4)(13)(17)(19)(21)(26)(29)

1. Waterfowl hunting shall close at 3:00 P.M. (CST) each day of the regular statewide waterfowl seasons, except the last day of duck seasons and remaining goose seasons when hunting shall close at sunset.
2. No fox taking.
3. Season closed March 1-August 26, except during turkey and spring squirrel season(s) where applicable. Dog training Sept. 1-Mar.1.
4. Retriever field trials permitted year-round.
5. Hunting of waterfowl during the late duck and goose seasons permitted only on Wednesday, Thursday, Saturday, Sunday, Monday, and the first and last day of each segment of the late duck and goose seasons. During the late duck season, all activities are prohibited in the subimpoundments when waterfowl hunting is closed.
6. All activities are prohibited in the subimpoundments six days prior to the opening day(s) of the statewide duck season.
7. Thief Neck Island Unit – Archery equipment, muzzleloader, and shotguns only for deer hunting. Deer count toward statewide bag. Young Sportsman deer (Shotgun-Muzzleloader-Archery) hunt on Oct. 8-9. No hunter quota. One deer, either sex (bonus deer). Statewide archery season closed on this area during this hunt. Shotguns only for small game.
8. Firearms prohibited for deer hunting.

WILDLIFE PROCLAMATIONS

9. Closed to quail and grouse hunting.
10. Closed to all hunting and dog training Nov. 1-Mar. 1.
11. Closed to waterfowl hunting.
12. Dog training open Sept. 1-Mar. 15, except closed during the late duck season.
13. Waterfowl hunting closes at 1:00 p.m. (CST) during the late duck season(s) and all types of water traffic prohibited after 2:00 p.m.
14. Coyote hunting with dogs prohibited.
15. Buck only bag limit during the muzzleloader seasons. Deer count toward statewide bag. Closed to county special season antlerless hunts.
16. Long Island Unit – Archery equipment, muzzleloader and shotguns only.
17. Squirrel hunting with dogs is permitted during the spring squirrel season.
18. No dove hunting.
19. Archery only deer hunting the second segment of Unit A Gun-Archery season.
20. Hunting restricted to wheelchair hunters and assistants only within the marked wheelchair hunting zone.
21. Young Sportsman deer (Gun-Archery) hunt on Oct. 8-9. No hunter quota. One deer, either sex (bonus deer). Statewide archery season and all small game hunting closed on these areas during this hunt.
22. Wild boar – same as statewide deer seasons. No dogs permitted, except dogs allowed Sept. 26-Oct. 2, Nov. 14-15, Dec. 1-14.
23. Young Sportsman deer-boar (Gun-Archery) hunt Oct. 22-23. No hunter quota. One deer, either sex (bonus deer). Deer count toward statewide bag. Statewide archery season and all small game hunting closed on these areas during this hunt.
24. Young Sportsman deer (Gun-Archery) hunt Oct. 22-23. No hunter quota. One deer, either sex (bonus deer). Deer count toward statewide bag. Statewide archery season and all small game hunting closed on these areas during this hunt.
25. Closed to county special season antlerless hunts. Two antlered deer only during Gun-Muzzleloader-Archery season.
26. All water traffic prohibited six days prior to the opening day(s) of the statewide duck season.
27. Fishing, trapping, and hunting of all species other than waterfowl prohibited in the subimpoundments during the late duck season(s).
28. Waterfowl – wheelchair bound blind provided - first come, first serve.
29. Not open to fall turkey hunting.
30. Regulations same as John Tully WMA
31. Deer season closed after Dec. 16. Squirrel hunting with dogs allowed during spring squirrel season during the spring squirrel season.
32. Deer - Archery equipment only except firearms allowed during first Young Sportsman hunt.
33. During the late duck season, all activities are prohibited in the subimpoundments when waterfowl hunting is closed. Duck seasons 45 days or longer: Hunting of waterfowl during the late duck and goose seasons permitted only on Wednesday, Thursday, Saturday, Sunday, and the first and last day of each segment of the late duck and goose seasons. Duck seasons under 45 days: Hunting of waterfowl during the late duck and goose seasons permitted only on Wednesday, Thursday, Saturday, Sunday, Monday and the first and last day of each segment of the late duck and goose seasons.

WILDLIFE PROCLAMATIONS

AEDC and Woods Reservoir Refuge

Beaver, Dove, Grouse, Quail, Opossum, Rabbit, Raccoon, Snipe, Squirrel, Woodcock

Same as statewide season, except that beaver may be taken only during other small game hunts. Woods Reservoir Refuge – small game hunting closed Dec. 1 – Jan. 31. Squirrel hunting with dogs allowed during spring squirrel season. Shotguns only.

Deer/Turkey (Archery)

One 3-day hunt. Sept. 23-25. Hunter quota 1500. One deer, either sex. One turkey, either sex (bonus deer).

Deer/Turkey (Archery)

One 3-day hunt. Sept. 30-Oct. 2. No hunter quota. One deer, either sex. One turkey, either sex (bonus deer).

Deer (Shotgun-Muzzleloader-Archery)
(Young Sportsman)

One 2-day hunt. Oct. 8-9. No Hunter quota. One deer, either sex (bonus deer).

Deer (Shotgun-Muzzleloader-Archery)

One 2-day hunt. Oct. 12-13. Hunter quota 300. One deer, either sex (bonus deer). Hunting allowed in the National Guard Training Area and Rifle Range Safety Zone only. Scouting days: Oct. 10-11.

Deer (Shotgun-Muzzleloader-Archery)

Four 2-day hunts. Oct. 22-23, 29-30, Nov. 12-13, Nov. 26-27. Hunter quota 750. One deer, either sex (bonus deer).

Deer/Turkey (Archery)

One 3-day hunt. Dec. 2-4. No hunter quota. One deer, either sex (bonus deer). One turkey, either sex. Waterfowl hunting permitted during deer hunt.

Wheelchair Bound Hunter Zone

Wheelchair bound hunters only in the old "Camp Forrest" area of AEDC (north of Wattendorf Hwy., west of Rifle Range Rd., and south of the railroad track) during the following hunts: Nov. 12-13, Nov. 26-27.

Dog Training (Daylight hours only)

Sept. 1- Mar.15

Waterfowl

Hunting from registered blind sites only on Woods Reservoir except during the early duck season; also, Canada goose hunting is allowed outside of blinds upstream from Morris Ferry Bridge except during the duck season. Same as statewide seasons except open on Wednesday, Thursday, Saturday and Sunday of the late duck season and the first and last day of each

WILDLIFE PROCLAMATIONS

segment of the late duck season. Waterfowl hunting allowed on Woods Reservoir during deer hunts when waterfowl season is open. During the September and October waterfowl seasons, hunting is permitted outside of registered blinds on Woods Reservoir except 150 yards out from the bank beginning at the Pumping Station and going west to Arnold Village slough and beginning at the Famcamp slough and going west to the Rowlands Creek causeway. During the youth waterfowl hunting season, hunting on Woods Reservoir allowed outside blinds upstream from Morris Ferry Bridge. Downstream from Morris Ferry registered blind sites only.

Closure

Public use of Woods Reservoir Refuge, including all forms of trespass, is prohibited Dec. 1-Jan.31, except as otherwise indicated.

ATVs and Motorcycles

ATVs and motorcycles are prohibited on AEDC except ATVs can be used only in the Rifle Range Safety Zone during the Oct. 12-13 hunt and the Oct. 10-11 Rifle Range scouting days. ATVs are also allowed for use by wheelchair bound hunters hunting in the wheelchair bound hunt zone during the Nov. 12-13 and Nov. 26-27 hunts.

Unauthorized Digging

Unauthorized Digging on Arnold Air Force Base is prohibited for safety and legal reasons. Buried and unexploded ordnance (UXO) could be encountered and unauthorized ground disturbance is a violation of Federal law.

Bark Camp Barrens

Dove, Quail, Rabbit, Snipe, Squirrel
Woodcock, Opossum, Raccoon, Deer,
Waterfowl

Same as statewide seasons.
Squirrel hunting with dogs allowed during the spring squirrel season. All deer hunting closes after Dec. 16. Deer count toward statewide bag.

Crow

July – August. Fridays, Saturdays, and Sunday only.

Black Bayou Refuge

Rabbit (Quota Hunt)

Four 1-day hunts. Oct. 8, 9, 15, 16. Six parties per hunt. Six hunters per party. Six dogs per

WILDLIFE PROCLAMATIONS

	party. Five rabbits per hunter. Nontoxic shot approved by the U.S. Fish & Wildlife Service only. Sign-up for hunt will be at the Reelfoot Lake WMA office parking lot at Reelfoot Lake, Sept. 10, between the hours of 9:00 am and 12:00 noon. A drawing for permits will be held immediately following the sign-up period.
Dove, Opossum, Quail, Rabbit, Raccoon, Snipe, Squirrel, Woodcock	Same as statewide seasons, except closed to all hunting after Nov. 14. Nontoxic shot approved by the U.S. Fish & Wildlife Service only. Squirrel hunting with dogs allowed during spring squirrel season.
Deer (Archery)	Two hunts. Sept. 24-Oct. 28, Oct. 31-Nov. 13. No hunter quota. Three deer, either sex per segment (bonus deer). Small game hunting allowed during deer hunts.
Deer (Young Sportsman)	One 2-day hunt. Oct. 29-30. No hunter quota. One deer, either sex. Deer count toward statewide bag.
Dog Training	Sept. 1- Nov. 13.
Bogota	
Special Dove (Young Sportsman)	Sept. 3. Noon until sunset. Each Young Sportsman must be accompanied by a non-hunting adult
Dove, Opossum, Raccoon, Squirrel, Deer	Same as statewide except dove opens Sept. 4 (designated fields only). All hunting, except waterfowl closes Nov. 1. Deer count toward statewide bag.
Waterfowl (Pool 1 only)	Same as statewide season except hunting of waterfowl during the late duck season permitted only on Friday, Saturday, Sunday, and the first and last day of each segment of the late duck season. All hunting shall cease at 3:00 p.m. (CST) each day, except the last day of the season when hunting shall close at sunset.
Dog Training	Sept. 1-Oct. 31

Bridgestone/Firestone Centennial Wilderness

No ATVs, motorcycles, or horseback riding permitted.

WILDLIFE PROCLAMATIONS

Dove (Young Sportsman)	Sept. 3. Each Young Sportsman must be accompanied by a non-hunting adult. Hunting starts at noon.
Dove	Sept. 5, and the remainder of the statewide season.
Crow, Grouse, Rabbit, Snipe, Squirrel Waterfowl, Woodcock	Same as statewide seasons.
Opossum, Raccoon	Same as statewide season, except hunting will be limited to Friday and Saturday nights only. All hunting ends Jan. 1.
Deer (Archery)	Five 3-day hunts. No hunter quota. Sept 24-26, Sept. 27-29, Sept. 30-Oct. 2, Oct. 3-5, 6-8. One deer, either sex (bonus deer).
Deer (Archery)	One 5-day hunt. Dec 12-16. No hunter quota. One deer, either sex (bonus deer).
Deer (Gun-Archery)(Young Sportsman)	One two-day hunt. Oct. 29-30. No hunter quota. One deer, either sex (bonus deer).
Deer (Gun-Archery)	One 9-day hunt. Nov. 19-27. No hunter quota. Two deer, buck only. Deer count toward statewide bag.
Dog Training	Sept. 1-Mar. 15

Buffalo Springs

Waterfall parking area closed one hour after sunset until one hour before sunrise. Use or possession of alcohol is prohibited in the waterfall area. Small game hunters (except waterfowl) must wear fluorescent orange during the big game gun hunts.

Dove	Sept. 1, 3, 5 noon until sunset only. Open every day thereafter during the statewide dove season. Hunter quota 55. Staked positions only. A random drawing will be held at 11 a.m. on Sept. 1 and 3. Otherwise, first come, first served
Deer, Grouse, Opossum, Quail, Rabbit, Raccoon, Snipe, Squirrel, Turkey, Waterfowl, Woodcock	Same as statewide seasons. Squirrel hunting with dogs allowed during spring squirrel season. Deer count toward statewide bag.

WILDLIFE PROCLAMATIONS

Catoosa

Dove, Grouse, Quail, Rabbit, Snipe, Squirrel, Waterfowl, Woodcock	Same as statewide seasons, except walk-in hunting only from Feb. 1-28.
Opossum, Raccoon	Sunset Nov. 4 to Sunrise Dec. 30.
Deer/Boar (Archery)	Three 3-day hunts. Oct. 15-17, 18-20, 21-23. No hunter quota. Area checking stations operated. Entire area open. Two deer, no more than one antlered (bonus deer). Boar – no limit, either sex.
Deer/Boar (Muzzleloader-Archery)	One 3-day hunt. Nov. 17-19. Station quota: Genesis 1,000; Bicolor 1,000. One deer, buck only (bonus deer). Boar – no limit, either sex.
Deer/Boar (Gun-Archery)	Two 3-day hunts. Nov. 10-12, Dec. 8-10. Station quota: Genesis 1,250; Bicolor 1,250. One deer, buck only (bonus deer). Boar - no limit, either sex.
Deer/Boar (Young Sportsman)(Gun-Archery)	One 2-day hunt. Oct. 29-30. Station quota: Genesis 400; Bicolor 400. Two deer, no more than one antlered (bonus deer). Boar – no limit, either sex.
Deer/Boar (Gun-Archery)	One 3-day hunt. Dec. 15-17. No hunter quota. Entire area open. One deer, buck only (bonus deer). Boar – no limit, either sex.
Boar (Gun-Archery)(Dogs Permitted)	One 3-day hunt. Jan. 5-7. Station quota: Genesis 200; Bicolor 200. Entire area open. Boar - no limit, either sex.
Bullfrog Apr. 1- Sept. 1. No hunting during turkey hunts.	
Special Regulations:	Buck deer must have a minimum of 4 points on one antler on all hunts. Points must be at least 1 inch or longer. Catoosa WMA will be closed to all users Feb. 1 – last Friday in March, except walk-in hunters will be allowed Feb. 1 – last day of Feb. Guides prohibited on all hunts. ATVs and motorized bikes are permitted only by individuals possessing the appropriate licenses and permits from the 4 th Saturday in August thru the Spring Squirrel season.
Dog Training (Daylight hours only)	Sept. 1 – Jan. 31.

WILDLIFE PROCLAMATIONS

Cheatham

Dove, Quail, Rabbit, Snipe, Squirrel, Deer
Raccoon, Opossum, Woodcock

Same as statewide seasons except deer hunting closes after Dec. 25. Squirrel hunting with dogs allowed during spring squirrel season. Deer count toward statewide bag.

Turkey (fall)

Nov. 12-18, Hunter quota 150, Two either sex

Firing Range

Open as posted. Automatic weapons prohibited.

Archery Range

Open daily. Field points only.

Dog Training (Daylight Hours Only)

Sept. 1 –Mar. 15.

Cheatham Lake

Deer, Opossum, Quail, Rabbit, Raccoon, Snipe
Squirrel, Turkey, Waterfowl, Woodcock

Same as statewide seasons on Sycamore Creek upstream from railroad trestle, Harpeth River upstream from Highway 49, and on Johnson Creek upstream from Johnson Creek Bridge. Deer count toward statewide bag.

Hunting on remainder of Cheatham Lake WMA same as statewide season except during the late duck season when hunting is open only on Wednesday, Thursday, Saturday, Sunday, and the first and the last day of each segment of the late statewide duck season. Waterfowl hunting is permitted only from registered blind sites and from staked temporary blind sites during the late duck season.

Hunting on Harpeth Island, Marks Creek, and Bluff Creek wade-in areas is not restricted to registered or staked temporary sites. Night hunting, trapping, and fishing prohibited in waterfowl impoundments during the waterfowl season. The sub-impoundment units as posted are closed to all types of activity six days prior to the opening of the first segment of the late duck season.

Squirrel hunting with dogs allowed during spring squirrel season.

Waterfowl (Wheelchair-bound only blind site)

Applications must be received by TWRA Region II by noon on the 4th Friday in October. Persons holding a permit for another blind are not eligible.

WILDLIFE PROCLAMATIONS

Beaver	May be taken during any hunt.
Dove	Same as statewide. Hunting allowed from designated fields only.
Dog Training	Sept. 1-Mar. 15, except closed during duck seasons.

Cheatham Lake – Pardue Pond Refuge and Dyson Ditch Refuge

Deer (Archery)	Sept. 24- Oct. 9. No hunter quota. Bag limit same as statewide. Deer count toward statewide bag.
Turkey (fall)	Nov. 12-18, Hunter quota 150, Two either sex
Dog Training	Sept. 1- Mar.15, except closed Oct. 15-Feb.14.
Closure	Public use, including all forms of trespass, is prohibited from Oct. 15 through Feb. 14, except as otherwise indicated.

Cherokee²

Horseback riding on properties owned by the U.S. Forest Service shall be the same as U.S. Forest Service regulations. On those properties owned or leased by the TWRA, horseback riding is only allowed upon roads opened for vehicle travel: no riding off roads into openings, fields, trails, or through streams.

North Cherokee	That portion of the Cherokee WMA lying north of the Great Smoky Mountains National Park.
South Cherokee	That portion of the Cherokee WMA lying south of the Great Smoky Mountains National Park.
Ocoee Unit	That portion of the South Cherokee lying south of the Hiwassee River.
Tellico Unit	That portion of the South Cherokee lying north of the Hiwassee River, and south of the Little Tennessee River.

² Bobcat hunting with dogs prohibited. Dog training prohibited, except for Bear Dog Training Season in Cocke and Greene counties. The use of and/or possession of any tracking device for dogs from March 1 to August 31 is illegal. Hunting of coyotes with dogs prohibited

WILDLIFE PROCLAMATIONS

North Cherokee

On property that is owned or leased by TWRA, ATV and OHV operation is prohibited at all times at any location inside the boundaries of these properties.

Dove, Grouse, Quail, Rabbit, Snipe, Squirrel	Same as statewide seasons. ³ Small game hunting (shotguns only) allowed during all big game hunts, but small game hunters (except raccoon and opossum hunters between sunset and sunrise) must wear 500 sq. in. of fluorescent orange during big game hunts.
Deer, Turkey	Same as statewide seasons, except closed to special county antlerless hunts
Opossum, Raccoon	Same as statewide season, except the season is closed Nov. 14-15, Nov. 26-27, and Dec. 1-14 in all Bear Reserves.
Bear Dog Training Season (Cocke and Greene Counties only)	Sept.6-19. No bears may be harvested. No weapons may be possessed. Daylight hours only. No training in bear reserves.
Bear	Same as statewide season. Feral hog hunting closed in bear reserves during bear season.

South Cherokee⁴

Special Weapons Regulations:

1. .22 caliber short, long and long rifle are the only legal weapons on a raccoon hunt.
2. It is illegal to possess firearms with any breed of dog other than pointing breeds during daylight hours, excluding Bear and Boar season, except as provided.

Dove, Grouse, Quail, Rabbit, Snipe, Squirrel Waterfowl, Woodcock	Same as statewide seasons, except, no season shall open prior to Oct. 9. Small game hunting closed at sunset the day before and during big game hunts. When specified portions of the Cherokee are hunted, this closure applies only to those specific areas and to the Tellico Bear Reserve during bear hunts. Dogs permitted for squirrel hunting west of Hwy. 68 and north of Ocoee River Jan.1-Feb. 28.
---	---

⁴ No feral hog hunting on South Cherokee WMA; boar hunting is allowed as indicated.

WILDLIFE PROCLAMATIONS

Ocoee Unit

Opossum, Raccoon	Same as statewide season, except closed at sunset the day before and during big game hunts. Ocoee Bear Reserve sunset Dec. 19-Jan. 14.
Deer/Boar (Archery)	One 9-day hunt. Sept. 17-25. No hunter quota. One deer, either sex (bonus deer). One boar, either sex.
Deer/Boar (Gun-Archery)(Young Sportsman)	One 2-day hunt. Oct. 8-9, south of Ocoee River only. No hunter quota. One deer, either sex (bonus deer). One boar, either sex.
Deer/Boar (Gun-Archery)(Young Sportsman)	One 2-day hunt. Oct. 22-23. No hunter quota. One deer, either sex (bonus deer). One boar, either sex.
Deer/Boar (Muzzleloader-Archery)	One 3-day hunt. Oct. 28-30. No hunter quota. One deer, buck only (bonus deer). One boar, either sex.
Deer/Boar (Gun-Archery)	One 3-day hunt. Nov. 4-6. No hunter quota. One deer, buck only (bonus deer). One boar, either sex.
Deer/Boar (Gun-Archery)	One 9-day hunt. Nov. 19-27. No hunter quota. Two deer, buck only (bonus deer). One boar, either sex.
Boar (Gun-Archery)(Dogs Permitted)	Two 4-day hunts. Oct. 10-13, 14-17. No hunter quota. One boar, either sex. Between Ocoee River and Hiwassee River.
Bear/Boar (Gun-Archery)(Dogs Permitted)	One 2-day hunt. Nov 14-15. No hunter quota. One bear, either sex; one boar, either sex. Between Ocoee River and Hiwassee River.
Bear/Boar (Gun-Archery)(Dogs Permitted)	One 14-day hunt. Dec. 1-14. No hunter quota. One bear per person per year. One boar either sex. Between Ocoee River and Hiwassee River.
Deer/Boar (Gun-Archery)	One 10-day hunt. Nov. 28 – Dec 7. No hunter quota. Two deer, buck only (bonus deer). One boar, either sex. South of Ocoee River only.

WILDLIFE PROCLAMATIONS

Tellico Unit

Bear reserves are closed to all big game hunting when the bear season is open on the Tellico Unit.

Opossum, Raccoon (Raccoon hunters must wear fluorescent orange during bear season)	Oct. 31-Nov. 13, Dec. 1-14, Dec. 19-Jan. 14. Tellico bear reserve sunset Dec. 19-Jan. 14 only.
Deer/Boar (Archery)	One 9-day hunt. Sept. 17-25. No hunter quota. Two deer, either sex (bonus deer). One boar either sex.
Deer/Boar (Gun-Archery)	One 9-day hunt. Nov. 19-27. No hunter quota. Two deer, buck only (bonus deer). One boar either sex.
Deer/Boar (Muzzleloader-Archery)	One 3-day hunt. Sept. 30-Oct. 2. No hunter quota. One deer, buck only (bonus deer). One boar either sex.
Deer/Boar/Bear (Muzzleloader-Archery)	One 3-day hunt. Dec. 16-18. No hunter quota. One deer, buck only (bonus deer). One boar either sex. One bear, either sex. Hunting confined to that area outside of the Tellico Bear Reserve.
Deer/Boar/Bear (Young Sportsman)(Gun-Archery)	One 2-day hunt. Oct. 29-30. No hunter quota. One deer, either sex (bonus deer). One boar either sex. One bear, either sex. Hunting confined to that area outside of the Tellico Bear Reserve.
Boar (Gun-Archery)(Dogs Permitted)	Two 4-day hunts. Oct. 10-13, 14-17. No hunter quota. One boar, either sex. Hunting confined to that area outside the Tellico Bear Reserve and the party dog area.
Bear/Boar (Gun-Archery)(Dogs Permitted)	One 2-day hunt. Nov. 14-15. No hunter quota. One bear, either sex; one boar, either sex. Hunting confined to that area outside the Tellico Bear Reserve and the party dog area.
Bear/Boar (Gun-Archery)(Dogs Permitted)	One 14-day hunt. Dec. 1-14. No hunter quota. One bear per person per season. One boar, either sex. Hunting confined to that area outside the Tellico Bear Reserve and the party dog area.
Deer/Boar (Gun-Archery) (No Dogs Allowed)	One 3-day hunt. Oct. 21-23. No hunter quota. One deer, either sex (bonus deer). One boar, either sex. Hunting confined to the Tellico Bear Refuge.

WILDLIFE PROCLAMATIONS

Boar (Gun-Archery)
(Party Dog Hunts)

One 3-day hunt. Oct. 21-23. One boar either sex. One party permitted in each of the following areas: Upper Tellico, Lower Tellico, Upper Bald River, Lower Bald River.

Bear/Boar (Gun-Archery)
(Party Dog Hunts)

Two 2-day hunts. Oct. 6-7, Nov. 29-30. One bear per person per season. One boar, either sex. One party permitted in each of the following areas: Upper Tellico, Lower Tellico, Upper Bald River, Lower Bald River.

Chickamauga

(Soddy Creek, Sale Creek, Mud Creek, New Bethal, Moon Island, Cottonport, Washington Ferry, Goodfield Creek, Gillespie Bend, Agency Creek, Sugar Creek, South Mouse Creek Units)

Deer, Dove, Furbearers, Quail, Rabbit, Snipe
Squirrel, Waterfowl, Woodcock

Same as statewide hunting and trapping seasons. No waterfowl hunters allowed on Units from two hours after legal shooting hours have ended until 4:00 a.m. the following day during the late duck season(s). Deer count toward statewide bag.

(Candies Creek, Rogers Creek, Yellow Creek, Johnson Bottoms Units)

Deer, Dove, Furbearers, Quail, Rabbit, Snipe
Squirrel, Waterfowl, Woodcock

Same as statewide hunting and trapping except closed to non-waterfowl species during the late duck season. Waterfowl hunting permitted only on Tuesday, Thursday, Saturday and Sunday and the opening and closing day of the duck season. No trapping during the duck season. During the late duck season all hunting ceases at 12:00 p.m. each day. All activities are prohibited on units from two hours after the end of the waterfowl hunting hours until 4:00 a.m. the following day during the late duck season. Deer count toward statewide bag.

Dog Training

Sept. 1- Mar. 15, except closed during late duck season.

Chuck Swan State Forest

1. Guides, deer driving, loud noises, and harassment on all deer hunts, and entering the wildlife management area from Norris Lake during the deer and turkey hunts prohibited.
2. Horses, ATVs, ORVs, Bicycles, and Non-licensed Passenger Vehicles and Motorcycles are prohibited on the Main Forest Road. The Main Forest Road is defined as the road beginning at the big game

WILDLIFE PROCLAMATIONS

checking station and ending at the intersection of the Back Valley, Forks of the River, and Big Loop roads. A licensed vehicle is defined as a vehicle that is tagged, registered, and insured and is legal to operate on County, State, and Federal highways.

3. Speed limit 25 mph.

Dove, Rabbit, Squirrel, Waterfowl	Same as statewide seasons.
Raccoon	Six 1-day hunts. Nov. 8, 10, 12, 14, 16, 18 Hunters must check out by 2:00 A.M. All raccoons must be checked out. One raccoon per party. Party defined as all the occupants of a single vehicle.
Deer, Turkey (Archery)	Two 2-day hunts. Oct. 14-15, 21-22. Hunter quota 800. One deer, either sex (bonus deer). One turkey, either sex.
Deer (Gun-Archery)(Young Sportsman)	One 2-day hunt. Oct. 29-30. Hunter quota 200. One deer, either sex. Deer count towards statewide bag limit.
Deer (Gun-Archery)	Two 2-day hunts. Dec. 2-3, 9-10. Hunter quota 750. One deer, buck only (bonus deer).
Deer (Muzzleloader-Archery)	One 2-day hunt. Nov. 25-26. Hunter quota 750. One deer, buck only (bonus deer).
Turkey (Shotgun-Archery)	Three 2-day hunts. Sept. 30-Oct. 1, Oct. 7-8, Dec 16-17. Hunter quota 125. One turkey, either sex.
Dog Training (Daylight hours only) Pointing breed dogs prohibited	Sept. 1-Mar. 15.

Cordell Hull

Includes all property posted and painted with Corps of Engineers and/or TWRA WMA signs.

Deer, Small Game, Turkey, Waterfowl	Same as statewide seasons except deer hunting ends Dec. 16. Deer count toward statewide bag. Wheelchair bound hunter zone open to wheelchair bound hunters only. Deer bag limit is either-sex (bonus deer) in the wheelchair bound zone on Nov. 19-20.
Wheelchair-Bound Hunter Zone	That area in the old "Corps of Engineers Roaring River Campground" area of Cordell Hull WMA (north of Hwy. 135, north of Roaring River, south and east of Hwy. 85, and west of old Roaring River Iron Bridge Road.

WILDLIFE PROCLAMATIONS

Cordell Hull Refuge

Squirrel Aug. 27-Nov. 11 and the spring squirrel season.

Dove	Sept. 1-11, noon until sunset
Canada Goose	Sept. 1-15.
Wood duck/teal	Same as the September Wood duck/Teal season.
Deer (Archery)	Sept. 26-Oct. 30. Bag limit same as Unit A archery season. Deer count toward statewide bag.
Deer (Archery)(Wheelchair Bound Only)	Sept. 24-25. No hunter quota. One deer, either sex (bonus deer).
Deer (Gun-Archery)(Wheelchair Bound Only)	Nov. 5-6. No hunter quota. One deer, either sex (bonus deer).
Closure	Public use, including all forms of trespass, is prohibited from Nov. 15-Mar. 1, except as otherwise indicated. Public entry and fishing permitted while on the main river channel passing through the refuge.
Dog Training	Sept. 1-Nov. 14, daylight hours only.

Eagle Creek

Dove, Opossum, Quail, Rabbit, Raccoon Snipe, Squirrel, Woodcock	Same as statewide seasons. Squirrel hunting with dogs allowed during spring squirrel season.
Deer (Archery)	One 21-day hunt (split into two segments). Sept. 24-Oct. 7, Oct. 10-16. No hunter quota. Two deer, either sex (bonus deer). No area checking station operated.
Turkey (Archery)	Open during all archery only seasons. No hunter quota. One turkey, either sex.
Deer (Gun-Archery)(Young Sportsman)	One 2-day hunt. Oct. 8-9. No hunter quota. One deer, either sex (bonus deer).
Deer (Gun-Archery) (Wheelchair Bound only)	One 1-day hunt. Oct. 22. No hunter quota. One deer, either sex (bonus deer). "Wheelchair Bound Hunt Zone" only.

WILDLIFE PROCLAMATIONS

Wheelchair Bound Hunter Zone	Wheelchair bound hunters only on roads #2 through #10 on Oct. 22.
Deer (Gun-Archery)	Four 4-day hunts. Oct. 27-30, Nov. 10-13, Nov. 24-27, Dec. 1-4. No hunter quota. One deer, either sex (bonus deer).
Fall Turkey	One 3-day hunt. Dec. 9-11. Hunter quota 200. Two turkey, either sex.
Eagle Lake Refuge	
Dove, Opossum, Quail, Rabbit, Raccoon, Snipe, Squirrel, Woodcock	Open Mondays, Wednesdays and Saturdays within statewide seasons
Deer (Archery)	Open Mondays, Wednesdays and Saturdays within first segment of Unit A archery season Sept. 24-Oct. 28. Deer count toward statewide bag. Small game hunting allowed during deer season.
Closure	Eagle Lake Refuge is closed to all hunting Nov. 1- Mar. 1. Waterfowl hunting prohibited. Non-toxic shot approved by the U.S. Fish & Wildlife Service required for small game hunting. Access to the south end of Shelby Forest WMA through Eagle Lake Refuge will be allowed during hunting seasons.
Edgar Evins State Park	
Deer, Opossum, Quail, Rabbit, Raccoon, Turkey	Same as statewide seasons. Deer count toward statewide bag.
Deer (Safety Zone)(Archery)	Oct. 18-19. 200 hunter quota. Bag limit two deer, either sex (bonus deer). Sign up for hand held drawing will be 8 a.m. to noon on Sept. 14 at Park Office.
Ernest Rice, Sr.	
Dove, Opossum, Quail, Rabbit, Raccoon, Snipe, Squirrel, Waterfowl, Woodcock	Same as statewide seasons except closed Dec 17-18. Squirrel hunting with dogs allowed during spring squirrel season.
Deer (Archery)	Sept. 24-Oct. 28. No hunter quota. Bag limit two deer, either sex. Bucks must be spike or nine antler points or better. Deer count toward statewide bag.

WILDLIFE PROCLAMATIONS

Deer (Archery)	Dec. 24-Jan. 8. No hunter quota. Bag limit two deer-either sex. Bucks must be spike or nine antler points or better (bonus deer).
Deer (Gun-Muzzleloader-Archery)	One 2-day hunt.. Dec. 17-18. No hunter quota. Bag limit one deer, antlered only. Bucks must be spike or nine antler points or better. Deer count toward statewide bag.
Deer (Gun-Archery)(Young Sportsman)	One 2-day hunt Oct. 29-30. No hunter quota. Deer count toward statewide bag.

Fall Creek Falls State Park

Vehicle parking restricted to designated parking areas only during the hunting season. No parking allowed at all on roadside grass. All deer hunters must sign register at horse stables before hunting.

Grouse, Squirrel	Dec. 1-last day in February. Shotguns only.
Deer (Archery)	One 3-day hunt. Nov. 12-14. Hunter quota 300. Two deer, no more than one antlered (bonus deer).
Deer (Archery)	One 6-day hunt. Nov. 15-20. No hunter quota. Two deer, no more than one antlered (bonus deer).

Flintville Hatchery

Dove, Quail, Rabbit, Snipe, Squirrel, Woodcock	Same as statewide seasons. Squirrel hunting with dogs allowed during spring squirrel season.
Deer	Same as statewide deer season. Archery equipment only. Deer count toward statewide bag.
Deer (Young Sportsman)(Gun-Archery)	One 2-day hunt. Oct. 29-30. No hunter quota. One deer, either sex. Deer count toward statewide bag.
Dog Training (Daylight hours only)	Sept. 1- Mar. 15.

Foothills

Motorized vehicles and horseback riding prohibited. All small game hunters must wear 500 square inches of blaze orange during big game seasons. Small game hunters must use shotguns only during big game seasons. The use of and/or possession of any tracking device for dogs from March 1 to August 31 is illegal.

WILDLIFE PROCLAMATIONS

Dove, Grouse, Quail, Rabbit, Snipe, Squirrel Same as statewide seasons.
Waterfowl, Woodcock

Opossum, Raccoon	Dec. 17-Feb 15.
Deer/Boar (No dogs permitted)	Same as statewide deer seasons, except closed during Oct. 22-23 Young Sportsman hunt. Deer count toward statewide bag.
Bear/Boar (Gun-Archery)(No dogs permitted)	One 2-day hunt. Nov. 26-27. No hunter quota. Bag limit same as statewide.
Bear/Boar (Gun-Archery)(Dogs permitted)	Sept. 26-Oct. 2, Nov. 14-15, Dec. 1-14. No hunter quota. Bag limit same as statewide.
Deer/Boar (Gun-Archery)(Young Sportsman)	One 2-day hunt. Oct. 22-23. No hunter quota. One deer, either sex. Deer count toward statewide bag. One boar, either sex.

Forks of the River

Area closed one hour after sunset to one hour before sunrise except for raccoon and opossum hunters and scheduled events. Bicycles are restricted to greenway trail from Sept. 1- Feb. 29. Paintball guns and accessories prohibited. All animals accompanied by a non-hunting person are required to be leashed.

Dove	Sept. 1, 3, and every day thereafter during the statewide dove season. Hunting from noon to sunset only on Sept. 1, 3.
Deer, Quail, Rabbit, Snipe, Squirrel, Waterfowl, Woodcock	Same as statewide seasons. Deer count toward statewide bag.
Opossum, Raccoon	Nov. 4-16.
Crow	Sept. 3- Feb. 28 (Fridays, Saturdays and Sundays only).
Arms and Ammunition	Shotguns and Archery equipment only.

Fort Loudoun

Waterfowl

Same as statewide seasons, except open only on Monday, Wednesday, and Friday, one half hour before sunrise until noon. Nontoxic shot, size BBB or smaller required.

WILDLIFE PROCLAMATIONS

Fourth Fractional Township

ATVs and motorcycles prohibited.

Dove, Grouse, Quail, Rabbit, Snipe,
Squirrel, Woodcock

Same as statewide seasons. Small game hunting with shotguns only with No. 6 shot or smaller. Beagles and pointing breeds only.

Deer

Same as statewide seasons, archery tackle only. Deer count toward statewide bag.

Bear (Archery)

Nov. 24-Dec. 7. No hunter quota. One bear, either sex.

Dog training

Year-round, beagles and pointing breeds only.

Gallatin Steam Plant

Deer/Turkey (Archery Only)

Four 3-day hunts. Sept. 23-25, Oct. 7-9, 21-23, Dec. 2-4. Hunter quota 50 per hunt. Two deer, either sex (bonus deer). One turkey, either sex. Parking in designated areas. No camping.

C.M. Gooch

Dove, Opossum, Quail, Rabbit, Raccoon
Snipe, Squirrel, Woodcock

Same as statewide seasons, except Units "A" and "E" are closed during the waterfowl seasons and are closed to all activities six days prior to the first opening of the late duck season. Squirrel hunting with dogs allowed during spring squirrel season.

Waterfowl

Same as statewide season except Gooch waterfowl hunting closes at 3:00 p.m. on Units "A" and "E". Waterfowl hunting on the last day of each segment of the duck and remaining goose seasons shall close at sunset. Fishing and trapping is prohibited in Units "A" and "E" during the waterfowl season.

Deer

Same as statewide season, except closed six (6) days prior to and during statewide waterfowl seasons on Gooch Unit A and Gooch Unit E. and closed to statewide archery hunt during the Young Sportsman deer hunt on Oct. 8-9. Deer count toward statewide bag.

WILDLIFE PROCLAMATIONS

Deer (Gun-Archery)(Young Sportsman)

One 2-day hunt. Oct. 8-9. No hunter quota. One deer, either sex (bonus deer).

Haley-Jaqueth

Dog Training (daylight hours only)

Sept. 1- Mar. 15.

Haynes Bottom

Opossum, Quail, Rabbit, Raccoon, Snipe
Squirrel, Turkey, Waterfowl, Woodcock

Same as statewide seasons except during the late duck season when hunting is open only on Wednesday, Thursday, Saturday, Sunday, and the first and last day of each segment of the late statewide duck season. Quail hunting Wednesday and Saturday only. Rabbit hunting Thursday and Sunday only. Waterfowl hunting permitted only from registered blind sites beginning with the first day of the late duck season. Night hunting, trapping, dog training, and fishing prohibited in the waterfowl impoundments during waterfowl season. Participating waterfowl hunters only in the bottoms during waterfowl seasons. Squirrel hunting with dogs allowed during spring squirrel season.

Dove

Same as statewide season, on designated fields only.

Deer

Same as statewide seasons, except all deer hunting closed after Dec. 16. Deer count toward statewide bag.

Crow

July – August. Fridays, Saturdays, and Sundays only.

Henderson Island Refuge

Horses prohibited.

Dove

Sept. 1, 3, 5, 7, 14. Hunting from noon to sunset only.

Squirrel Sept. 1-9, Oct. 10-30, Feb. 2-28.

Quail, Rabbit

Feb. 2-28.

Deer (Muzzleloader-Shotgun)(Young

Three 1-day hunts. Sept. 10, 17, Nov. 5.

WILDLIFE PROCLAMATIONS

Sportsman)	Hunter quota 20. One deer, either sex (bonus deer). Sign up for drawing will be held at the Jefferson County courthouse in Dandridge between 9:00 a.m. and 11:00 a.m. on Aug. 6. Youth must be present at sign up and drawing.
Deer/Turkey (Archery)	Sept. 24-Oct. 9. Bag limit same as statewide. Deer count toward statewide bag.
Canada Goose	Sept. 2, 4-9. Bag limit 5 geese per day.
Raccoon	Nov 4-12.
Dog Training	Feb. 2-28.
Closure Public use, including all forms of trespass, is	prohibited from Nov. 16 through Feb. 1, except as otherwise indicated. Public entry and fishing permitted while on the main river channel passing through the refuge.
Hickory Flats	
Dove, Quail, Rabbit, Snipe, Squirrel Woodcock, Opossum, Raccoon, Deer	Same as statewide seasons. Squirrel hunting with dogs allowed during the spring squirrel season. All deer hunting closes after Dec. 16.
Crow	July – August. Fridays, Saturdays, and Sunday only.
Hiwassee Refuge (Nontoxic shot required for small game hunting)	
Dove	Sept. 1, 3. Noon to sunset only. No access permitted by boat.
Squirrel	To include all of the Hiwassee Refuge except Hiwassee Island. Aug. 27-Sept. 10. Spring squirrel season same as statewide, dogs prohibited.
Canada Goose	Sept. 1-15. No goose hunters allowed on refuge from two hours after shooting hours have ended until 4:00 a.m. the following day.
Wood duck/teal	Same as Sept. Wood duck/Teal season. No duck hunters allowed on the refuge from two hours after shooting hours have ended until 4:00 a.m. the following day.

WILDLIFE PROCLAMATIONS

Deer (Archery)	One 3-day hunt. Sept. 24-26. Hunter quota 250. Two deer, either sex (bonus deer).
Deer (Archery)	One 3-day hunt. Oct. 14-16. No hunter quota. Two deer, either sex (bonus deer).
Deer (Muzzleloader)	One 3-day hunt. Oct. 28-30. Hunter quota 200. Two deer, either sex (bonus deer).
Deer (Shotgun-Muzzleloader)(Young Sportsman)	One 2-day hunt. Sept. 17-18. Hunter quota 100. Two deer, either sex (bonus deer).
Retriever (Field Trials)	Pre-approved by area manager at least 30 days in advance of trial dates.
Closure	Refuge is closed to all forms of public use, including all forms of trespass, from Nov. 1 through last day of February. Public entry and fishing is permitted while on the main river channel passing through the refuge.
Dog Training (Daylight hours only)	Sept. 1-Oct. 14, Mar. 1-15.

Holly Fork

Dove	Two 1-day hunts Sept, 10 and Sept. 17. Hunting from noon to sunset only. Wheelchair-bound hunting only, with one hunting assistant, from staked positions, first come first serve.
Deer (Muzzleloader)	Nov. 5-11. Four hunting stations are open for wheelchair-bound hunters and special youth populations by reservation. Reservations for a hunting station will be taken on a first-come first-served basis by calling the TWRA Region I Office on or after the first Monday in October or prior to the day of hunting. Wheelchair-bound hunters must be accompanied by a non-hunting assistant. Youth special populations ages 16 and under must be accompanied by a non-hunting adult 21 years old or older. Bag limit is one deer either-sex per hunter (bonus deer).

* Special populations are determined by the TWRA and Tennessee Valley Authority, ie. terminally ill youth, juvenile court trustee youth program.

WILDLIFE PROCLAMATIONS

Jackson Swamp

Crow, Deer, Dove, Opossum, Rabbit,
Raccoon, Squirrel, Turkey, Waterfowl,
Woodcock

Same as statewide seasons.
Deer count toward statewide bag.

John Tully

Dove, Opossum, Raccoon, Quail, Rabbit,
Snipe, Squirrel, Woodcock

Same as statewide seasons.

Waterfowl

Same as statewide seasons, except shooting
ends at 3:00 P.M. Temporary blinds only and
decoys must be removed at the completion of
each days hunt.

Deer

Same as statewide season except antlered deer
must be spikes or must have 9 points or more.
Antlered points must be one inch or longer. Deer
count toward statewide bag.

Note: All deer taken on John Tully WMA must be checked out at Cold Creek Grocery, Woodard's
Grocery, or Lauderdale County Sheriff's Dept. and count toward the Unit A bag limit.

Kingston Refuge

Nontoxic shot required for small game hunting. Access by boat only.

Dove

Sept. 1, 3. Noon to sunset only. No dove hunters
allowed on refuge prior to 60 minutes before
legal shooting time.

Deer (Archery)

One 2-day hunt. Sept. 24-25. Hunter quota 100.
One deer, either sex (bonus deer).

Canada Goose

Sept. 1-15.

Wood duck/Teal

Same as Sept. Wood Duck/Teal seasons.

Closure

Public use, including all forms of trespass, is
prohibited from Oct. 15 through Feb. 1.

Dog Training (Daylight hours only)

Sept. 1-Oct. 14, Feb. 2-Mar. 15.

Deer (Shotgun-Muzzleloader)
(Young Sportsman)

Two 2-day hunts. Oct. 1-2, 8-9.
Hunter quota 50. One deer, either sex (bonus
deer).

WILDLIFE PROCLAMATIONS

Kyker Bottoms Refuge

Shotguns, Muzzleloaders, and Archery only.
Non-toxic shot required for small game hunting.

Closed to all use Nov. 1-Feb. 14, except in designated observation areas. All small game hunting is Young Sportsman/Adult only. Each youth must be accompanied by a licensed adult who also may hunt.

Deer

Same as statewide seasons, except closes Oct. 30. Deer count toward statewide bag.

Quail, Rabbit

Feb. 18-19, 25-26. Bag limit 3 each, per day.

Grouse, Snipe, Squirrel,
Waterfowl, Woodcock

Same as statewide seasons, except closed Nov. 1- Feb. 14. Squirrel hunting with dogs is permitted during the spring squirrel season.

Dove

Sept. 3-4, 10-11, and Oct. 8-23.
Shooting from staked positions on first come first serve. Opens at noon each day.

Raccoon

Feb. 17-18 and 24-25. Sunset to 12:00 a.m. Bag limit 3 per person.

Dog Training

Sept. 1-Oct. 31, Feb. 15-Mar. 15. Daylight hours only.

Land Between the Lakes

Squirrel

The third Saturday in August through the fourth Friday in September, October 1-16, and December 1 through the last day of February. Spring squirrel season same as statewide, dogs allowed.

Dove, Snipe, Woodcock

According to state and federal regulations, open on small game hunt dates that coincide with state seasons.

Fox, Quail, Rabbit

Dec. 1 through the last day of February.

Coyote

May be taken during daylight hours only by legally licensed hunters during any open season with weapons specified for that season.

Opossum, Raccoon

Dec. 1-Feb. 15. Sunset to sunrise. One raccoon per person per night. Some hunt areas may be closed to hunting as posted at designated hunter check stations.

WILDLIFE PROCLAMATIONS

Crow	Open during any LBL small game season that coincides with the statewide crow season.
Fox Chasing	From sunset to sunrise, third Saturday in Aug. through the third Saturday in Sept. LBL Hunter Use Permit required.
Geese	Same as the statewide goose season, except closed on deer gun hunt dates.
Ducks	Early duck season same as statewide season.
Waterfowl hunting will be allowed during the statewide season throughout the Tennessee portion of LBL except on designated, signed, refuge areas and public use areas, and on deer gun hunt dates. Permanent blinds will not be permitted.	
Dog Training (Quail, Rabbit and Raccoon chasing only)	Oct. 1 – Oct. 31. LBL Hunter Use Permit required. Training allowed only in designated areas.
Bullfrog	May 15-Aug 31. Gigs only. Bag limit 15.
Small Game (Archery Only)	Squirrel, groundhog, and fox may be taken during deer archery season only by legally licensed and equipped deer archery hunters. Statewide limits apply. Arrows must be equipped with broad-heads according to deer regulations.
Deer/Turkey (Archery)	Sept. 24 through Jan. 16, except closed during Quota hunts and one day immediately before each Quota hunt. One turkey, either sex (bonus turkey). Two white-tailed deer, no more than one antlered (bonus deer).
Deer (Gun)(Young Sportsman)	One 2-day hunt. Oct. 22-23. Hunter quota 800. One white-tailed deer, either sex (bonus deer). Each youth must be accompanied by an adult.
Deer (Gun/Muzzleloader)	One 2-day hunt. Nov. 11-12. Hunter quota 1,000. One white-tailed deer, including 700 buck-only and 300 either-sex permits (bonus deer).
Deer (Gun/Muzzleloader)	One 2-day. hunt. Nov. 26-27. Hunter quota 1,000. One white-tailed deer, including 500 buck-only and 500 either-sex permits (bonus deer).
Baiting: The placement of any bait to attract wildlife, including food or mineral substances is prohibited on LBL.	

WILDLIFE PROCLAMATIONS

Areas open to hunting:

All areas lying in Tennessee portion are open to hunting except:

1. Designated, signed, refuge areas and public use areas.
2. The back half of Rushing Bay is closed to all activity Nov. 1-Mar. 15

Field Trials:

Raccoon Field Trials, Bird Dogs, Beagles
And Retriever Field Trials

July 1-Mar. 31. Forest Service Special
Use permit required.

Trapping Season

Fourteen consecutive days beginning the
second Monday in January.
LBL Hunt Areas 15 and 16 designated problem
areas as assigned. All species to conform with
statewide regulations. Trappers must report their
harvest in accordance to LBL instructions.

Beaver Trapping

Feb. 1 – 28. All areas open except areas shaded
in gray on LBL legal Road Map or posted as no
hunting.

Legal Traps: According to statewide regulations.

Laurel Hill

Dove

Same as statewide dove season. All fields open.

Quail

Nov. 12-Jan. 22.

Rabbit, Squirrel, Woodcock

Same as statewide seasons. Squirrel hunting
with dogs allowed during the spring squirrel
season.

Beaver

May be taken on any hunt day.

Opossum, Raccoon

Nov. 18-Feb. 4. One raccoon per party, per
night.

No Fox Chasing Allowed

Dog Training (Daylight hours only)

Sept. 1-Mar. 15.

Deer*/Turkey (Archery)

Three 3-day hunts. Sept. 24-26, Sept. 30-Oct 2,
Oct. 7-9, No hunter quota. One deer, either sex
(bonus deer). One turkey, either sex.

Deer* (Gun-Archery)(Young Sportsman)

One 2-day hunt. Oct. 15-16. No hunter quota.
One deer, either sex (bonus deer).

WILDLIFE PROCLAMATIONS

Deer* (Muzzleloader-Archery)	One 4-day hunt. Oct. 27-30. Hunter quota 500. One deer either sex (bonus deer).
Deer* (Gun-Archery)	Three 3-day hunts. Nov. 11-13, 25-27, Dec. 2-4. Hunter quota 500. One deer, either sex (bonus deer).
Fall Turkey	One 3-day hunt. Dec. 9-11. Hunter quota 200. Two turkey, either sex.

* Special buck regulations apply on all hunts. Bucks must be spikes or have at least nine antler points. Antler points must be one inch or longer.

Shields Farm Unit	Same as statewide seasons. Centerfire rifles and handguns prohibited.
-------------------	---

Lick Creek Bottoms

Nontoxic shot is required for small game hunting as posted. No blinds or decoys left overnight. Dove fields open as posted. Small game hunters must wear fluorescent orange during the deer gun hunts.

Deer, Opossum, Quail, Rabbit, Raccoon, Squirrel, Turkey Waterfowl, Woodcock	Same as statewide seasons. Deer count toward statewide bag.
Dove	Sept. 1, 3, 5 and the remainder of the dove season. Hunting from noon to sunset only on Sept. 1, 3, 5.

Joachim Bible Refuge Unit (that portion Of Lick Creek WMA between Murray Bridge Road and Bibles Chapel Road.

Dove	Sept. 1, 3, 5-23. Oct 8-23. Hunting from noon to sunset only on Sept. 1, 3, 5.
------	--

Squirrel Sept. 12-Oct. 30, Feb. 15-28.

Quail, Rabbit	Feb. 18-19, 25-26. Quail and rabbit hunting is Young Sportsman/Adult only. Each youth must be accompanied by a licensed adult who may also hunt.
---------------	--

Maness Swamp Refuge

Coyote, Opossum, Quail, Rabbit, Raccoon Squirrel, Woodcock, Waterfowl	Same as statewide seasons, except all seasons closed Nov. 1-Feb. 14. Squirrel hunting with dogs allowed during spring squirrel season.
---	--

Closure	Public use, including all forms of trespass, is prohibited from Nov. 1 - Feb. 14, except as otherwise indicated.
---------	--

WILDLIFE PROCLAMATIONS

Dog Training	Sept. 1-Oct. 31, Feb. 15-28.
Deer	Same as statewide seasons, except closed to statewide archery during Young Sportsman deer hunt on Oct. 8-9 and during Nov. 1-Feb. 14. Deer count toward statewide bag.
Deer (Gun-Archery)(Young Sportsman)	One 2-day hunt. Oct. 8-9. No hunter quota. One deer, either sex (bonus deer).

Meeman-Shelby Forest State Park and Natural Area

Special Squirrel Hunt (Young Sportsman)	Aug. 20.
Dove, Opossum, Quail, Rabbit, Raccoon, Snipe, Squirrel, Woodcock	Open Mondays, Wednesdays, and Saturdays within statewide seasons. Small game hunting allowed during deer seasons. Small game hunters must wear legal hunter orange during deer gun hunts. Raccoon and opossum open Mondays, Wednesdays and Saturdays sunset to sunrise.
Dog Training	Open Monday, Wednesday, and Saturday, Sept. 1- Mar. 15.
Field Trials	Sept. 1- Apr. 30.
Deer	Open Monday, Wednesday and Saturday during statewide seasons. Successful hunters must check out at nearest county checking station. Deer count towards statewide bag limit. Closed to special season antlerless hunts.
Waterfowl	Open Monday, Wednesday and Saturday within the statewide duck season and the last seven days of the statewide duck season, except Sunday. Waterfowl hunting allowed during all deer hunts. No permanent blinds. No decoys left overnight.
Beaver	Open during any hunt date.
Arms and Ammunition	Shotgun, muzzleloader, and archery equipment only.

WILDLIFE PROCLAMATIONS

Moss Island

Dove, Opossum, Quail, Rabbit, Raccoon, Snipe, Squirrel, Waterfowl, Woodcock

Same as statewide season except closed Dec 17-18. Squirrel hunting with dogs allowed during spring squirrel season.

Deer (Archery)

Sept. 24-Oct. 28. No hunter quota. Bag limit two deer, either sex. Bucks must be spike or nine antler points or better. Deer count toward statewide bag.

Deer (Archery)

Dec. 24-Jan. 8. No hunter quota. Bag limit two deer-either sex (bonus deer). Bucks must be spike or nine antler points or better.

Deer (Gun-Muzzleloader-Archery)

One 2-day hunt. Dec. 17-18. No hunter quota. Bag limit one deer, antlered only. Bucks must be spike or nine antler points or better. Deer count toward statewide bag.

Deer (Gun-Archery)(Young Sportsman)

One 2-day hunt Oct. 29-30. No hunter quota. Deer count toward statewide bag.

Natchez Trace State Forest

Bobcat, Crow, Dove, Opossum, Quail, Rabbit Raccoon, Snipe, Squirrel, Waterfowl, Woodcock

Same as statewide seasons. Squirrel hunting with dogs allowed during spring squirrel season.

North of I-40

Deer (Archery)

Sept. 24-Oct. 7, Oct. 10-28, Nov. 12-18, Dec. 12-16. No hunter quota. Deer count toward statewide bag.

Deer (Muzzleloader-Archery)

Nov. 5-8, Dec. 5-11. No hunter quota. Deer count toward statewide bag.

Deer (Gun-Archery)(Young Sportsman)

Two 2-day hunts. Oct. 8-9, 29-30. No hunter quota. One deer, either sex (bonus deer).

Deer (Gun-Archery)

Nov. 23-26, Dec. 17-Jan.1. No hunter quota. Deer count toward statewide bag.

South of I-40

Deer (Archery)

Sept. 24-Oct. 7, Oct. 10-28, Nov. 12-18, Dec. 12-16. No hunter quota. Deer count toward statewide bag.

WILDLIFE PROCLAMATIONS

Deer (Muzzleloader-Archery)	Nov. 9-11. No hunter quota. Deer count toward statewide bag.
Deer (Gun-Archery)(Young Sportsman)	Two 2-day hunts. Oct. 8-9, 29-30. No hunter quota. One deer, either sex (bonus deer).
Deer (Gun-Archery)	Nov. 27-30, Dec. 17-Jan. 1. No hunter quota. Deer count toward statewide bag.

Nathan Bedford Forrest State Park

Deer (Muzzleloader)	One 3-day hunt. Oct. 14-16. Hunter quota 100. One deer, either sex (bonus deer).
---------------------	--

Nolichucky

Area closed to all hunting and access from Byrds Bridge Access Area ramp to the Nolichucky Dam one week before and during the late statewide duck season.

Dove	Sept. 1, 3, 5, 10. Hunting from noon to sunset only.
Deer, Grouse, Opossum, Quail, Rabbit, Raccoon, Snipe, Squirrel, Turkey, Woodcock	Same as statewide seasons, except closed one week before and during the late duck season. Squirrel hunting with dogs allowed during spring squirrel season. Deer count toward statewide bag.
Waterfowl	Same as statewide season except closed one week before and during late duck season.
Dog Training	Sept. 1-Mar. 15.

North Chickamauga Creek (Hixson, Sutton, Thrasher Bottoms, Vandergriff, Varner Units)

No motorized vehicles outside parking areas. Area closed after sunset except opossum and raccoon hunters. Hunting allowed on Tuesdays, Thursdays, and Saturdays only. All hunting ends on January 31. Shotguns loaded with #4 shot or smaller only (except waterfowl).

Snipe, Squirrel, Woodcock	Same as statewide seasons. Squirrel hunting with dogs allowed during spring squirrel season.
Rabbit	Same as statewide seasons. Bag limit is 3 per person per day.
Dove	Each Tuesday, Thursday, and Saturday during the statewide season from noon till sunset only

WILDLIFE PROCLAMATIONS

Deer	Same as statewide seasons. Archery tackle only. Archers must comply with the big game hunter orange requirements during the statewide deer gun or muzzleloader hunts. Deer count toward statewide bag.
Opossum, Raccoon	Same as statewide season. Bag limit – 1 raccoon per party per night. Hunting from sunset to sunrise only.
Waterfowl	Open each Tuesday, Thursday, Saturday, and the first and last day of the statewide season. Hunting ends at noon each day. Hunting from temporary blinds only. Decoys to be removed each day.
Trapping	Nov. 12-Jan. 31. Traps must be checked each day.
Dog Training (all breeds)	Sept. 15-Jan. 31.

North Chickamauga Creek Gorge State Natural Area Unit

No motorized vehicles outside parking areas. Area closed after sunset. No dogs are allowed and all state natural area regulations including ATVs and mountain bikes will be enforced. Hunting allowed on Tuesdays, Thursdays, and Saturdays only. All hunting ends on January 31. Shotguns loaded with #4 shot or smaller only (except waterfowl).

Snipe, Squirrel, Woodcock	Same as statewide seasons. Crow hunting closed.
Rabbit	Same as statewide seasons. Bag limit is 3 per person per day.
Dove	Each Tuesday, Thursday, and Saturday during the statewide season from noon till sunset only.
Deer	Same as statewide seasons. Archery tackle only. Archers must comply with the big game hunter orange requirements during the statewide deer gun or muzzleloader hunts. Deer count toward statewide bag.
Waterfowl	Open each Tuesday, Thursday, Saturday, and the first and last day of the statewide season. Hunting ends at noon each day. Hunting from temporary blinds only. Decoys to be removed each day.

WILDLIFE PROCLAMATIONS

Oak Ridge

Deer (Shotgun-Muzzleloader)(Gun zones only)

Three 2-day hunts. Nov. 12-13, Dec. 3-4, Dec. 17-18. Hunter quota 500. Two deer, no more than one antlered (bonus deer).

Deer (Archery)(Park City Road, Chestnut Ridge Zone)

Three 2-day hunts. Nov. 12-13, Dec 3-4, Dec. 17-18. Hunter quota 200. Two deer, no more than one antlered (bonus deer).

Deer (Archery)(Poplar Creek Road Zone)

Three 2-day hunts. Nov. 12-13, Dec. 3-4, Dec. 17-18. Hunter quota 125. Two deer, no more than one antlered (bonus deer).

Deer (Archery)(Tower Sheilding)

Three 2-day hunts. Nov. 12-13, Dec. 3-4, Dec. 17-18. Hunter quota 200. Two deer, no more than one antlered (bonus deer).

Special Regulations: Antlered deer must have a minimum of 4 points on one antler or a 15 inch minimum outside spread on all hunts. Scouting dates-6:00 a.m. to 4:00 p.m. Nov. 5 for the Nov. 12-13 permit holders only. Nov. 26 for the Dec. 3-4 permit holders only. Dec. 10 for the Dec. 17-18 permit holders only. No access by boat, except for the Haw Ridge Park Unit. Dog training prohibited. All hunters must wear fluorescent orange during all hunts, including archery hunters in the Archery Only zones. Hunters must carry, at all times, hunting license and permit, valid picture identification, and signed current hunt map.

Obion River

All Units (special regulations apply to Maness Swamp Hunting Unit)

Dove, Opossum, Quail, Rabbit, Raccoon, Snipe, Squirrel, Woodcock, Waterfowl,

Same as Statewide seasons. Squirrel hunting with dogs is permitted during the spring Deer season.

Deer (Young Sportsman)

Oct. 8-9. No hunter quota. One Deer, either sex (bonus deer). Statewide archery and small game hunting closed during this hunt.

Maness Swamp Hunting Unit (North of State Hwy 445 bordered by the South Fork and Middle Fork of the Obion Rivers as marked)

Same as statewide seasons, except closed to all activities six days prior to the first opening of the late duck season. All hunting other than waterfowl is prohibited during the late duck season.

Waterfowl

Same as statewide except hunting of waterfowl during the late duck season permitted only on Fridays, Saturdays, Sundays, and the first and last day of each segment of the late duck season. All hunting shall cease at 3:00 p.m. (CST) each day, except the last day of the season when hunting shall close at sunset.

WILDLIFE PROCLAMATIONS

Old Hickory

Beaver may be taken on any hunt.

Unit I (Hwy 109 upstream to River Mile 267)

The sub-impoundment units as posted are closed to all types of activity six days prior to the opening of the first segment of the late duck season.

Opossum, Quail, Rabbit, Raccoon,
Snipe, Squirrel, Turkey, Woodcock

Same as statewide seasons except closed after 3:00 p.m. (CST) during the late duck season. Squirrel hunting with dogs allowed during spring squirrel season.

Dove

Hunting during the first statewide segment only. Use of nontoxic shot required.

Dog Training

Sept. 1-Mar. 15, except closed during duck seasons.

Waterfowl

Hunting is permitted only from registered blind sites and staked temporary blind sites during the late duck season. Same as statewide season except waterfowl hunting shall cease at 3:00 p.m. (CST) during the late duck season except hours same as statewide on the last day of each segment of the late duck season. Raccoon and opossum hunting, trapping, and fishing are prohibited in sub-impoundments during the waterfowl season. From Hwy. 231 bridge downstream to River Mile 258.5 (Headquarters Slough), the area south of the river channel is closed to waterfowl hunting during the first segment of the dove season.

Waterfowl
(Wheelchair-bound only blind site)

Applications must be received by TWRA Region II by noon on the 4th Friday in October. Persons holding a permit for another blind are not eligible.

Deer

Same as statewide. Deer count toward statewide bag.

Unit II – (Hwy 109 downstream to Old Hickory Dam)

Dove, Deer, Opossum, Quail, Rabbit,
Raccoon, Snipe, Squirrel, Turkey,
Woodcock

Same as statewide seasons. Squirrel hunting with dogs allowed during spring squirrel season. Deer count toward statewide bag.

WILDLIFE PROCLAMATIONS

Waterfowl Same as statewide seasons. Hunting from registered blind sites only except during the early duck season. All goose hunting is from registered blinds only.

Unit III – (River Mile 267 upstream to River Mile 281)

Deer, Dove, Opossum, Quail, Rabbit
Raccoon, Snipe, Squirrel, Turkey,
Woodcock Same as statewide seasons. Squirrel hunting with dogs allowed during the spring squirrel season. Deer count toward statewide bag.

Waterfowl Same as statewide seasons. Hunting from temporary blinds only. Decoys must be picked up each day.

Old Hickory Lock 5 Refuge

Deer, Turkey (Archery) Sept. 24- Oct. 28. Bag limit same as statewide. Deer count toward statewide bag.

Closure Public use, including all forms of trespass, is prohibited from Nov. 1 through Feb. 15, except as otherwise indicated. Public entry and fishing permitted while on the main river channel passing through the refuge.

Spring squirrel Same as statewide, dogs allowed.

Dog Training Sept. 1- Oct. 14, Feb.1-Mar. 15.

Paint Rock Refuge

Closed to all forms of public use, including all forms of trespass, from Oct. 15 through Feb. 1, except as otherwise indicated. Public entry and fishing permitted while on the main river channel through the refuge.

Canada goose Sept. 1-15.

Wood Duck/Teal Same as Sept. Wood duck/Teal season.

Dog Training (Daylight hours only) Sept. 1-Oct. 14, Feb. 2-Mar. 15.

Pea Ridge

Crow, Deer, Dove, Opossum, Quail, Rabbit,
Raccoon, Squirrel, Turkey, Waterfowl,
Woodcock Same as statewide seasons. Squirrel hunting with dogs allowed during spring squirrel season. Deer count toward statewide bag.

WILDLIFE PROCLAMATIONS

Percy Priest

Except for raccoon, opossum, and bullfrog hunting, Unit I closed to all activity from sunset to one-half hour before sunrise.

Beaver May be taken only during small game hunts.

Unit I

All activities except dove hunts on designated fields and scheduled field trials prohibited on Fridays, Saturdays, and Sundays from Sept. 17-Apr. 23.

Dove Sept. 1, and each Saturday and Sunday thereafter during the statewide season. Shooting from staked positions only. On September 1, staked positions will be assigned by a drawing held on site at 10:00 A.M. and hunters must check out at the conclusion of their hunt. Successful applicants must be at their staked position at the start of shooting hours.

Squirrel Same as statewide season. Squirrel hunting with dogs allowed during spring squirrel season.

Deer, Turkey (Archery Only) Same as statewide seasons. Deer count toward statewide bag.

Quail, Rabbit (Young Sportsman) Oct. 1-Dec. 26. Shotguns only. Each young sportsman must be accompanied by an adult who may not hunt or carry weapons. Each adult must possess a valid hunting license and an area permit.

Dog Training Sept. 1-April 30. Small game permit required. Training from horseback prohibited prior to Oct. 1. Participants of sanctioned field trials may train 72 hours prior to and after scheduled dates without a small game permit. Blank ammunition only.

Retriever Dog Training and Trials. Year-round in designated areas only. Trials must be scheduled with Area Manager and special field trial permits must be obtained from the Region II Office at least 30 days in advance of trial dates. Participants of sanctioned field trials may train 72 hours prior to and after scheduled dates without a small game hunt permit.

Bird and Rabbit Dog Trials Sept. 1-April 30. Trials must be scheduled with Area Manager and special field trial permits must be obtained from the Region II Office at least 30 days in advance of trial dates. Field trial

WILDLIFE PROCLAMATIONS

	gallery must be kept out of standing or planted crops by marshals provided by sponsoring club.
Horseback Riding	Horses permitted on all areas except freshly planted and standing crops, and special areas as posted.
Unit II Muzzleloader, archery, and shotguns with rifled slugs only for deer.	
Deer, Dove, Opossum, Quail, Rabbit, Raccoon, Snipe, Squirrel, Turkey, Woodcock	Same as statewide seasons. Squirrel hunting with dogs allowed during the spring squirrel season.
Waterfowl	Same as statewide seasons. Temporary blinds only. Blinds and decoys must be removed each day. No waterfowl hunting in the Poole Knobs Rest Area.
Dog Training	Sept. 1-April 30. No hunting or training from horseback.
Archery Practice	Open year-round designated range site (Poole Knobs) only. Target arrows only.

Prentice Cooper State Forest

ORVs, horseback riding, bicycles, and all other vehicles are restricted to roads marked "open to vehicular traffic". Organized competition events for motorized/non-motorized vehicles prohibited. Maximum noise limit of 86 dBA for all motorized vehicles, as measured 50 feet from the exhaust.

Reckless operation of motorized and non-motorized vehicles prohibited. Reckless operation is defined as operating a vehicle in a reckless or negligent manner as to endanger the life, limb, or property of any person or damage TWRA property or developments. Speed limit is 25 mph.

Dove, Grouse, Rabbit, Snipe Squirrel, Woodcock	Same as statewide seasons. Squirrel hunting with dogs allowed during spring squirrel season.
Opossum, Raccoon	Third Friday in Oct.-Jan. 30, except hunting will be limited to Friday and Saturday nights only. All hunting ends Jan. 30. Bag limit is 1 per person per night.
Deer (Archery)	One 3-day hunt. Sept. 17-19. Hunter quota 500. One deer, either sex (bonus deer).

WILDLIFE PROCLAMATIONS

Deer (Archery)	Two 3-day hunts. Sept. 20-22, 23-25. No hunter quota. One deer, either sex (bonus deer). No area checking station opened.
Deer (Muzzleloader)	One 3-day hunt. Oct. 20-22. Hunter quota 250. Two deer, no more than one antlered (bonus deer).
Deer (Gun-Archery)	One 2-day hunt. Nov. 11-12. No hunter quota. One deer, buck only (bonus deer).
Deer (Gun-Archery)	One 6-day hunt. Nov. 26-Dec. 1. No hunter quota. Two deer, buck only (bonus deer).
Deer (Gun-Archery)(Young Sportsman)	One 2-day hunt. Oct. 29-30. No hunter quota. One deer, either sex (bonus deer).

Presidents Island

Deer (Archery Only) (Excluding Ensley Unit)	<p>Two 3-day hunts. Oct. 14-16, 21-23. Hunter quota 100 each hunt. Bag limit two deer (bonus deer), which may be antlerless or spike bucks. Scouting dates - Oct. 13 for the Oct. 14-16 permit holders only; Oct. 20 for the Oct. 21-23 permit holders only.</p> <p>One 3-day hunt. Dec. 2-4. Hunter quota 50. One deer, either sex (bonus deer). Bucks must have at least nine antler points. Antler points must be one inch or longer. Scouting date – Dec. 1 for the Dec. 2-4 permit holders only. Hunters must check in at hunter check station before hunting and check out at completion of each day's hunt. Permit will be held while hunters hunt. Access permitted from Farm Road only. No access permitted from Mississippi River, McKellar Lake, or from the Causeway. Access allowed only to TWRA authorized personnel and permit holders.</p>
Deer (Archery only)(Ensley Unit)	One 3-day hunt. Dec 2-4. Hunter quota 30. One deer, buck only (bonus deer). Bucks must have at least nine antler points. Antler points must be one inch or longer. Scouting date – Dec. 1 for the Dec. 2-4 permit holders only. Access permitted from Shelby Drive only. Access allowed only to TWRA authorized personnel and permit holders.

WILDLIFE PROCLAMATIONS

Rankin

No blinds or decoys left overnight. Shotguns only for small game hunting.

Deer, Dove, Grouse, Opossum, Quail,
Rabbit, Raccoon, Snipe, Squirrel
Turkey, Waterfowl, Woodcock

Same as statewide seasons. Waterfowl hunting allowed during deer season. Small game hunters (except waterfowl) must wear fluorescent hunter orange during big game hunts. Deer count toward statewide bag.

Reelfoot

Dove, Quail, Rabbit, Snipe, Squirrel,
Woodcock

Same as statewide seasons. Squirrel hunting with dogs allowed during spring squirrel season.

Opossum, Raccoon

Sept. 12-Dec. 31. No bag limit.

Deer (Archery)

Three hunts. Sept. 24-Oct. 28, Oct. 31-Nov. 15, Nov. 23-Jan. 1. No hunter quota. Three deer, either sex per segment (bonus deer). Small game hunting open during archery hunts.

Deer (Gun-Archery)(Young Sportsman)

One 2-day hunt. Oct. 29-30. No hunter quota. Deer count toward statewide bag.

Deer (Gun-Archery)

One 4-day hunt. Nov. 19-22. No hunter quota. One deer, buck only (bonus deer).

Waterfowl

Same as waterfowl zone seasons. Waterfowl hunting closed at 3:00 p.m. (CST) except for last day of each segment of the late duck and the remaining Reelfoot goose seasons when hunting shall cease at sunset.

Waterfowl (Wheelchair-bound only blind sites)

Application must be received by the TWRA Region I Office by noon on the 4th Friday in October. Persons holding a permit for another blind are not eligible to compete in the wheelchair-bound blind drawing. If blind is not occupied by shooting time, another wheelchair-bound hunter and 1 to 3 assistants (at least one assistant must be age 16 or older) may occupy the blind for that day. Hunting restricted to wheelchair hunters and assistants only within the marked wheelchair hunting zone at designated blinds.

WILDLIFE PROCLAMATIONS

Royal Blue

All users should be aware that hazards associated with mining (deep and strip) exist on this area. Public use is allowed during all hunts. During daylight hours, all users outside of an enclosed vehicle or out of camp must wear fluorescent orange during the deer gun and muzzleloader seasons.

No person shall remove minerals, including coal, trees, plants (including vines), or building stone from the area without specific authorization.

Camping is allowed on the entire area.

ORV, horseback riding, bicycles, and all other vehicles are restricted to roads marked "open to vehicular traffic".

Ginseng season – Same as statewide.

Night-time use by the general public and raccoon hunters is permitted area-wide.

Organized competition events for motorized/non-motorized vehicles prohibited.

Maximum noise limit of 86 dBA for all motorized vehicles, as measured 50 feet from the exhaust.

Reckless operation of motorized and non-motorized vehicles prohibited-reckless operation is defined as operating a vehicle in a reckless or negligent manner as to endanger the life, limb, or property of any person or damage TWRA property or developments. Speed limit is 25 mph.

Hunting Seasons:

Grouse, Opossum, Rabbit, Raccoon,
Snipe, Squirrel, Waterfowl, Woodcock

Same as statewide except hunting season closed March 1 to Aug. 27, except for turkey hunts and spring squirrel season.

Deer

Same as statewide Unit B seasons. Deer count toward statewide bag.

Dog Training

Sept. 1- Mar. 1.

South Fork Refuge

Dove, Opossum, Quail, Rabbit, Raccoon
Snipe, Squirrel, Woodcock, Deer

Same as statewide seasons, except closed to all activities six days prior to the first opening of the late duck season. All hunting other than waterfowl is prohibited during the late duck season. Deer count toward statewide bag.

Waterfowl

Same as statewide except hunting of waterfowl during the late duck season permitted on Saturdays and Sundays, and the first and last day of each segment of the late duck season. All hunting shall cease at 3:00 p.m. (CST) each day,

WILDLIFE PROCLAMATIONS

except the last day of the season when hunting shall close at sunset. Walk-in only. Temporary blinds only and decoys must be removed at the completion of each day's hunt.

Sundquist

All users should be aware that hazards associated with mining (deep and strip) exist on this area. Public use is allowed during all hunts. During daylight hours, all users outside of an enclosed vehicle or out of camp must wear fluorescent orange during the deer gun and muzzleloader seasons.

Organized events for motorized/non-motorized events prohibited.

Ginseng season- same as statewide

Hunting Seasons:

Grouse, Opossum, Rabbit, Raccoon, Quail, Snipe, Squirrel, Waterfowl, Woodcock,

Same as statewide except hunting season closed March 1 to Aug. 26, except for turkey hunts and spring squirrel season

Deer

Same as statewide Unit B season. Deer count toward statewide bag.

Dog Training

Sept. 1- Mar. 1.

Tellico Lake (Field Trial Permit Required.)

Deer, Dove, Grouse, Opossum, Quail, Rabbit, Raccoon, Snipe, Squirrel, Waterfowl, Woodcock

All areas except Chota, Niles Ferry, and McGhee-Carson Units are the same as statewide seasons. No blinds or decoys left overnight. Squirrel hunting with dogs is permitted during the spring squirrel season.

McGhee-Carson Unit - (that peninsula of Ft. Loudoun State Historic Park at LTRM 21.0)
All small game hunting is Young Sportsman/Adult only. Each youth must be accompanied by a licensed adult who may also hunt.

Dove

Sept. 5. Shooting from staked positions on first come first serve. Opens at noon

Rabbit, Squirrel
(Shotguns and Archery only)

Each Saturday and Sunday during the statewide season, except closed during scheduled field trials, and big game hunts.

Field Trials- Retriever

Year-round in designated areas only. Trials must be scheduled with Area Manager and special field trial permit must be obtained from the Region IV Office at least 30 days prior to trial dates.

WILDLIFE PROCLAMATIONS

Dog Training	Year-round, except closed during field trials and big game hunts.
Horses	Horses permitted, except in freshly planted and standing crops and special areas as posted.
Deer (Shotgun only)(Young Sportsman)	One 1-day hunt. Nov. 5. Hunter quota 35. One deer, either sex (bonus deer).
Deer (Shotgun-Archery) (Wheelchair-bound Only)	One 2-day hunt. Nov. 19-20. No hunter quota. One deer, either sex (bonus deer).
Chota Refuge Unit –(that portion from LTRM 26.0 upstream to the Hiwassee – Alcoa Powerline at LTRM 29.7)	
Deer, Dove, Grouse, Opossum, Quail, Rabbit, Raccoon, Snipe, Squirrel, Waterfowl, Woodcock	Same as statewide except all seasons closed Nov. 1- Feb. 14. Dove hunting allowed in fields as posted; non-toxic shot required. Squirrel hunting with dogs is permitted during the spring squirrel season. Deer count toward statewide bag.
Dog Training	Sept. 1- Mar. 15, except closed Nov. 1-Feb. 14.
Field Trials	Feb. 15-Oct. 31. Trials must be scheduled with Area Manager and special field trial permit must be obtained from the Region IV Office at least 30 days prior to trial dates.
Niles Ferry Unit (that portion of the Niles Ferry Industrial Park at LTRM 18.0 as posted).	
Dove	Sept. 1, 3, 5 (opens at noon) and Sept 10-11.
Deer (Shotgun-Muzzleloader) (Young Sportsman)	Four 1-day hunts. Nov. 5, 6, 12, 13. Hunter quota 35. One deer, either sex (bonus deer). Access by Industrial Rd. only. Sign up for drawing will be held at the Tellico Lake WMA Office between 9:00 a.m. and 11:00 a.m. on Oct. 2. Youth must be present at sign up and drawing.
Small game (Falconry Only)	Jan. 1-Feb. 28
Wears Bend Unit (That portion of Tellico Reservoir Development Agency Industrial Park at LTRM 18.)	
Deer, Dove, Grouse, Opossum, Quail, Rabbit, Raccoon, Snipe, Squirrel, Waterfowl, Woodcock	Same as statewide seasons. Squirrel hunting with dogs is permitted during the spring squirrel season. Deer count toward statewide bag.

WILDLIFE PROCLAMATIONS

Horses
Horses permitted, except in freshly planted and standing crops and special areas as posted.

Volunteer Army Ammunition Plant

Deer (Archery)
Two 2-day hunts. Oct. 22-23, Nov 12-13. Hunter quota 150. Two deer, no more than one antlered (bonus deer). Scouting day-7:00 a.m. to 4:00 p.m. on Oct. 15.

Whites Mill Refuge

Closed to all forms of public use, including all forms of trespass, from Nov. 1-Feb. 15, except as otherwise indicated. Horseback riding prohibited.

Dog Training
Feb. 15-28.

Bullfrog
July 1-Aug. 31, gigs only.

Williamsport

Open 1 hour before sunrise until 1 hour after sunset on hunt days.

Quail, Rabbit, Squirrel, Woodcock
Same as statewide seasons. Squirrel hunting with dogs allowed during the spring squirrel season.

Dove
Same as statewide season, except open only on Sept. 1 and every Saturday during the first segment. Designated fields only. Shooting from staked positions only on Sept 1. On Sept 1, staked positions will be assigned by a drawing held on site at 10 AM. Hunters must be present at drawing and must check out at the conclusion of the hunt. Successful applicants must be on stake at legal shooting hours.

Deer (Archery)
Two 3-day hunts. Sept. 24-26, Sept. 30-Oct. 2. No hunter quota. One deer, either sex (bonus deer)

Deer (Gun-Archery)(Young Sportsman)
One 2-day hunt. Oct. 8-9. No hunter quota. One deer, either sex (bonus deer).

Deer (Muzzleloader-Archery)
One 3-day hunt. Oct 28-30. Hunter quota 100. One deer, either sex (bonus deer).

WILDLIFE PROCLAMATIONS

Deer (Gun-Archery)	Three 3-day hunts. Nov 11-13, Dec. 2-4, Dec 16-18. Hunter quota 100. One deer, either sex (bonus deer).
Dog Training (Daylight hours only)	Sept. 1-Mar. 15.

Wolf River

Adjacent Ghost River State Natural Area open same as Wolf River WMA. Hunting or access to hunt from the boardwalk structure is prohibited. All small game and archery hunting is closed during youth deer hunts. Closed to fall turkey hunts. No centerfire rifles.

Crow, Dove, Furbearers, Squirrel, Woodcock, Snipe	Same as statewide season.
Waterfowl	Closes at 3:00 p.m. each day of the late season. Blinds and decoys must be removed each day.
Rabbit	Nov. 12 – Jan. 31
Quail	Dec. 1 – Jan. 31
Deer	Same as statewide seasons with the exception that archery tackle and crossbows only after the first muzzleloader season through the end of statewide deer seasons. Fluorescent orange must be worn by archers and crossbow hunters from Nov. 19 through the remainder of the season. Tree stands must be marked with hunter's TWRA ID number. Deer count toward statewide bag.
Deer (Gun-Archery)(Young Sportsman)	One 2-day hunt. Oct. 8-9. No hunter quota. One deer, either sex (bonus deer).
Dog Training	Sept. 1- Mar. 15, except closed during deer gun hunts.
Field Trials	By permit from Area Manager.

Yanahli

Opossum, Quail, Rabbit, Raccoon, Snipe, Squirrel, Turkey, Woodcock, Waterfowl	Same as statewide seasons. Squirrel hunting with dogs allowed during spring squirrel season.
Dove	Sept 1 and each day of the statewide season thereafter. Hunting on designated fields only and shooting from staked positions only on Sept 1.

WILDLIFE PROCLAMATIONS

On Sept 1, staked positions will be assigned by a drawing held on site at 10 AM. Hunters must be present at drawing and must check out at the conclusion of the hunt. Successful applicants must be on stake at legal shooting hours.

Deer

Same as statewide seasons, except all deer hunting closes after Dec. 16. Deer count toward statewide bag.

Dog Training

Aug. 1- Mar. 15.

Yuchi Refuge at Smith Bend

Nontoxic shot only in wetland zones. No boat access. No ATV, ORV, or horse-back riding permitted. Small game hunting closes at sunset the day before and during scheduled big game hunts.

Dove

Sept. 3. Young Sportsman only. Bag limit 10 per day. Noon till sunset only.

Sept. 5-21. Noon till sunset only. Bag limit 10 per day.

Squirrel

Aug. 27-Dec. 31. Upland Zone only after Nov. 14. Bag limit 5 per day.

Opossum, Raccoon

Same as statewide except hunting permitted on Wednesdays and Thursdays only, sunset to sunrise. Closed after Nov. 10. All dogs need to be removed from the area prior to sunrise on Friday. Bag limit on raccoons, one per party per night. No limit on opossums.

Rabbit

Nov. 5-Jan. 31. Upland Zone only after Nov. 14. Bag limit 3 per day.

Dog Training

Sept. 1-Mar. 15 in Upland Zone. Sept. 1-Nov. 14 and Mar. 1-15 in Wetland Zone. Daylight hours only. No fox or coyote chasing.

Retriever Field Trials

Pre-approved by area manager at least 30 days in advance of trial dates.

Wood Duck/Teal

Same as Sept. Wood duck/Teal season except hunting ends at noon. No waterfowl hunters on the area after 2:00 P.M. until 4:00 A.M. the following day.

WILDLIFE PROCLAMATIONS

Deer (Gun-archery)(Young Sportsman)	Two 2-day hunts. Sept. 24-25, Oct. 29-30. Hunter quota 75 each hunt. Two deer, only one antlered (bonus deer).
Deer, Turkey (Archery)	Two 2-day hunts. Sept. 17-18, Oct. 15-16. Hunter quota 100 each hunt. Two deer, no more than one antlered (bonus deer). One turkey, either sex.
Deer (Muzzleloader)	One 2-day hunt. Oct. 22-23. Hunter quota 50. One deer, either sex (bonus deer).
Deer (Gun/Muzzleloader)	One 2-day hunt. Nov.5-6. Hunter quota 50. Two deer, no more than one antlered (bonus deer).
Deer (Wheelchair Bound Only)	One 2-day hunt. Nov. 12-13. No hunter quota. One deer, either sex (bonus deer).
Arms and Ammunition	Nontoxic shot only in Wetland Zone.
Closure	Wetland Zone closed to all forms of public use, including all forms of trespass from Nov. 15 through the last day of Feb.

Special Regulations: Antlered deer must have a minimum of 4 points on one antler or a 15 inch minimum outside antler spread on all hunts.

The following wildlife management areas are open to trapping as set out in the statewide Season, unless otherwise indicated:

(Small Game WMA permit is required to trap on all areas that require a small game hunt permit.)

Note: Red Fox may be taken during Statewide Trapping Season

AEDC	Cordell Hull	Normandy
Alpine Mountain	Cove Creek	Obion River
Arnold Hollow	Doe Mountain	Old Hickory
Bark Camp Barrens	Ernest Rice, Sr.	Owl Hollow Mill
Barkley Unit I (1)	Foothills	Pea Ridge
Barkley Unit II	Harmon Creek	Percy Priest (Unit II)
Beaver dam Creek	Haynes Bottom	Pickett State Forest
Big Sandy (1)	Hick Hill	Prentice Cooper State Forest (7)
Bridgestone/Firestone (7)	Hickory Flats	Rankin
Browntown	Laurel Hill (5)	Reelfoot (15)
Buffalo Springs	LBL	Royal Blue (11)
Camden Unit I (1)	Lick Creek	Shelton Ferry
Camden Unit II	Lick Creek Bottoms	Standing Stone State Forest (4)
Catoosa (6)	Long Pond	Sundquist
Cedar Hill Swamp	Moss Island	Tie Camp
Cheatham (5)	Maple Springs	Tigrett

WILDLIFE PROCLAMATIONS

Cheatham Lake	Mingo Swamp	John Tully
Cherokee-North Unit	Mt. Roosevelt	Tumbleweed
Cherokee-South Unit (12)	MTSU	Watts Bar (9)
Chickamauga (8)	Natchez Trace State Forest (2)	West Sandy (1)
Chickasaw State Forest	Meeman-Shelby Forest State Park and Natural Area (10)	White Oak
Chuck Swan State Forest (13)	New Hope	Wolf River
C.M. Gooch (3) Cold Creek	New Hope	Yanahli

1. No trapping during duck season.
2. All areas open except Pin Oak Lake.
3. No trapping during the duck season in Units "A" and "E".
4. No Fox Trapping.
5. Jan. 4- Feb. 4.
6. Jan. 1-31.
7. Dec. 16-28.
8. No trapping during the duck season on Candies Creek, Johnson Bottoms, Rogers Creek, and Yellow Creek Units.
9. No trapping during the duck season on the Long Island Unit.
10. Beaver trapping by special permit only. Trapping of all other species prohibited.
11. Beaver trapping prohibited.
12. Jan. 1- Feb. 15.
13. No raccoons. Jan. 8- Jan. 31. Quota 1 party per compartment. Trappers must apply at WMA office. No snares or conibear traps. Trappers must report catch annually.
14. Trapping season is fourteen consecutive days beginning the second Monday in January. LBL Hunt Areas 12 and 14 and designated problem areas as assigned. All species to conform with statewide regulations. Trappers must report their harvest in accordance to LBL instructions. Beaver trapping Feb. 1-28. All areas open except areas shaded in gray on LBL legal Road Map or posted as no hunting. Legal Traps: According to statewide regulation.
15. A Reelfoot Preservation Permit is required instead of a Small Game WMA permit.

SECTION III. REPEAL OF PRIOR PROCLAMATIONS

This proclamation repeals Proclamation No. 04-11 dated May 20, 2004.

Proclamation No. 05-14 received and recorded this 31st day of May, 2005. (05-40)

WILDLIFE PROCLAMATIONS

TENNESSEE WILDLIFE RESOURCES COMMISSION - 1660

PROCLAMATION 05-15 REGULATING SPRING WILD TURKEY HUNTING SEASONS AND BAG LIMITS

Pursuant to the authority granted by Tennessee Codes Annotated Sections 70-4-107 and 70-5-108, the Tennessee Wildlife Resources Commission hereby proclaims the following spring hunting seasons and bag limits for wild turkey hunting effective August 1, 2005.

SECTION I. GENERAL REGULATIONS

A. Prohibited Acts

The use of any type of food to feed or attract wild turkeys on WMAs. Shooting or stalking turkeys from a boat in Shelby, Dyer, Tipton, Lauderdale, Haywood or Obion counties prohibited. Calling or attempting to call wild turkeys using any call to mimic the sounds made by a wild turkey is prohibited from March 1st to the opening day of the spring turkey hunts on all WMAs.

A licensed turkey hunter, who has filled his bag limit or does not possess a valid permit for a quota hunt, may accompany another turkey hunter (except on WMAs where prohibited) and assist him in calling, but may not have a gun or bow in his possession.

B. Bag and Possession Limits ¹

Statewide-One bearded turkey per day, not to exceed four per season,
(Includes turkeys taken on WMAs listed in Section III. D. below)

Wildlife Management Areas and Refuges (Except those WMAs listed in Section III.D)
One bearded turkey per hunt not to exceed two per season.

Young Sportsmen hunt-One bearded turkey

C. Shooting Hours - Thirty (30) minutes before sunrise to sunset

D. Checking Stations - All hunters must check in at the area checking station prior to hunting on AEDC, Catoosa, Cheatham, Chuck Swan State Forest, Laurel Hill, LBL, Meeman Shelby Forest State Park and Natural Area, Natchez Trace State Forest, Prentice Cooper State Forest, Reelfoot, and Williamsport WMAs. Hunters are also required to check out at the conclusion of their hunt. All turkeys harvested on the statewide hunt or on WMAs must be taken by the most reasonably direct route to the nearest county or WMA check station on the day harvested. The permanent kill tag required for the legal possession will be issued at the checking station.

¹ The total bag and possession limit shall not exceed four bearded turkeys per season on the statewide season and WMAs combined. Turkeys taken on Ft. Campbell, Chickasaw NWR, Lower Hatchie NWR, Reelfoot NWR, WMA quota turkey hunts and young sportsmen hunts are bonus birds and do not count toward the total season bag and possession limit.

WILDLIFE PROCLAMATIONS

SECTION II. STATEWIDE TURKEY HUNTING SEASONS

(Exclusive of WMAs and Refuges unless listed in Section III.D below)

- A. Statewide Turkey Season Dates – April 1 through May 14, 2006
- B. Statewide Young Sportsmen Hunt (6-16 years of age) – March 25-26, 2006. Each youth must be accompanied by a non-hunting adult 21 years of age or older, who must remain in a position to take immediate control of the hunting device, who is not required to have a license.

SECTION III. WILDLIFE MANAGEMENT AREAS - SEASONS AND MISCELLANEOUS REGULATIONS

On all Young Sportsman Hunts, youth, ages 6-16, may participate but must be accompanied by an adult, 21 years of age or older, who must remain in a position to take immediate control of the hunting device. Adults cannot hunt except as indicated otherwise.

Youth, ages 6-16, may participate on other WMA turkey hunts but must be accompanied by an adult, 21 years of age or older, who must remain in a position to take immediate control of the hunting device except as otherwise noted.

- A. Regular Managed Hunts (No Hunter Quota)-Bag Limit - One bearded turkey per hunt not to exceed two turkeys per spring season (See Section I.B.).

AEDC	Four 3-day hunts: April 1-3, 7-9, 21-23, and 28-30
Catoosa	Six 3-day hunts: April 7-9, 14-16, 18-20, 25-27, 28-30, May 2-4 One 2-day Young Sportsmen hunt: April 22-23
Cheatham	Five hunts: April 1-3, 7-9, 14-16, 19-23, 27-30 One 2-day Young Sportsmen hunt: March 25-26
Ernest Rice	One 2-day Young Sportsmen hunt: March 25-26
Fall Creek Falls State Park	Two hunts: April 8-12, 22-26 (Archery Only)
Kyker Bottoms	All hunting is Young Sportsman (6-16 years of age): Same as Statewide Season. Each youth must be accompanied by an adult, 21 years of age or older, who may also hunt except on the March 25-26 Young Sportsmen hunt.
Laurel Hill	Six 3-day hunts: April 1-3, 7-9, 14-16, 21-23, 28-30, May 5-7

² Wheel Chair Only Hunting Zone – That portion of Cordell Hull WMA known as the Old Roaring Fork Campground (as posted).

WILDLIFE PROCLAMATIONS

LBL	Two 7-day hunts: April 17-23, April 24-30. Hunters harvesting a turkey on a LBL quota hunt (Sect. III.B) may not hunt on the April 17-23 hunt.
Meeman-Shelby Forest State Park and Natural Area	One 1-day Young Sportsmen hunt: March 25
Moss Island	One 2-day Young Sportsmen hunt: March 25-26
Natchez Trace State Forest	One 7-day hunt: April 24-30
North Chickamauga (Natural Area Unit Only)	Open with Statewide season except no hunting on Saturday Creek or Sunday. Hunting ends at noon each day.
North Chickamauga Creek	Open with Statewide season. Hunting allowed on Tuesdays, Thursdays and Saturdays only. Hunting ends at noon each day.
Prentice Cooper State Forest	Six 3-day hunts: April 4-6, 7-9, 11-13, 20-22, 25-27, April 28-30
Williamsport	Two 3-day hunts: April 1-3, 14-16
Wolf River	One 2-day Young Sportsmen hunt: March 25-26
B.	Quota Managed Hunts (Quota turkey permit required)-Bag Limit-One bearded turkey per hunt not to exceed two per spring season (See Sect. I.B.)
Chuck Swan State Forest	Seven 3-day hunts: March 30- April 1, 6-8, 13-15, 20-22, 27-29, May 4-6, 11-13 (125 hunter quota per hunt). Hunting ends at noon each day, hunters must be at check station by 1 p.m.
Ernest Rice	One 2-day hunt: April 15-16 (30 hunter quota).
Holly Fork	One 2-day hunt: March 25-26 (4 hunter quota). Youth special populations only, ages 6-16. Youth special populations are determined by the TWRA and Tennessee Valley Authority (ie. life threatening medical condition, juvenile court trustee youth program). Youth must be accompanied by a non-hunting adult 21 years of age or older, who must remain in a position to take immediate control of the hunting device.
LBL	Two 2-day hunts: April 11-12, 15-16 (350 quota per hunt) One 2-day Young sportsmen hunt: April 8-9 (300 hunter quota).

WILDLIFE PROCLAMATIONS

Meeman-Shelby Forest State Park and Natural Area	Three 3-day hunts: April 3, 5, 8, April 10, 12, 15, and April 17, 19, 22 (50 hunter quota per hunt). Successful hunters must check out at nearest county check stations.
Moss Island	One 2-day hunt: April 15-16 (30 hunter quota).
Natchez Trace State Forest	Three 3-day hunts: April 7-9, 14-16, 21-23. 96 hunter quota per hunt (48 south of I-40 only and 48 north of I-40 only). Hunters must sign in and out each day they hunt.
Oak Ridge	Two 2-day hunts: April 1-2, 8-9 (175 hunter quota per hunt). Hunting ends at noon daily, successful hunters must be at check station by 1 p.m. Scouting date for permit holders only March 25(6am to noon). Hunts subject to cancellation for national security. Hunting area may be reduced.
Reelfoot WMA and Black Bayou Refuge	One 3-day hunt: April 14-16 (20 Hunter quota).
Wolf River	Two 3-day hunts: April 14-16 (25 hunter quota) and April 21-23(30 hunter quota). Hunting ends at noon each day and successful hunters must check birds at Wolf River Check Station by 1p.m.
Yuchi Refuge (at Smith Bend)	Five three-day hunts: March 31-April 2, April 7-9, 21-23, 25-27, May 2-4(10 hunter quota per hunt). Hunting ends at Noon EST. Walk-in only. No Access by Boat.
C. Special Managed Hunts (No Hunter Quota)	
Cordell Hull (Wheel Chair Bound Only Hunting Zone) ² South Cherokee and Foothills	April 1-May 14. Wheel chair bound hunters only. Bag limit – two turkeys either-sex per season April 1- May 14. Bag limit - one bearded turkey per day not to exceed 2 per season. Turkey counts in WMA bag limit. March 25-26. Young Sportsmen hunt to coincide with the statewide young sportsmen hunt. Bag limit is one bearded bird and counts as a statewide bird.
Fourth Fractional	April 1- May 14 (Archery only). Bag limit – one bearded turkey per day not to exceed 2 per Season. Turkey counts toward statewide bag limit.

WILDLIFE PROCLAMATIONS

D. Wildlife Management Areas and Refuges Open With Statewide Seasons and Bag Limits:

Alpine Mountain, Arnold Hollow, Bark Camp Barrens, Barkley (Units I and II), Bean Switch Refuge, Beaver Dam Creek, Big Sandy (including Gin Creek), Bogota, Bridgestone/Firestone, Browntown, Buffalo Springs, Camden (Units I and II), Cedar Hill Swamp, Chickamauga, Chickasaw State Forest, Cheatham Lake, Cheatham Lake Pardue Pond Refuge and Dyson Ditch Refuge, Cold Creek Refuge, Cordell Hull, Cordell Hull Refuge, Cove Creek, Cove Mountain, Cypress Pond Refuge, Doe Mountain, Eagle Creek, Edgar Evins State Park, Flintville Hatchery, Gallatin Steam Plant (Archery only), Gooch, Harmon's Creek, Haynes Bottom, Henderson Island, Hick Hill, Hickory Flats, Hop-in Refuge, Horns Bluff Refuge, Jarrell Switch, Jackson Swamp, John Tully, Keyes-Harrison, Lick Creek, Lick Creek Bottoms, Long Pond, Maness Swamp Refuge, Maple Springs, Mingo Swamp, MTSU, Mt. Roosevelt, New Hope, Nolichucky, Normandy, North Cherokee, Obion River, Old Hickory (including Lock 5 Refuge), Owl Hollow Mill, Pea Ridge, Percy Priest Unit I (archery only) and Unit II, Pickett State Forest, Rankin, Royal Blue, Shelton Ferry, Standing Stone State Forest, Sundquist, West Sandy, Tellico Lake (except McGhee-Carson and Niles Ferry Units), Tie Camp, Tigrett, Tumbleweed, Watts Bar, White Lake Refuge, White Oak, Yanahli are open to coincide with the statewide seasons and bag limits.

SECTION IV. NATIONAL WILDLIFE REFUGE HUNTS-FEDERAL PERMIT REQUIRED. BAG LIMIT-ONE BEARDED TURKEY PER SEASON (Counts As A Bonus Bird Unless Otherwise Noted).

Chickasaw NWR	Three 3-day hunts. April 7-9, 14-16, 21-23. Hunter quota 50 per hunt. Non-toxic shot only.
Lower Hatchie NWR	Three 3-day hunts. April 7-9, 14-16, 21-23. Hunter quota 25 per hunt. Non-toxic shot only.
Hatchie NWR	April 1–May 14. Non-quota (counts in statewide bag). March 25-26 – Young Sportsmen hunt to coincide with the statewide youth hunt and bag limit. Non-toxic shot only.
Tennessee NWR and Cross Creeks NWR	April 1–May 14. Non-quota (counts in statewide bag). March 25-26 – Young Sportsmen hunt to coincide with the statewide youth hunt and bag limit.
Reelfoot NWR	One three-day hunt. April 7-9. Hunter quota: Grassy Island-25, Long Point-25. Non-toxic shot only

SECTION IV. REPEAL OF PRIOR PROCLAMATIONS

This proclamation repeals Proclamation 04-21 dated Dec 2, 2004.

Proclamation No. 05-15 received and recorded 2005 this 31st day of May, 2005. (05-41)



CERTIFICATE OF APPROVAL

As provided by T.C.A., Title 4, Chapter 5, I hereby certify that to the best of my knowledge, this issue of the Tennessee Administrative Register contains all documents required to be published that were filed with the Department of State in the period beginning May 2, 2005 and ending May 31, 2005.

A handwritten signature in black ink that reads "Riley C. Darnell". The signature is written in a cursive style with a large initial "R".

RILEY C. DARNELL
Secretary of State